

## Data Sheet

### **GB-S Analog**

#### Magnetostrictive Linear Position Sensors

- High pressure resistant sensor rod
- High operating temperature up to +100 °C (+212 °F)
- Flat & compact – ideal for the valve market

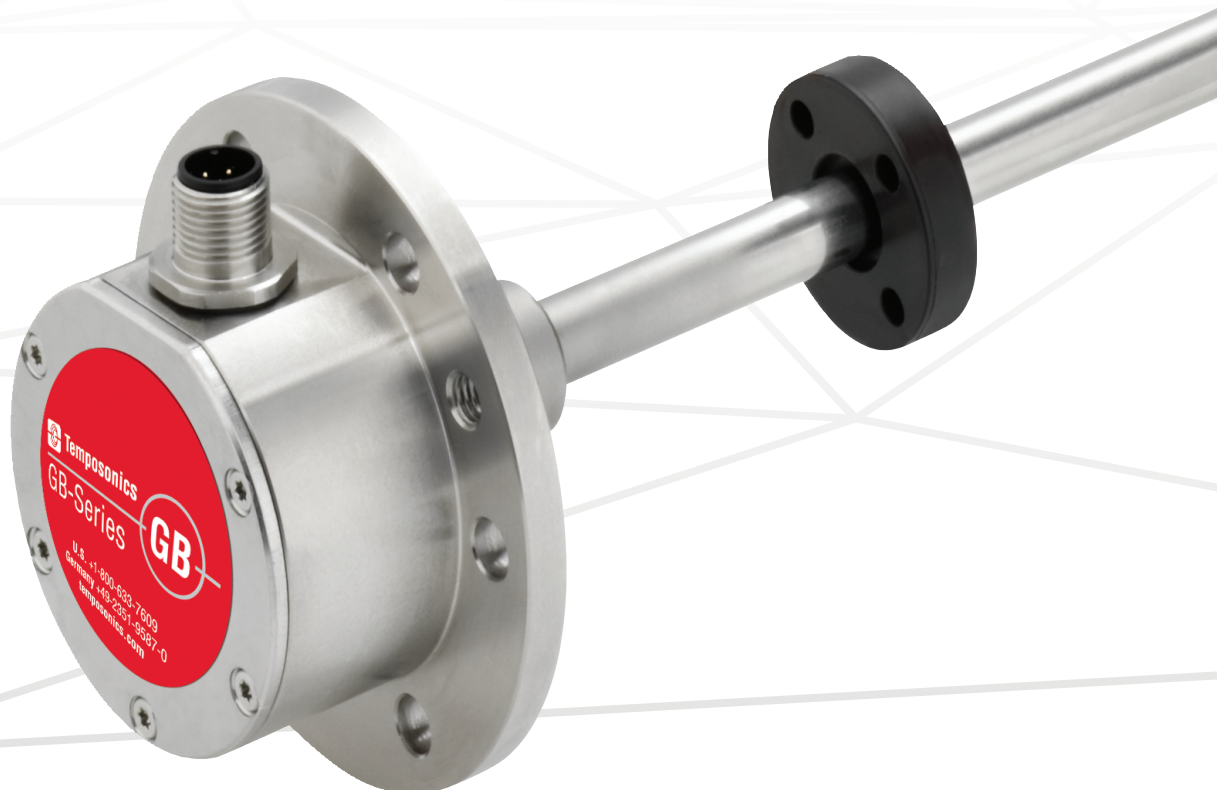

## MEASURING TECHNOLOGY

The absolute, linear position sensors provided by Temposonics rely on the company's proprietary magnetostrictive technology, which can determine position with a high level of precision and robustness. Each Temposonics position sensor consists of a ferromagnetic waveguide, a position magnet, a strain pulse converter and supporting electronics. The magnet, connected to the object in motion in the application, generates a magnetic field at its location on the waveguide. A short current pulse is applied to the waveguide. This creates a momentary radial magnetic field and torsional strain on the waveguide. The momentary interaction of the magnetic fields releases a torsional strain pulse that propagates the length of the waveguide. When the ultrasonic wave reaches the end of the waveguide it is converted into an electrical signal. Since the speed of the ultrasonic wave in the waveguide is precisely known, the time required to receive the return signal can be converted into a linear position measurement with both high accuracy and repeatability.

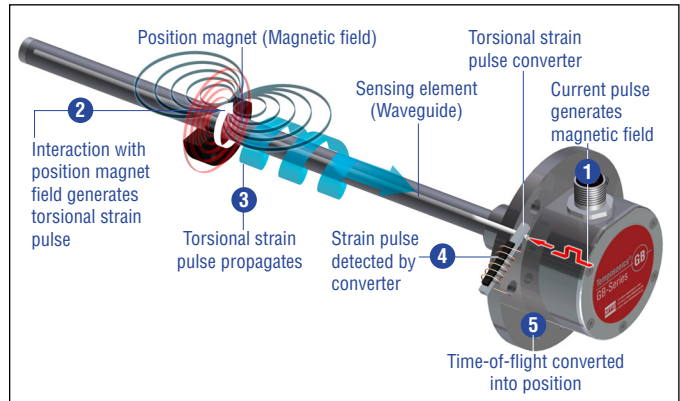

Fig. 1: Time-of-flight based magnetostrictive position sensing principle

## GB SENSOR

Robust, non-contact and wear free, the Temposonics linear position sensors provide best durability and accurate position measurement solutions in harsh industrial environments. The position measurement accuracy is tightly controlled by the quality of the waveguide which is manufactured by Temposonics. The position magnet is mounted on the moving machine part and travels non-contact over the sensor rod with the built-in waveguide.

Temposonics® GB is a rod-style sensor for installation into hydraulic cylinders, e.g. in power engineering. With its flat and compact sensor housing and side-mounted signal connection, the sensor is ideal for small spaces. Due to the pressure-resistant sensor rod and its high operating temperature the Temposonics® GB sensor is perfectly suitable for use in fluid technology. For improved signal quality the sensor automatically adapts to the strength of the magnet used in the application.

The set points, start and end position of the measurement, can be modified after installation of the Temposonics® GB sensor. Programming can be carried out using the standard connection cable.

## TECHNICAL DATA

Output				
Voltage	0...10 VDC and 10...0 VDC (minimum load controller: > 5 kΩ)			
Current	4(0)...20 mA or 20...4(0) mA (minimum / maximum load: 0 / 500 Ω)			
Programming	Programming of set points using optional accessories			
Measured value	Position			
Measurement parameters				
Resolution	16 bit (minimum 1 μm depending on stroke length) <sup>1</sup>			
Cycle time	Cycle time	0.5 ms	1.0 ms	2.0 ms
	Stroke length	≤ 1200 mm	≤ 2400 mm	> 2400 mm
Linearity <sup>2</sup>	≤ ±0.02 % F.S. (minimum ±60 μm) typical			
Repeatability	≤ ±0.005 % F.S. (minimum ±20 μm) typical			
Operating conditions				
Operating temperature	-40...+90 °C (-40...+194 °F); options: -40...+75 °C (+167 °F)/-40...+100 °C (+212 °F)			
Ingress protection	IP67 (correctly fitted); IP68 (for cable outlet)			
Shock test	100 g (single shock), IEC standard 60068-2-27			
Vibration test	15 g / 10...2000 Hz, IEC standard 60068-2-6 (excluding resonant frequencies)			
EMC test	Electromagnetic emission according to EN 61000-6-4			
	Electromagnetic immunity according to EN 61000-6-2			
	The sensor meets the requirements of the EU directives and is marked with <b>CE</b>			
Operating pressure	350 bar (5,076 psi), 700 bar (10,153 psi) peak (at 10 × 1 min), GB-J: 800 bar (11,603 psi)			
Magnet movement velocity	Any			
Design / Material				
Sensor electronics housing <sup>3</sup> with flange	GB-J / GB-K / GB-S: Stainless steel 1.4305 (AISI 303), GB-N: Stainless steel 1.4404 (AISI 316L)			
Sensor rod	GB-J: Stainless steel 1.4301 (AISI 304), GB-K / GB-S: Stainless steel 1.4306; 1.4307 (AISI 304L), GB-N: Stainless steel 1.4404 (AISI 316L)			
Stroke length	25...3250 mm (1...128 in.)			
Mechanical mounting				
Mounting position	Any			
Mounting instruction	Please consult the technical drawings and the operation manual (document number: <a href="#">551511</a> )			
Electrical connection				
Connection type	M12 male connector (5 pin); M16 male connector (6 pin); cable outlet			
Operating voltage	+24 VDC (-15 / +20 %)			
Ripple	≤ 0.28 V <sub>pp</sub>			
Current consumption	100 mA typical, dependent on stroke length			
Dielectric strength	500 VDC (DC ground to machine ground)			
Polarity protection	Up to -30 VDC			
Overvoltage protection	Up to 36 VDC			

1/ The internal digital value is transferred via a 16-bit D/A converter into a proportional, analog current or voltage signal

2/ With position magnet # 251 416-2

3/ For option **H** (-40...+100 °C / -40...+212 °F) an aluminum cover plate is used

# TECHNICAL DRAWING

## GB-N / GB-S, example: With M12 connector

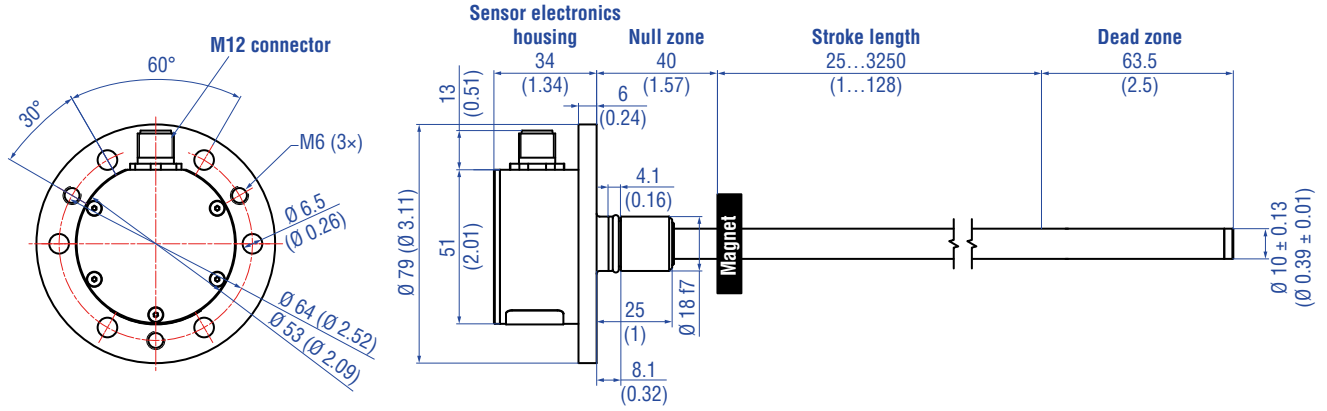

## GB-K, example: With M16 connector

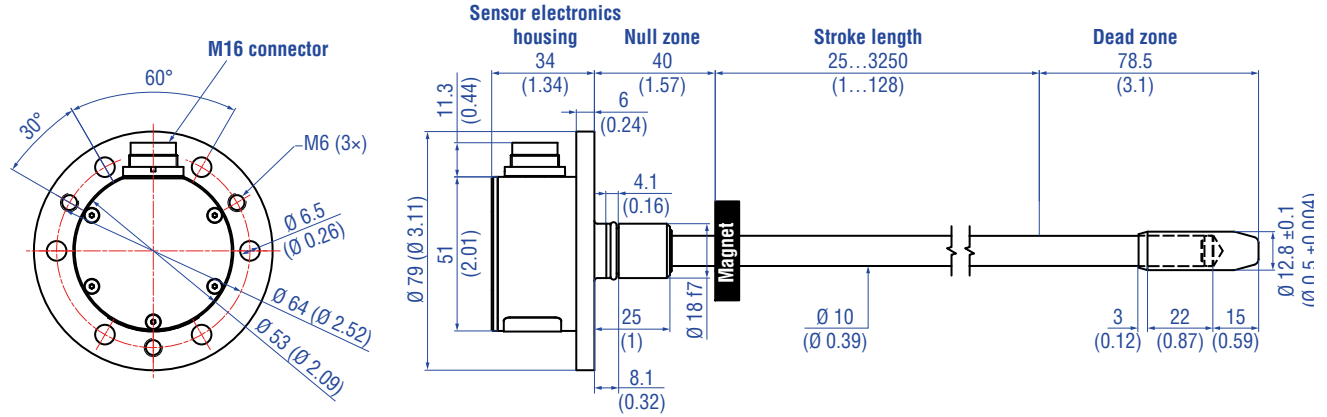

## GB-J, example: With cable outlet

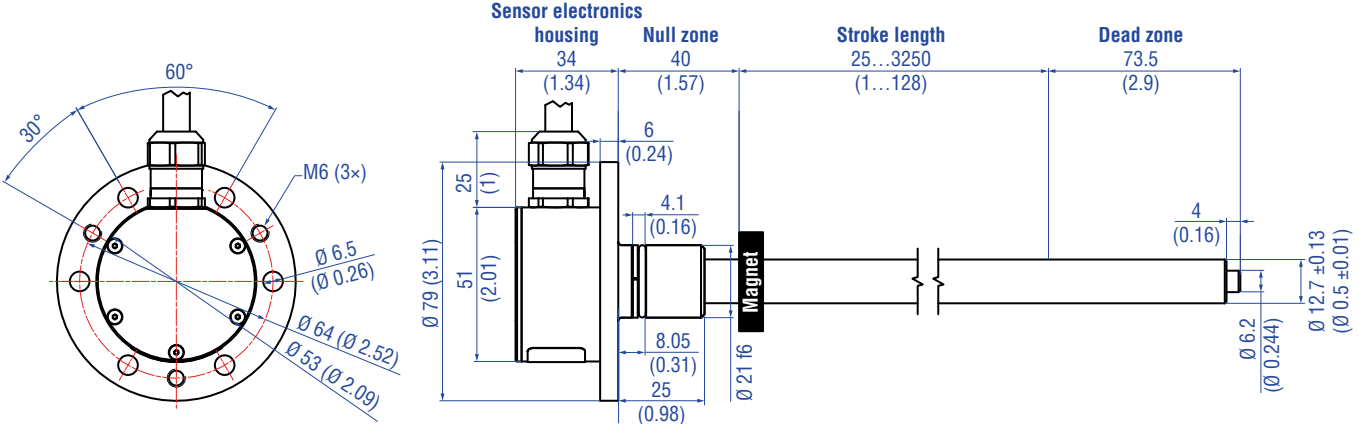

Controlling design dimensions are in millimeters and measurements in ( ) are in inches  
 Fig. 2: Temposonics® GB-N / GB-S / GB-K / GB-J with ring magnet

## CONNECTOR WIRING

D34 (for outputs: V0, A0, A1, A2, A3 in order code)			
Signal + power supply			
M12 male connector (A-coded)	Pin	Voltage	Current
 <p>View on sensor</p>	1	+24 VDC (-15 / +20 %)	+24 VDC (-15 / +20 %)
	2	0...10 VDC	4(0)...20 mA or 20... 4(0) mA
	3	DC Ground (0 V)	DC Ground (0 V)
	4	10...0 VDC	Not connected <sup>4</sup>
	5	DC Ground	DC Ground

Fig. 3: Connector wiring D34 (M12) for outputs V0, A0, A1, A2 and A3

D34 (for output: A4 in order code)		
Signal + power supply		
M12 male connector (A-coded)	Pin	Current
 <p>View on sensor</p>	1	+24 VDC (-15 / +20 %)
	2	4...20 mA <sup>5</sup>
	3	DC Ground (0 V)
	4	20...4 mA
	5	DC Ground

Fig. 6: Connector wiring D34 (M12) for output A4

D60 (for outputs: V0, A0, A1, A2, A3 in order code)			
Signal + power supply			
M16 male connector	Pin	Voltage	Current
 <p>View on sensor</p>	1	0...10 VDC	4(0)...20 mA or 20... 4(0) mA
	2	DC Ground	DC Ground
	3	10...0 VDC	Not connected <sup>4</sup>
	4	DC Ground	DC Ground
	5	+24 VDC (-15 / +20 %)	+24 VDC (-15 / +20 %)
	6	DC Ground (0 V)	DC Ground (0 V)

Fig. 4: Connector wiring D60 (M16) for outputs V0, A0, A1, A2 and A3

D60 (for output: A4 in order code)		
Signal + power supply		
M16 male connector	Pin	Current
 <p>View on sensor</p>	1	4...20 mA <sup>5</sup>
	2	DC Ground
	3	20...4 mA
	4	DC Ground
	5	+24 VDC (-15 / +20 %)
	6	DC Ground (0 V)

Fig. 7: Connector wiring D60 (M16) for output A4

HXX / TXX / VXX (for outputs: V0, A0, A1, A2, A3 in order code)			
Signal + power supply			
Cable	Color	Voltage	Current
	GY	0...10 VDC	4(0)...20 mA or 20... 4(0) mA
	PK	DC Ground	DC Ground
	YE	10...0 VDC	Not connected <sup>4</sup>
	GN	DC Ground	DC Ground
	BN	+24 VDC (-15 / +20 %)	+24 VDC (-15 / +20 %)
	WH	DC Ground (0 V)	DC Ground (0 V)

Fig. 5: Connector wiring cable outlet for outputs V0, A0, A1, A2 and A3

HXX / TXX / VXX (for output: A4 in order code)		
Signal + power supply		
Cable	Color	Current
	GY	4...20 mA <sup>5</sup>
	PK	DC Ground
	YE	20...4 mA
	GN	DC Ground
	BN	+24 VDC (-15 / +20 %)
	WH	DC Ground (0 V)

Fig. 8: Connector wiring cable outlet for output A4

4/ Connection necessary for programming with hand or cabinet programmer

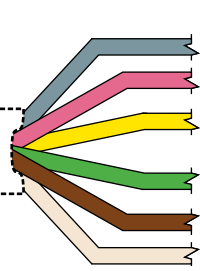
5/ Connect the first output (4...20 mA) at low-resistance, if you only use the second output (20...4 mA)

**FREQUENTLY ORDERED ACCESSORIES** – Additional options available in our [Accessories Guide](#)  [551444](#)

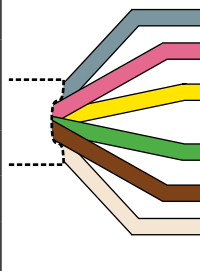
**Position magnets**

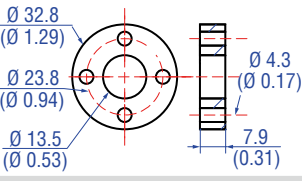
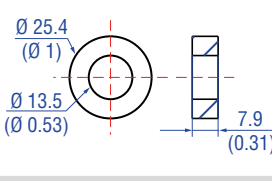
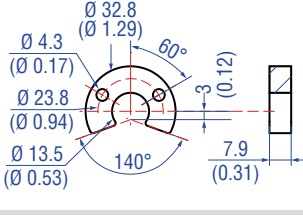
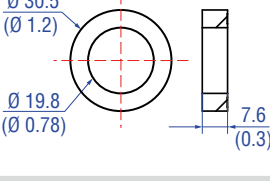
			
<p><b>Ring magnet OD33</b> Part no. 201 542-2</p> <p>Material: PA ferrite GF20 Weight: Approx. 14 g Surface pressure: Max. 40 N/mm<sup>2</sup> Fastening torque for M4 screws: 1 Nm Operating temperature: -40...+105 °C (-40...+221 °F)</p>	<p><b>Ring magnet OD25.4</b> Part no. 400 533</p> <p>Material: PA ferrite Weight: Approx. 10 g Surface pressure: Max. 40 N/mm<sup>2</sup> Operating temperature: -40...+105 °C (-40...+221 °F)</p>	<p><b>U-magnet OD33</b> Part no. 251 416-2</p> <p>Material: PA ferrite GF20 Weight: Approx. 11 g Surface pressure: Max. 40 N/mm<sup>2</sup> Fastening torque for M4 screws: 1 Nm Operating temperature: -40...+105 °C (-40...+221 °F)</p>	<p><b>Ring magnet</b> Part no. 402 316</p> <p>Material: PA ferrite coated Weight: Approx. 13 g Surface pressure: Max. 20 N/mm<sup>2</sup> Operating temperature: -40...+100 °C (-40...+212 °F)</p>

**Position magnet      O-rings      Back-up ring**

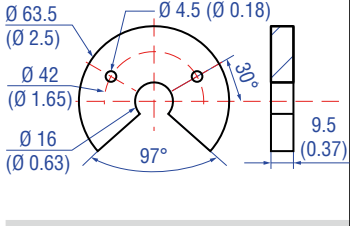
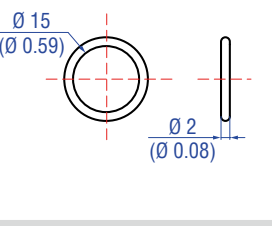
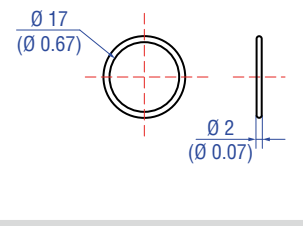
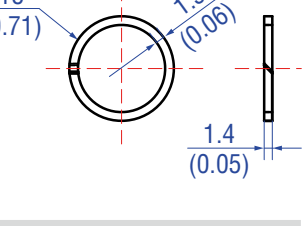
			
<p><b>U-magnet OD63.5</b> Part no. 201 553</p> <p>Material: PA 66-GF30, magnets compound-filled Weight: Approx. 26 g Surface pressure: 20 N/mm<sup>2</sup> Fastening torque for M4 screws: 1 Nm Operating temperature: -40...+75 °C (-40...+167 °F)</p>	<p><b>O-ring for pressure fit flange Ø 18 mm</b> Part no. 560 853</p> <p>Material: Fluoroelastomer Durometer: 75 Shore A Operating temperature: -40...+200 °C (-40...+392 °F)</p>	<p><b>O-ring for pressure fit flange Ø 21 mm</b> Part no. 561 438</p> <p>Material: FKM Durometer: 75 Shore A Operating temperature: -18...+200 °C (-0.4...+392 °F)</p>	<p><b>Back-up ring for pressure fit flange Ø 18 mm</b> Part no. 561 115</p> <p>Material: PTFE + 60 % bronze</p>

**Back-up ring      Optional installation hardware      Magnet spacer**

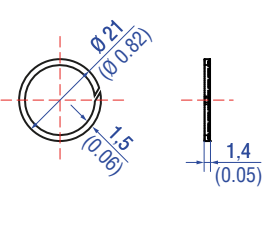
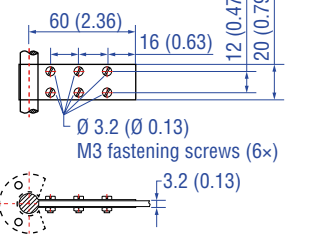
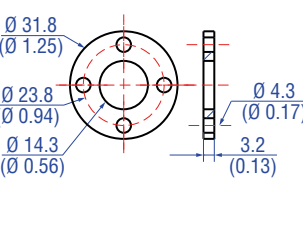

		
<p><b>Back-up ring for pressure fit flange Ø 21 mm</b> Part no. 561 439</p> <p>Material: PTFE</p>	<p><b>Fixing clip</b> Part no. 561 481</p> <p>Application: Used to secure sensor rods (Ø 10 mm (Ø 0.39 in.)) when using an U-magnet or block magnet Material: Brass, non-magnetic</p>	<p><b>Magnet spacer</b> Part no. 400 633</p> <p>Material: Aluminum Weight: Approx. 5 g Surface pressure: Max. 20 N/mm<sup>2</sup> Fastening torque for M4 screws: 1 Nm</p>

Controlling design dimensions are in millimeters and measurements in ( ) are in inches

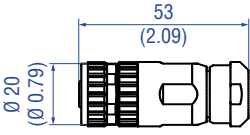
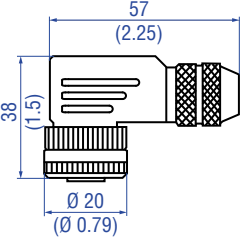
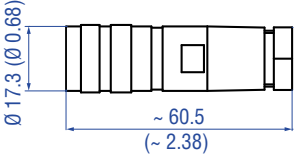
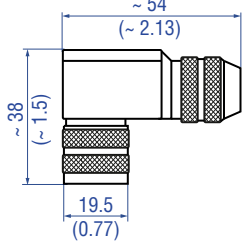
**Cable connectors<sup>9</sup>**

			
<p><b>M12 A-coded female connector (4 pin/5 pin), straight</b> Part no. 370 677</p>	<p><b>M12 A-coded female connector (5 pin), angled</b> Part no. 370 678</p>	<p><b>M16 female connector (6 pin), straight</b> Part no. 370 423</p>	<p><b>M16 female connector (6 pin), angled</b> Part no. 370 460</p>
<p>Material: GD-Zn, Ni Termination: Screw Contact insert: CuZn Cable Ø: 4...8 mm (0.16...0.31 in.) Wire: 1.5 mm<sup>2</sup> Operating temperature: -30...+85 °C (-22...+185 °F) Ingress protection: IP67 (correctly fitted) Fastening torque: 0.6 Nm</p>	<p>Material: GD-Zn, Ni Termination: Screw; max. 0.75 mm<sup>2</sup> Contact insert: CuZn Cable Ø: 5...8 mm (0.2...0.31 in.) Wire: 0.75 mm<sup>2</sup> (18 AWG) Operating temperature: -25...+85 °C (-13...+185 °F) Ingress protection: IP67 (correctly fitted) Fastening torque: 0.4 Nm</p>	<p>Material: Zinc nickel plated Termination: Solder Cable Ø: 6...8 mm (0.24...0.31 in.) Operating temperature: -40...+100 °C (-40...+212 °F) Ingress protection: IP65/IP67 (correctly fitted) Fastening torque: 0.6 Nm</p>	<p>Material: Zinc nickel plated Termination: Solder Cable Ø: 6...8 mm (0.24...0.31 in.) Wire: 0.75 mm<sup>2</sup> (20 AWG) Operating temperature: -40...+95 °C (-40...+203 °F) Ingress protection: IP67 (correctly fitted) Fastening torque: 0.6 Nm</p>

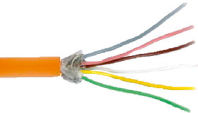
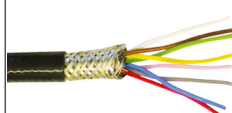

**Cables**

		
<p><b>PUR cable</b> Part no. 530 052</p>	<p><b>Teflon® cable</b> Part no. 530 112</p>	<p><b>Silicone cable</b> Part no. 530 113</p>
<p>Name of cable in order code: <b>H</b> Material: PUR jacket; orange Features: Twisted pair, shielded, highly flexible, halogen free, suitable for drag chains, mostly oil &amp; flame resistant Cable Ø: 6.4 mm (0.25 in.) Cross section: 3 × 2 × 0.25 mm<sup>2</sup> Bending radius: 5 × D (fixed installation) Operating temperature: -30...+80 °C (-22...+176 °F)</p>	<p>Name of cable in order code: <b>T</b> Material: Teflon® jacket; black Features: Twisted pair, shielded, flexible, high thermal resistance, mostly oil &amp; acid resistant Cable Ø: 7.6 mm (0.3 in.) Cross section: 4 × 2 × 0.25 mm<sup>2</sup> Bending radius: 8 – 10 × D (fixed installation) Operating temperature: -100...+180 °C (-148...+356 °F)</p>	<p>Name of cable in order code: <b>V</b> Material: Silicone jacket; red Features: Twisted pair, shielded, highly flexible, halogen free, high thermal resistance Cable Ø: 7.2 mm (0.28 in.) Cross section: 3 × 2 × 0.25 mm<sup>2</sup> Bending radius: 5 × D (fixed installation) Operating temperature: -50...+180 °C (-58...+356 °F)</p>

**Programming tool**

<p><b>Programming kit</b> Part no. 254 555</p>
<p>Kit includes: 1 × interface converter box 1 × power supply 1 × cable (60 cm) with M12 female connector (5 pin), straight – D-sub female connector (9 pin), straight 1 × cable (60 cm) with M16 female connector (6 pin), straight – D-sub female connector (9 pin), straight 1 × cable (60 cm) with 3 × terminal clamp – D-sub female connector (9 pin), straight 1 × USB cable</p>

**Programming tools**

	
<p><b>Hand programmer for analog output</b> Part no. 253 124</p>	<p><b>Cabinet programmer for analog output</b> Part no. 253 408</p>
<p>Easy teach-in-setups of stroke length and direction on desired zero / span positions. For sensors with 1 magnet.</p>	<p>Features snap-in mounting on standard DIN rail (35 mm). This programmer can be permanently mounted in a control cabinet and includes a program/run switch. For sensors with 1 magnet.</p>

Software is available at:  
[www.temposonics.com](http://www.temposonics.com)

Controlling design dimensions are in millimeters and measurements in ( ) are in inches

6/ Follow the manufacturer's mounting instructions

## ORDER CODE

1	2	3	4	5	6	7	8	9	10	11	12	13	14	15	16	
<b>G</b>	<b>B</b>										<b>1</b>				<b>C</b>	
<b>a</b>	<b>b</b>	<b>c</b>						<b>d</b>	<b>e</b>	<b>f</b>	<b>g</b>	<b>h</b>				

<b>a</b>	Sensor model
<b>G B</b>	Rod

<b>b</b>	Design
<b>J</b>	Housing material stainless steel 1.4305 (AISI 303), rod material stainless steel 1.4301 (AISI 304) Pressure fit flange Ø 21 mm, Ø 12.7 mm rod, 800 bar

<b>K</b>	Housing material stainless steel 1.4305 (AISI 303), rod material stainless steel 1.4306; 1.4307 (AISI 304L) Pressure fit flange Ø 18 mm, Ø 10 mm rod with bushing on rod end
----------	---

<b>N</b>	Housing material stainless steel 1.4404 (AISI 316L), rod material stainless steel 1.4404 (AISI 316L) <sup>7</sup> Pressure fit flange Ø 18 mm, Ø 10 mm rod
----------	---

<b>S</b>	Housing material stainless steel 1.4305 (AISI 303), rod material stainless steel 1.4306; 1.4307 (AISI 304L) Pressure fit flange Ø 18 mm, Ø 10 mm rod
----------	---

<b>c</b>	Stroke length
<b>X X X X M</b>	0025...3250 mm
<b>X X X X U</b>	001.0...128.0 in.

Standard stroke length (mm)*	Ordering steps
25... 500 mm	5 mm
500... 750 mm	10 mm
750...1000 mm	25 mm
1000...2500 mm	50 mm
2500...3250 mm	100 mm
Standard stroke length (in.)*	Ordering steps
1... 20 in.	0.2 in.
20... 30 in.	0.5 in.
30... 40 in.	1.0 in.
40...100 in.	2.0 in.
100...128 in.	4.0 in.

<b>d</b>	Connection type
<b>D 3 4</b>	M12 male connector (5 pin)
<b>D 6 0</b>	M16 male connector (6 pin)
<b>H X X</b>	PUR cable (part no. 530 052) H01...H10 (1...10 m) <sup>8</sup> H03...H33 (3...33 ft) <sup>8</sup> <b>CAUTION: Max. operating temperature -30...+80 °C (-22...+176 °F)!</b>

<b>d</b>	Connection type (continued)
<b>T X X</b>	Teflon® cable (part no. 530 112) T01...T10 (1...10 m) <sup>8</sup> T03...T33 (3...33 ft) <sup>8</sup>
<b>V X X</b>	Silicone cable (part no. 530 113) V01...V10 (1...10 m) <sup>8</sup> V03...V33 (3...33 ft) <sup>8</sup>

<b>e</b>	Operating voltage
<b>1</b>	+24 VDC (-15 / +20 %)

<b>f</b>	Output
<b>V 0</b>	0...10 VDC and 10...0 VDC
<b>A 0</b>	4...20 mA
<b>A 1</b>	20...4 mA
<b>A 2</b>	0...20 mA
<b>A 3</b>	20...0 mA
<b>A 4</b>	4...20 mA and 20...4 mA

<b>g</b>	Operating temperature
<b>H</b>	-40...+100 °C (-40...+212 °F)
<b>S</b>	-40...+90 °C (-40...+194 °F)
<b>L</b>	-40...+75 °C (-40...+167 °F)

<b>h</b>	Programming
<b>C</b>	Via cable

## DELIVERY



- Sensor
- O-ring
- Back-up ring

Accessories have to be ordered separately.

Manuals, Software & 3D Models available at:  
[www.temposonics.com](http://www.temposonics.com)

7/ The sensor in stainless steel 1.4404 (AISI 316L) is only available with following options: **S** (-40...+90 °C / -40...+194 °F)

\*/ Non standard stroke lengths are available; must be encoded in 5 mm / 0.1 in. increments

8/ Encode in meters if using metric stroke length. Encode in feet if using US customary stroke length



**UNITED STATES**  
**Temposonics, LLC**  
Americas & APAC Region  
3001 Sheldon Drive  
Cary, N.C. 27513  
Phone: +1 919 677-0100  
E-mail: info.us@temposonics.com

**GERMANY**  
**Temposonics**  
**GmbH & Co. KG**  
EMEA Region & India  
Auf dem Schüffel 9  
58513 Lüdenscheid  
Phone: +49 2351 9587-0  
E-mail: info.de@temposonics.com

**ITALY**  
Branch Office  
Phone: +39 030 988 3819  
E-mail: info.it@temposonics.com

**FRANCE**  
Branch Office  
Phone: +33 6 14 060 728  
E-mail: info.fr@temposonics.com

**UK**  
Branch Office  
Phone: +44 79 21 83 05 86  
E-mail: info.uk@temposonics.com

**SCANDINAVIA**  
Branch Office  
Phone: +46 70 29 91 281  
E-mail: info.sca@temposonics.com

**CHINA**  
Branch Office  
Phone: +86 21 2415 1000 / 2415 1001  
E-mail: info.cn@temposonics.com

**JAPAN**  
Branch Office  
Phone: +81 3 6416 1063  
E-mail: info.jp@temposonics.com

**Document Part Number:**  
551460 Revision E (EN) 06/2022

**UK  
CA**



**ISO 9001**  
CERTIFIED



**EAC** **cRU<sup>®</sup>** **US**

**temposonics.com**