

Data Sheet

GB-Series with pressure-fit flange Analog

Magnetostrictive Linear Position Sensors

- High pressure resistant sensor rod
- High operating temperature up to +100 °C (+212 °F)
- Flat & compact – ideal for the valve market

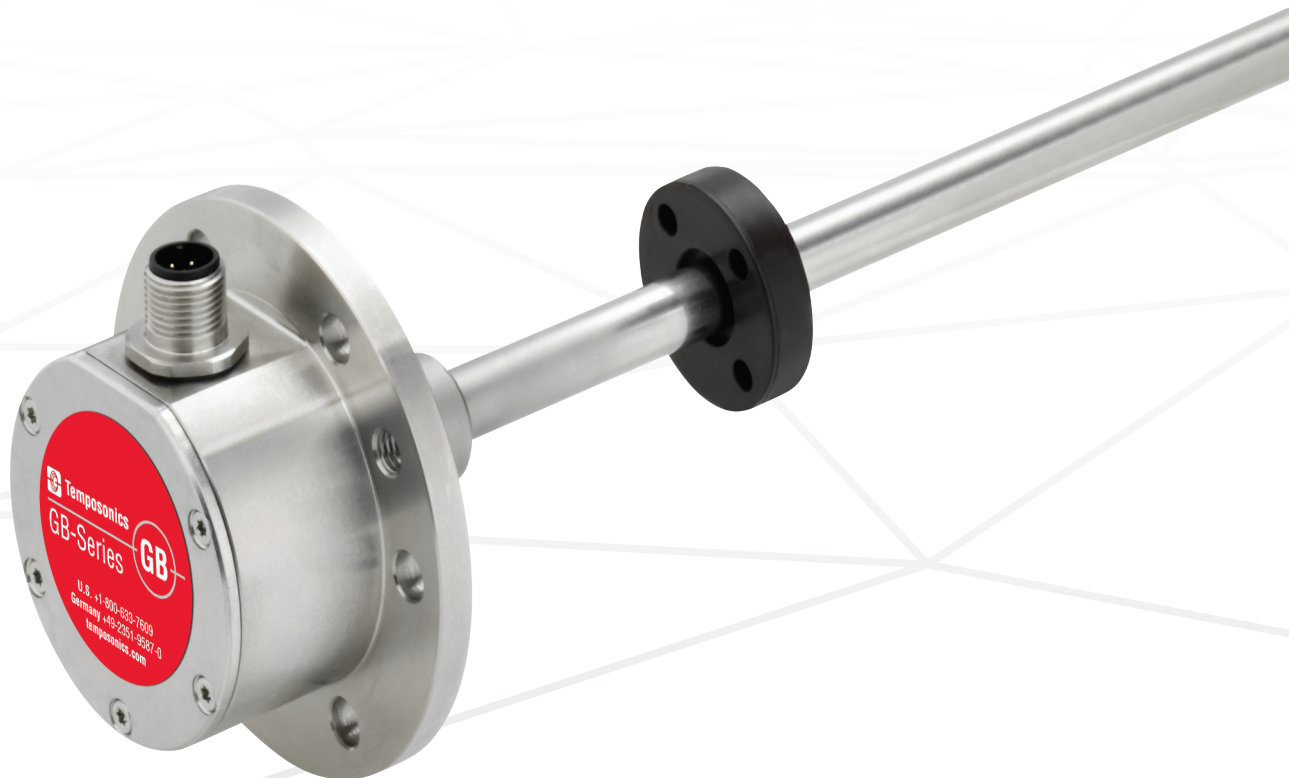

MEASURING TECHNOLOGY

The absolute, linear position sensors provided by Temposonics rely on the company's proprietary magnetostrictive technology, which can determine position with a high level of precision and robustness. Each Temposonics® position sensor consists of a ferromagnetic waveguide, a position magnet, a strain pulse converter and supporting electronics. The magnet, connected to the object in motion in the application, generates a magnetic field at its location on the waveguide. A short current pulse is applied to the waveguide. This creates a momentary radial magnetic field and torsional strain on the waveguide. The momentary interaction of the magnetic fields releases a torsional strain pulse that propagates the length of the waveguide. When the ultrasonic wave reaches the beginning of the waveguide it is converted into an electrical signal. Since the speed of the ultrasonic wave in the waveguide is precisely known, the time required to receive the return signal can be converted into a linear position measurement with both high accuracy and repeatability.

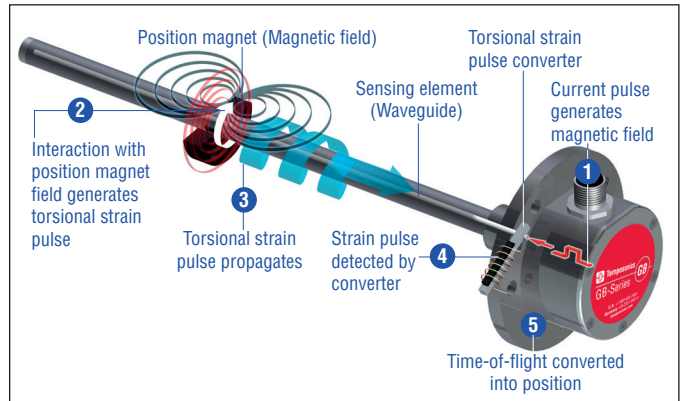

Fig. 1: Time-of-flight based magnetostrictive position sensing principle

GB SENSOR

Robust, non-contact and wear free, the Temposonics® linear position sensors provide best durability and accurate position measurement solutions in harsh industrial environments. The position measurement accuracy is tightly controlled by the quality of the waveguide which is manufactured by Temposonics. The position magnet is mounted on the moving machine part and travels non-contact over the sensor rod with the built-in waveguide.

Temposonics® GB is a rod-style sensor for installation into hydraulic cylinders, e.g. in power engineering. With its flat and compact sensor housing and side-mounted signal connection, the sensor is ideal for small spaces. Due to the pressure-resistant sensor rod and its high operating temperature the Temposonics® GB sensor is perfectly suitable for use in fluid technology. For improved signal quality the sensor automatically adapts to the strength of the magnet used in the application.

The set points, start and end position of the measurement, can be modified after installation of the Temposonics® GB sensor. Programming can be carried out using the standard connection cable.

TECHNICAL DATA

Output				
Voltage	0...10 VDC and 10...0 VDC (minimum load controller: > 5 kΩ)			
Current	4(0)...20 mA or 20...4(0) mA (minimum/maximum load: 0/500 Ω)			
Programming	Programming of set points using optional accessories			
Measured value	Position			
Measurement parameters				
Resolution	16 bit (minimum 1 μm depending on stroke length) ¹			
Cycle time	Cycle time	0.5 ms	1.0 ms	2.0 ms
	Stroke length	≤ 1200 mm	≤ 2400 mm	> 2400 mm
Linearity deviation ²	≤ ±0.02 % F.S. (minimum ±60 μm) typical			
Repeatability	≤ ±0.005 % F.S. (minimum ±20 μm) typical			
Operating conditions				
Operating temperature	-40...+90 °C (-40...+194 °F); options: -40...+75 °C (+167 °F)/-40...+100 °C (+212 °F)			
Ingress protection	IP67 (connectors correctly fitted); IP68 (for cable outlet)			
Shock test	100 g (single shock), IEC standard 60068-2-27			
Vibration test	15 g/10...2000 Hz, IEC standard 60068-2-6 (excluding resonant frequencies)			
EMC test	Electromagnetic emission according to EN 61000-6-4			
	Electromagnetic immunity according to EN 61000-6-2 The GB sensors fulfill the requirements of the EMC directives 2014/30/EU, UKSI 2016 No. 1091 and TR CU 020/2011			
Operating pressure	350 bar (5,076 psi), 700 bar (10,153 psi) peak (at 10 × 1 min), GB-J: 800 bar (11,603 psi)			
Magnet movement velocity	Any			
Design/Material				
Sensor electronics housing ³ with flange	GB-J/GB-K/GB-S:	Stainless steel 1.4305 (AISI 303),		
	GB-N:	Stainless steel 1.4404 (AISI 316L)		
Sensor rod	GB-J:	Stainless steel 1.4301 (AISI 304),		
	GB-K/GB-S:	Stainless steel 1.4306; 1.4307 (AISI 304L),		
	GB-N:	Stainless steel 1.4404 (AISI 316L)		
RoHS compliance	The used materials are compliant with the requirements of EU directive 2011/65/EU and EU regulation 2015/863 as well as UKSI 2022 No. 622 with amendments			
Stroke length	25...3250 mm (1...128 in.)			
Mechanical mounting				
Mounting position	Any			
Mounting instruction	Please consult the technical drawings and the operation manual (document number: 551511)			
Electrical connection				
Connection type	M12 male connector (5 pin) or M16 male connector (6 pin) or cable outlet			
Operating voltage	+24 VDC (-15/+20 %); The GB sensors must be power supplied via an external Class 2 power source in accordance with the UL approval			
Ripple	≤ 0.28 V _{pp}			
Current consumption	100 mA typical, dependent on stroke length			
Dielectric strength	500 VDC (DC ground to machine ground)			
Polarity protection	Up to -30 VDC			
Overvoltage protection	Up to 36 VDC			

1/ The internal digital value is transferred via a 16-bit D/A converter into a proportional, analog current or voltage signal.

2/ With position magnet # 251 416-2

3/ For option **H** (-40...+100 °C / -40...+212 °F) an aluminum cover plate is used

TECHNICAL DRAWING

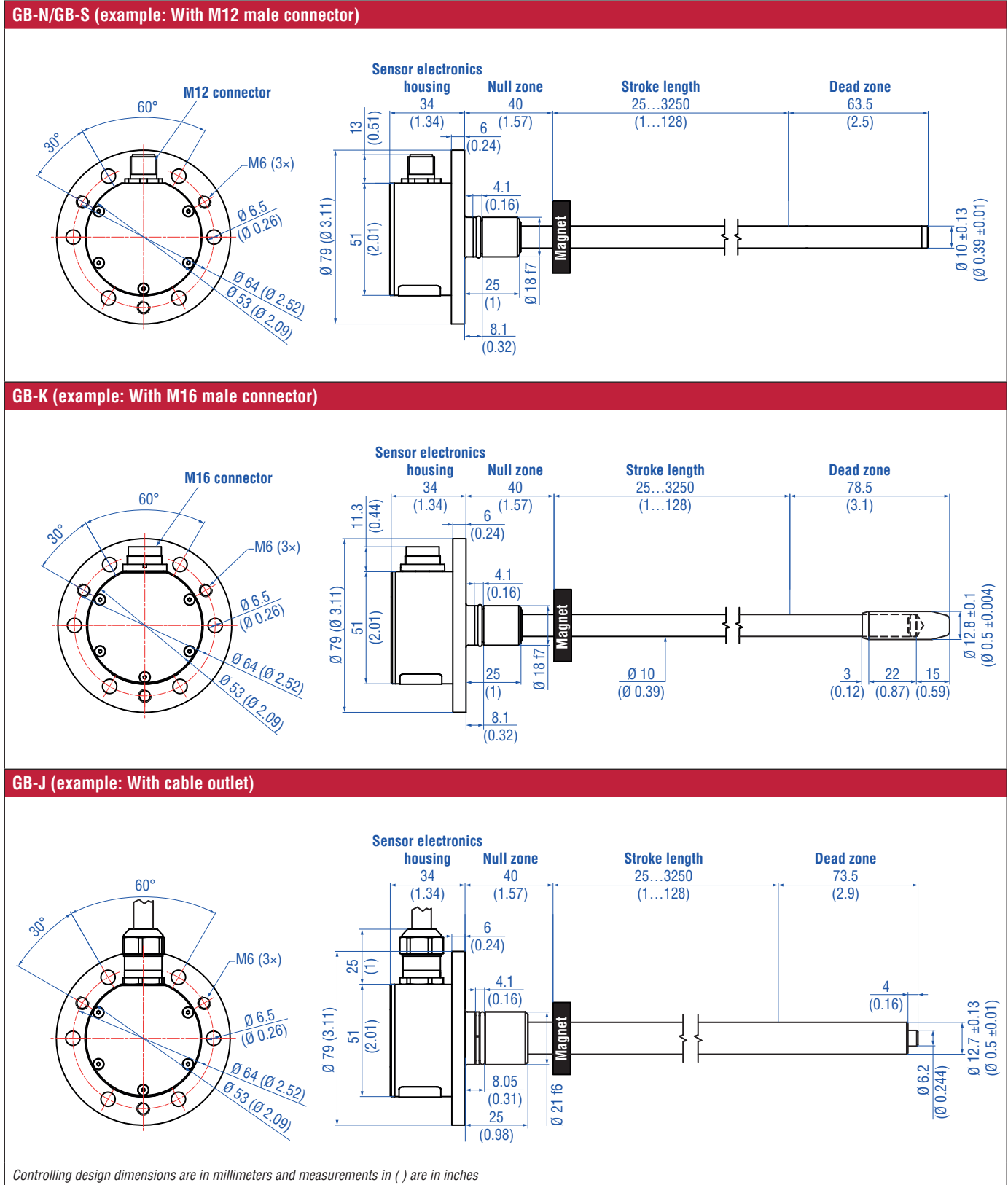



Fig. 2: Temposonics® GB-N / GB-S / GB-K / GB-J with ring magnet

CONNECTOR WIRING

D34 (for outputs: V0, A4 in order code)				
Signal + power supply				
M12 male connector (A-coded)	Output	Pin	Voltage	Current
 <p>View on sensor</p>	1	1	+24 VDC (-15 /+20 %)	+24 VDC (-15 /+20 %)
		2	0...10 VDC	4...20 mA *
		3	DC Ground (0 V)	DC Ground (0 V)
	2	4	10...0 VDC	20...4 mA
		5	Signal Ground for Output 1/2	Signal Ground for Output 1/2

*/ Connect the first output to ground, if you only use the second output.

Fig. 3: Connector wiring D34 (M12) for outputs V0, A4

D34 (for outputs: A0, A1, A2, A3 in order code)		
Signal + power supply		
M12 male connector (A-coded)	Pin	Current
 <p>View on sensor</p>	1	+24 VDC (-15 /+20 %)
	2	4(0)...20 mA or 20... 4(0) mA
	3	DC Ground (0 V)
	4	Do not connect *
	5	Signal Ground

*/ Connection necessary for programming with hand or cabinet programmer.

Fig. 4: Connector wiring D34 (M12) for outputs A0, A1, A2 and A3

D60 (for outputs: V0, A4 in order code)				
Signal + power supply				
M16 male connector	Output	Pin	Voltage	Current
 <p>View on sensor</p>	1	1	0...10 VDC	4...20 mA *
		2	Signal Ground	Signal Ground
	2	3	10...0 VDC	20...4 mA
		4	Signal Ground	Signal Ground
		5	+24 VDC (-15 /+20 %)	+24 VDC (-15 /+20 %)
		6	DC Ground (0 V)	DC Ground (0 V)

*/ Connect the first output to ground, if you only use the second output.

Fig. 5: Connector wiring D60 (M16) for outputs V0, A4

D60 (for outputs: A0, A1, A2, A3 in order code)		
Signal + power supply		
M16 male connector	Pin	Current
 <p>View on sensor</p>	1	4(0)...20 mA or 20... 4(0) mA
	2	Signal Ground
	3	Do not connect *
	4	DC Ground
	5	+24 VDC (-15 /+20 %)
	6	DC Ground (0 V)

*/ Connection necessary for programming with hand or cabinet programmer.

Fig. 6: Connector wiring D60 (M16) for outputs A0, A1, A2 and A3

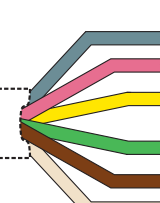
HXX/TXX/VXX (for outputs: V0, A4 in order code)				
Signal + power supply				
Cable	Output	Color	Voltage	Current
	1	GY	0...10 VDC	4...20 mA *
		PK	Signal Ground	Signal Ground
	2	YE	10...0 VDC	20...4 mA
		GN	Signal Ground	Signal Ground
		BN	+24 VDC (-15 /+20 %)	+24 VDC (-15 /+20 %)
		WH	DC Ground (0 V)	DC Ground (0 V)

*/ Connect the first output to DC Ground (0 V), if you only use the second output.

Fig. 7: Connector wiring cable outlet for outputs V0, A4

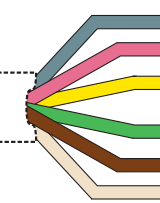
HXX/TXX/VXX (for outputs: A0, A1, A2, A3 in order code)		
Signal + power supply		
Cable	Color	Current
	GY	4(0)...20 mA or 20... 4(0) mA
	PK	Signal Ground
	YE	Do not connect *
	GN	DC Ground
	BN	+24 VDC (-15 /+20 %)
	WH	DC Ground (0 V)

*/ Connection necessary for programming with hand or cabinet programmer.

Fig. 8: Connector wiring cable outlet for outputs A0, A1, A2 and A3

FREQUENTLY ORDERED ACCESSORIES – Additional options available in our [Accessories Guide](#) 551444

Position magnets

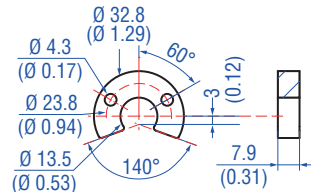
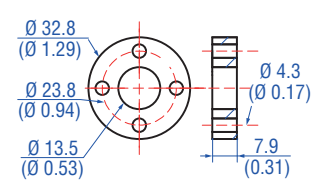
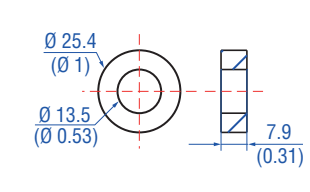
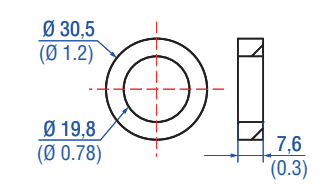
			
<p>U-magnet OD33 Part no. 251 416-2</p> <p>Material: PA ferrite GF20 Weight: Approx. 11 g Surface pressure: Max. 40 N/mm² Fastening torque for M4 screws: 1 Nm Operating temperature: -40...+120 °C (-40...+248 °F)</p>	<p>Ring magnet OD33 Part no. 201 542-2</p> <p>Material: PA ferrite GF20 Weight: Approx. 14 g Surface pressure: Max. 40 N/mm² Fastening torque for M4 screws: 1 Nm Operating temperature: -40...+120 °C (-40...+248 °F)</p>	<p>Ring magnet OD25.4 Part no. 400 533</p> <p>Material: PA ferrite Weight: Approx. 10 g Surface pressure: Max. 40 N/mm² Operating temperature: -40...+120 °C (-40...+248 °F)</p>	<p>Ring magnet Part no. 402 316</p> <p>Material: PA ferrite coated Weight: Approx. 13 g Surface pressure: Max. 20 N/mm² Operating temperature: -40...+100 °C (-40...+212 °F)</p>

Position magnet O-rings Back-up ring

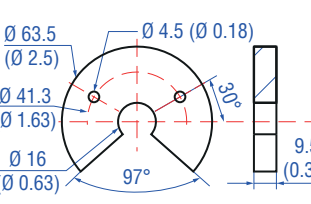
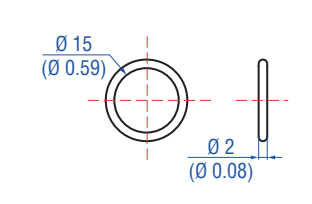
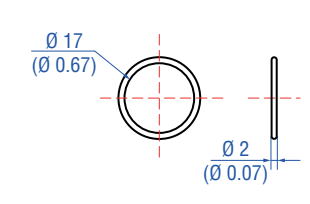
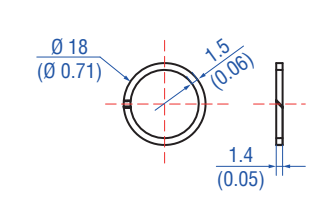
			
<p>U-magnet OD63.5 Part no. 201 553</p> <p>Material: PA 66-GF30, magnets compound-filled Weight: Approx. 26 g Surface pressure: 20 N/mm² Fastening torque for M4 screws: 1 Nm Operating temperature: -40...+75 °C (-40...+167 °F)</p>	<p>O-ring for pressure fit flange Ø 18 mm Part no. 560 853</p> <p>Material: Fluoroelastomer Durometer: 75 Shore A Operating temperature: -40...+200 °C (-40...+392 °F)</p>	<p>O-ring for pressure fit flange Ø 21 mm Part no. 561 438</p> <p>Material: FKM Durometer: 75 Shore A Operating temperature: -18...+200 °C (-0.4...+392 °F)</p>	<p>Back-up ring for pressure fit flange Ø 18 mm Part no. 561 115</p> <p>Material: PTFE + 60 % bronze</p>

Back-up ring Mounting accessories

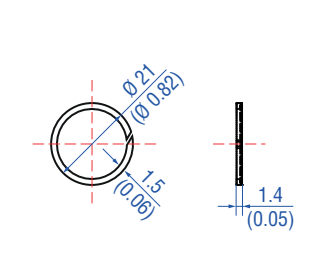
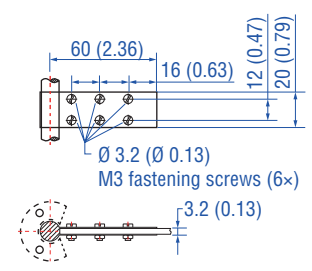
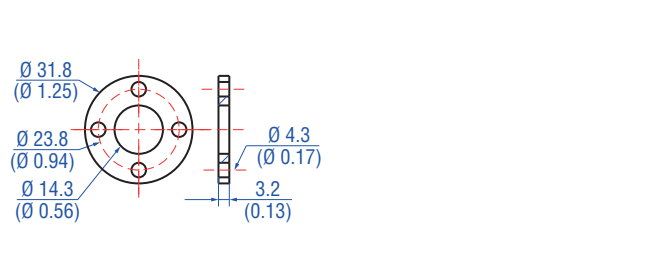

		
<p>Back-up ring for pressure fit flange Ø 21 mm Part no. 561 439</p> <p>Material: PTFE</p>	<p>Fixing clip Part no. 561 481</p> <p>Application: Used to secure sensor rods (Ø 10 mm (Ø 0.39 in.)) when using an U-magnet or block magnet Material: Brass, non-magnetic</p>	<p>Magnet spacer Part no. 400 633</p> <p>Material: Aluminum Weight: Approx. 5 g Surface pressure: Max. 20 N/mm² Fastening torque for M4 screws: 1 Nm</p>

Controlling design dimensions are in millimeters and measurements in () are in inches

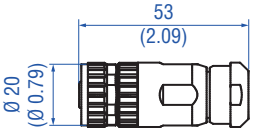
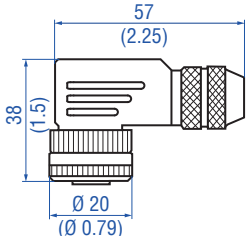
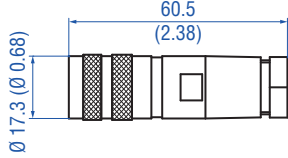
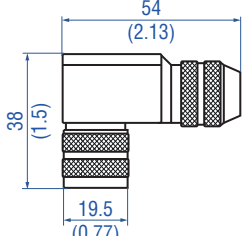
Cable connectors*

			
<p>M12 A-coded female connector (4 pin/5 pin), straight Part no. 370 677</p>	<p>M12 A-coded female connector (5 pin), angled Part no. 370 678</p>	<p>M16 female connector (6 pin), straight Part no. 370 423</p>	<p>M16 female connector (6 pin), angled Part no. 370 460</p>
<p>Material: GD-Zn, Ni Termination: Screw Contact insert: CuZn Cable Ø: 4...8 mm (0.16...0.31 in.) Wire: Max. 1.5 mm² (16 AWG) Operating temperature: -30...+85 °C (-22...+185 °F) Ingress protection: IP67 (correctly fitted) Fastening torque: 0.6 Nm</p>	<p>Material: GD-Zn, Ni Termination: Screw Contact insert: CuZn Cable Ø: 5...8 mm (0.2...0.31 in.) Wire: Max 0.75 mm² (18 AWG) Operating temperature: -25...+85 °C (-13...+185 °F) Ingress protection: IP67 (correctly fitted) Fastening torque: 0.4 Nm</p>	<p>Material: Zinc nickel plated Termination: Solder Cable Ø: 6...8 mm (0.24...0.31 in.) Operating temperature: -40...+100 °C (-40...+212 °F) Ingress protection: IP65/IP67 (correctly fitted) Fastening torque: 0.6 Nm</p>	<p>Material: Zinc nickel plated Termination: Solder Cable Ø: 6...8 mm (0.24...0.31 in.) Wire: 0.75 mm² (20 AWG) Operating temperature: -40...+95 °C (-40...+203 °F) Ingress protection: IP67 (correctly fitted) Fastening torque: 0.6 Nm</p>

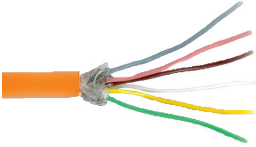
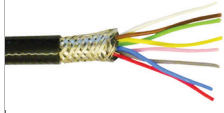
Cables

		
<p>PUR cable Part no. 530 052</p> <p>Material: PUR jacket; orange Features: Twisted pair, shielded, highly flexible, halogen free, suitable for drag chains, mostly oil & flame resistant Cable Ø: 6.4 mm (0.25 in.) Cross section: 3 × 2 × 0.19 mm² Bending radius: 5 × D (fixed installation) Operating temperature: -20...+80 °C (-4...+176 °F)</p>	<p>FEP cable Part no. 530 112</p> <p>Material: FEP jacket; black Features: Twisted pair, shielded, flexible, high thermal resistance, mostly oil & acid resistant Cable Ø: 7.6 mm (0.3 in.) Cross section: 4 × 2 × 0.25 mm² Bending radius: 8 – 10 × D (fixed installation) Operating temperature: -100...+180 °C (-148...+356 °F)</p>	<p>Silicone cable Part no. 530 113</p> <p>Material: Silicone jacket; red Features: Twisted pair, shielded, highly flexible, halogen free, high thermal resistance Cable Ø: 7.2 mm (0.28 in.) Cross section: 3 × 2 × 0.25 mm² Bending radius: 5 × D (fixed installation) Operating temperature: -50...+180 °C (-58...+356 °F)</p>

*/ Follow the manufacturer's mounting instructions
Color of connectors and cable jacket may change. Color codes for the individual wires and technical properties remain unchanged.
Controlling design dimensions are in millimeters and measurements in () are in inches

Programming tools



Hand programmer for analog output
Part no. 253 124

Easy teach-in-setups of stroke length and direction on desired zero/span positions. For sensors with 1 magnet.

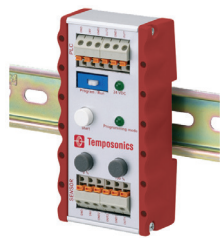

Cabinet programmer for analog output
Part no. 253 408

Features snap-in mounting on standard DIN rail (35 mm). This programmer can be permanently mounted in a control cabinet and includes a program/run switch. For sensors with 1 magnet.



Programming kit
Part no. 254 555

Kit includes:
1 × interface converter box
1 × power supply
1 × cable (60 cm) with M12 female connector (5 pin), straight – D-sub female connector (9 pin), straight
1 × cable (60 cm) with M16 female connector (6 pin), straight – D-sub female connector (9 pin), straight
1 × cable (60 cm) with 3 × terminal clamp – D-sub female connector (9 pin), straight
1 × USB cable

Software is available at:
www.temposonics.com

ORDER CODE

1	2	3	4	5	6	7	8	9	10	11	12	13	14	15	16
G	B										1				C
a	b	c						d	e	f	g	h			

a	Sensor model
G B	Rod

b	Design
J	Housing material stainless steel 1.4305 (AISI 303), rod material stainless steel 1.4301 (AISI 304) Pressure fit flange Ø 21 mm, Ø 12.7 mm rod, 800 bar
K	Housing material stainless steel 1.4305 (AISI 303), rod material stainless steel 1.4306; 1.4307 (AISI 304L) Pressure fit flange Ø 18 mm, Ø 10 mm rod with bushing on rod end
N	Housing material stainless steel 1.4404 (AISI 316L), rod material stainless steel 1.4404 (AISI 316L) Pressure fit flange Ø 18 mm, Ø 10 mm rod This design option is only available with following option: s (-40...+90 °C/-40...+194 °F)
S	Housing material stainless steel 1.4305 (AISI 303), rod material stainless steel 1.4306; 1.4307 (AISI 304L) Pressure fit flange Ø 18 mm, Ø 10 mm rod

c	Stroke length
X X X X M	0025...3250 mm
X X X X U	001.0...128.0 in.
Standard stroke length (mm)	Ordering steps
25... 500 mm	5 mm
500... 750 mm	10 mm
750...1000 mm	25 mm
1000...2500 mm	50 mm
2500...3250 mm	100 mm
Standard stroke length (in.)	Ordering steps
1... 20 in.	0.2 in.
20... 30 in.	0.5 in.
30... 40 in.	1.0 in.
40...100 in.	2.0 in.
100...128 in.	4.0 in.

d	Connection type
Connector	
D 3 4	M12 male connector (5 pin)
D 6 0	M16 male connector (6 pin)
Cable outlet	
H X X	XX m/ft. PUR cable (part no. 530 052) H01...H30 (1...30 m/3...99 ft.) (Note the temperature range of the cable!) See "Frequently ordered accessories" for cable specifications
T X X	XX m/ft. FEP cable (part no. 530 112) T01...T30 (1...30 m/3...99 ft.) See "Frequently ordered accessories" for cable specifications
V X X	XX m/ft. Silicone cable (part no. 530 113) V01...V30 (1...30 m/3...99 ft.) See "Frequently ordered accessories" for cable specifications
Encode in meters if using metric stroke length. Encode in feet if using US customary stroke length.	

e	Operation voltage
1	+24 VDC (-15/+20 %)

f	Output
V 0	0...10 VDC and 10...0 VDC
A 0	4...20 mA
A 1	20...4 mA
A 2	0...20 mA
A 3	20...0 mA
A 4	4...20 mA and 20...4 mA

g	Operating temperature
H	-40...+100 °C (-40...+212 °F)
S	-40...+90 °C (-40...+194 °F)
L	-40...+75 °C (-40...+167 °F)

h	Programming
C	Via cable

DELIVERY



- Sensor
- O-ring
- Back-up ring

Accessories have to be ordered separately.

Manuals, Software & 3D Models available at:
www.temposonics.com

USA
Temposonics, LLC
Amerika & APAC Region
3001 Sheldon Drive
Cary, N.C. 27513
Telefon: +1 919 677-0100
E-Mail: info.us@temposonics.com

DEUTSCHLAND
**Temposonics
GmbH & Co. KG**
EMEA Region & India
Auf dem Schüffel 9
58513 Lüdenscheid
Telefon: +49 2351 9587-0
E-Mail: info.de@temposonics.com

ITALIEN
Zweigstelle
Telefon: +39 030 988 3819
E-Mail: info.it@temposonics.com

FRANKREICH
Zweigstelle
Telefon: +33 6 14 060 728
E-Mail: info.fr@temposonics.com

UK
Zweigstelle
Telefon: +44 79 21 83 05 86
E-Mail: info.uk@temposonics.com

SKANDINAVIEN
Zweigstelle
Telefon: +46 70 29 91 281
E-Mail: info.sca@temposonics.com

CHINA
Zweigstelle
Telefon: +86 21 3405 7850
E-Mail: info.cn@temposonics.com

JAPAN
Zweigstelle
Telefon: +81 3 6416 1063
E-Mail: info.jp@temposonics.com

Document Part Number:
551460 Revision F (DE) 03/2026



temposonics.com