

Data Sheet

Level Plus[®] Model LLH

Magnetostrictive Liquid Level Transmitters with Temposonics[®] Technology

- Compact Sanitary Level Measurement
- Inherent Accuracy ± 0.5 mm
- No Scheduled Maintenance or Recalibration

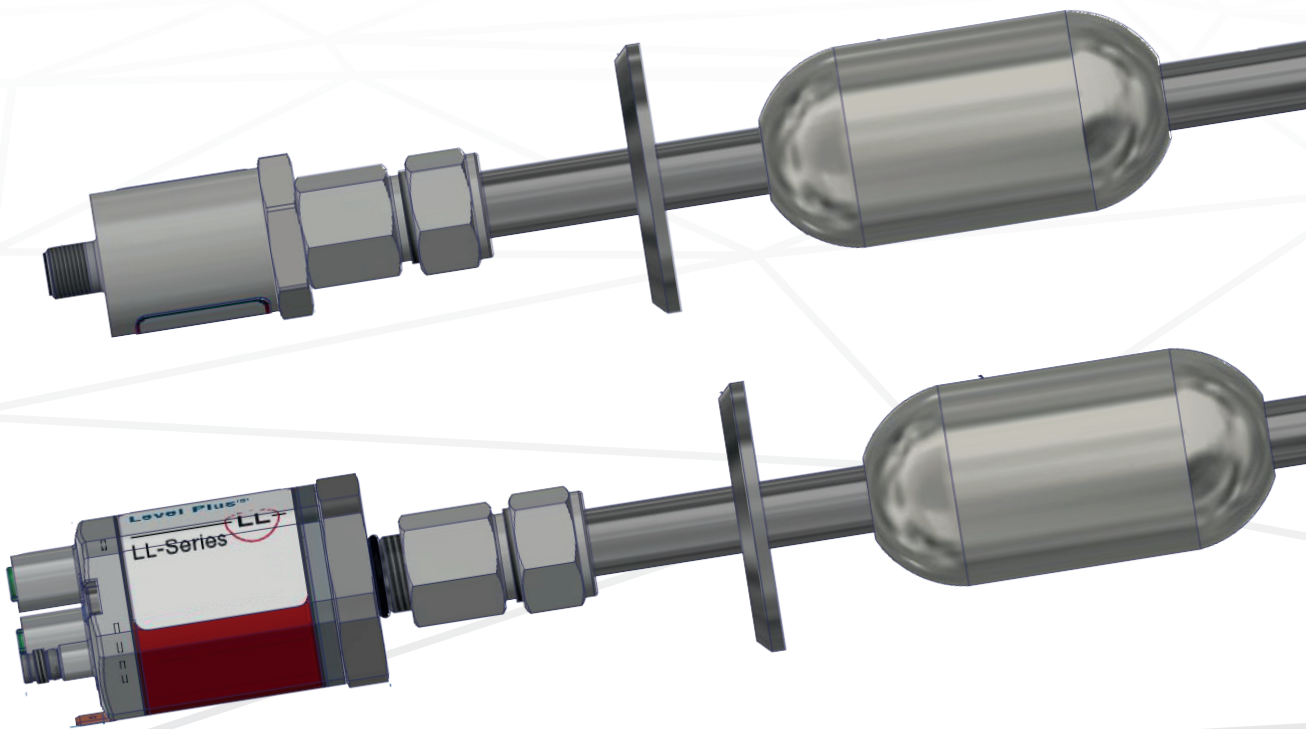

MEASURING TECHNOLOGY

The absolute, linear position sensors provided by Temposonics rely on the company's proprietary Temposonics® magnetostrictive technology, which can determine position with a high level of precision and robustness. Each Temposonics® position sensor consists of a ferromagnetic waveguide, a position magnet, a strain pulse converter and supporting electronics. The magnet, connected to the object in motion in the application, generates a magnetic field at its location on the waveguide. A short current pulse is applied to the waveguide. This creates a momentary radial magnetic field and torsional strain on the waveguide. The momentary interaction of the magnetic fields releases a torsional strain pulse that propagates the length of the waveguide. When the ultrasonic wave reaches the end of the waveguide it is converted into an electrical signal. Since the speed of the ultrasonic wave in the waveguide is precisely known, the time required to receive the return signal can be converted into a linear position measurement with both high accuracy and repeatability.

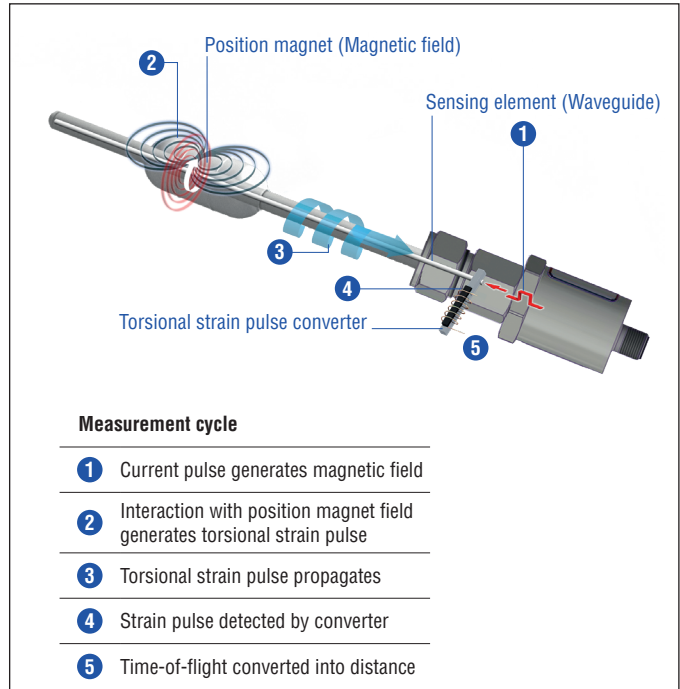

Fig. 1: Time-of-flight based magnetostrictive position sensing principle

LLH LEVEL TRANSMITTER

The Level Plus LLH satisfies the demand for an accurate and robust liquid level transmitter for sanitary/hygienic applications. The LLH can provide product level and/or interface level in a compact mechanical design. There is no requirement for scheduled maintenance or recalibration for the expected 10 year life of the sensor. **Set it and Forget it.**

The LLH liquid level transmitter can be mounted on most tanks offering NPT and Tri-Clamp connections from ¾ to 6 inches. The LLH also offers a variety of outputs including Analog, CANbus, SSI, IO-Link, POWERLINK, PROFINET, EtherNet/IP™ and EtherCAT®. Included in the model number is the selection of the float and cable. The single model offers everything needed for level measurement in a variety of sanitary applications.

Features:

- Sanitary Finish Ra 25 uin (0.64 µm)
- Product and Interface Level
- No scheduled maintenance or recalibration
- Inherent Accuracy ± 0.5 mm
- IP69K
- 100 g Shock/15 g Vibration

Applications:

- Bottle Filling Machines
- CIP Tanks
- Skids
- Balance Tanks
- Fermentation Tanks
- Dispensing

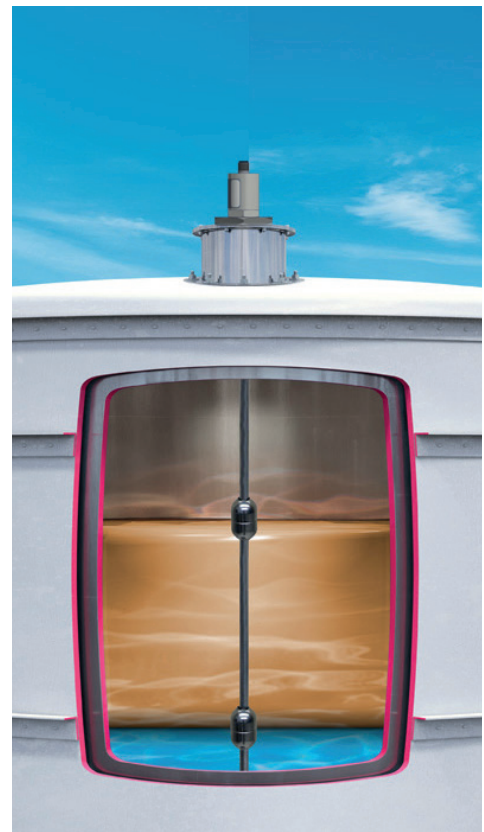

Fig. 2: Example of product and interface level measurement

TECHNICAL DATA

Output Options	
Voltage	0...10 VDC or 10...0 VDC, 0...10 VDC and 10...0 VDC (controller input resistance $R_L > 5 \text{ k}\Omega$)
Current	4...20 mA or 20...4 mA (minimum/maximum load: 0/500 Ω)
SSI (Synchronous Serial Interface)	Binary or Gray, 24 or 25 bit
CANbus	CANopen: CIA standard DS 301 V3.0/encoder profile DS 406 V3.1, CAN System ISO-11898
IO-Link	V1.1, 32 bit signed, COM3 (230.4 kBaud)
EtherCAT®	100 Base-Tx, Fast Ethernet, 100 Mbits/s max
POWERLINK	Ethernet POWERLINK V2
EtherNet/IP™	Encoder CIP device profile with CIP Sync and DLR capabilities, 100 Mbits/s max
PROFINET	Profinet RT, Profinet IRT version 2.3, MTS Profile and Encoder Profile 4.1, 100 Mbits/s max
Measured value	Product Level and/or Interface Level
Measurement parameters	
Resolution	0.1 mm or greater
Inherent accuracy	$\pm 0.5 \text{ mm}$
Repeatability	$\leq \pm 0.005 \text{ \% F.S.}$ (minimum $\pm 20 \text{ }\mu\text{m}$)
Operating conditions	
Operating temperature	$-40...+75 \text{ }^\circ\text{C}$ ($-40...+167 \text{ }^\circ\text{F}$)
Humidity	90 % relative humidity, no condensation
Ingress protection ¹	IP67/IP69K (select outputs only, see manual 552103) (correctly fitted)
Shock test	100 g (single shock) IEC standard 60068-2-27
Vibration test	15 g/10...2000 Hz IEC standard 60068-2-6 (resonance frequencies excluded)
EMC test	Electromagnetic emission according to EN 61000-6-3 Electromagnetic immunity according to EN 61000-6-2 The sensor meets the requirements of the EU directives and is marked with CE
Design/Material	
Sensor electronics housing/Flange	Stainless steel 1.4305 (AISI 303); option: Stainless steel 1.4404 (AISI 316L)
Wetted parts	Stainless steel 1.4404 (AISI 316L) Ra 25 uin. (Ra 0.625um)
Order Length	136 to 2525 mm (5.35 to 99.4 in)
Operating pressure	5/8" O.D. 69 bar (1000 psi)
Mounting	
Rigid Pipe	NPT (3/4", 1", 1.5", 2", 2.5", 3", 4"), ANSI RF Flange (2", 3", 4", 5", 6") (150#, 300#, 600#)
Electrical connection	
Connection type	M12 male connector (for pin see page 5 and page 6)
Operating voltage	+24 VDC ($-15/+20 \text{ \%}$); UL recognition requires an approved power supply with energy limitation (UL 61010-1), or Class 2 rating according to the National Electrical Code (USA)/ Canadian Electrical Code
Ripple	$\leq 0.28 \text{ V}_{pp}$
Current consumption	Analog: 50...140 mA, SSI, CANbus & IO-Link: 60 mA
Dielectric strength	500 VDC (DC ground to machine ground)
Polarity protection	Up to -30 VDC
Overvoltage protection	Up to 36 VDC

¹/ The IP rating is not part of the UL recognition

TECHNICAL DRAWING

LLH - E-Series

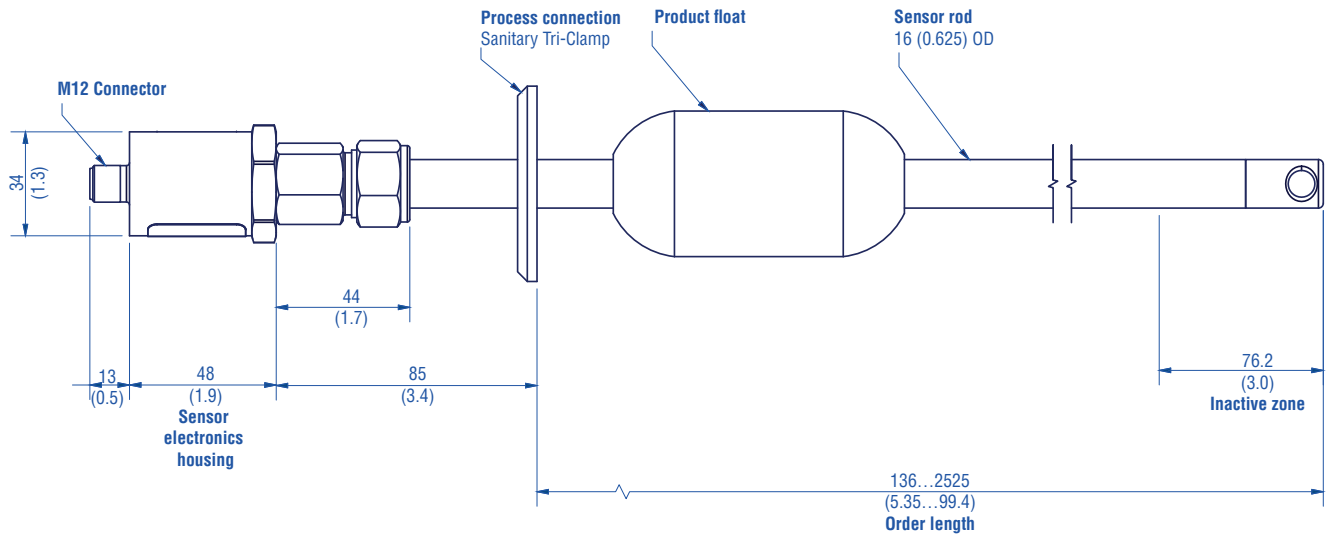

LLH - R-Series

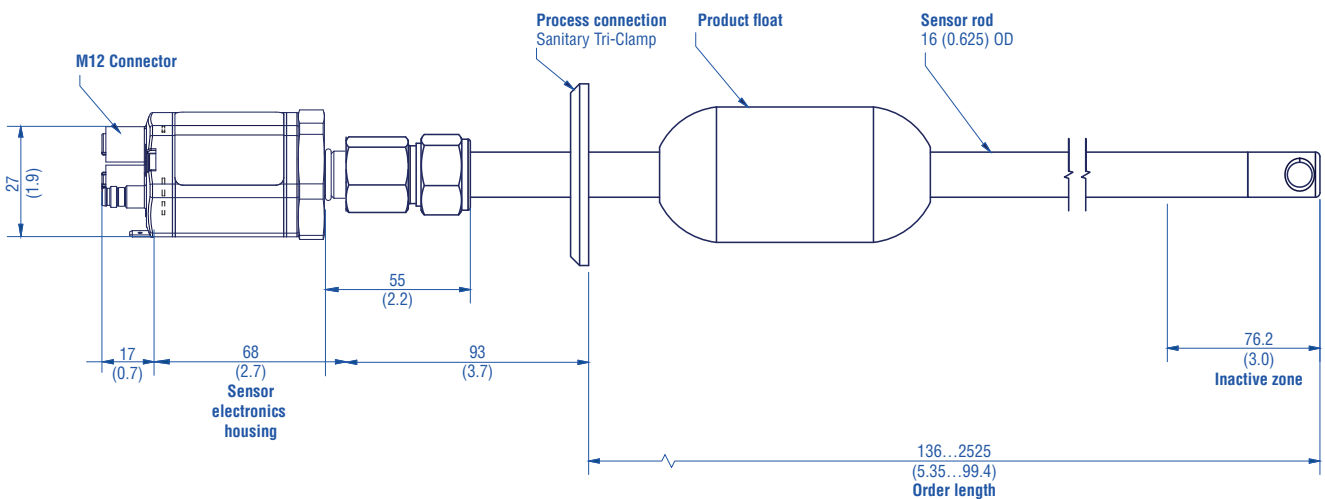

End plug options

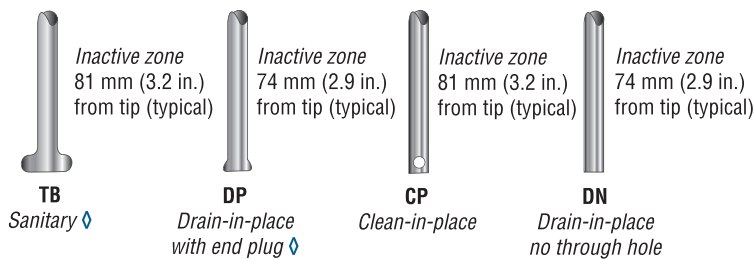

◇ End plug style comes with permanently mounted floats. These floats cannot be removed from the pipe.

Fig. 3: Technical drawing LLH and End plug options

CONNECTOR WIRING

D34 Analog		
Signal + power supply		
M12 male connector (A-coded)	Pin	Function
 <p>View on sensor</p>	1	+24 VDC (-15/+20 %)
	2	Output 1
	3	DC Ground (0 V)
	4	Output 2
	5	DC Ground

Fig. 4: D34 Analog

D34 CAN		
Signal + power supply		
M12 male connector (A-coded)	Pin	Function
 <p>View on sensor</p>	1	Shield
	2	+24 VDC (-15/+20 %)
	3	DC Ground (0 V)
	4	CAN_H
	5	CAN_L

Fig. 7: D34 CAN

D84 SSI		
Signal + power supply		
M12 male connector (A-coded)	Pin	Function
 <p>View on sensor</p>	1	Clock (+)
	2	Clock (-)
	3	Data (+)
	4	Data (-)
	5	Not connected
	6	Not connected
	7	+24 VDC (-15/+20 %)
	8	DC Ground (0 V)

Fig. 6: D84 SSI

D44 IO-Link		
Signal + power supply		
M12 A-coded	Pin	Function
 <p>View on sensor</p>	1	+24 VDC ($\pm 25\%$)
	2	DI/DQ
	3	DC Ground (0 V)
	4	C/Q

Fig. 8: D44 IO-Link

CONNECTOR WIRING



D56		
Port 1 – Signal		
M12 female connector (D-coded)	Pin	Function
 <p>View on sensor</p>	1	Tx (+)
	2	Rx (+)
	3	Tx (-)
	4	Rx (-)
Port 2 – Signal		
M12 female connector (D-coded)	Pin	Function
 <p>View on sensor</p>	1	Tx (+)
	2	Rx (+)
	3	Tx (-)
	4	Rx (-)
Power supply		
M8 male connector	Pin	Function
 <p>View on sensor</p>	1	+12...30 VDC (±20 %)
	2	Not connected
	3	DC Ground (0 V)
	4	Not connected

Fig. 9: D56



D58		
Port 1 – Signal		
M12 female connector (D-coded)	Pin	Function
 <p>View on sensor</p>	1	Tx (+)
	2	Rx (+)
	3	Tx (-)
	4	Rx (-)
Port 2 – Signal		
M12 female connector (D-coded)	Pin	Function
 <p>View on sensor</p>	1	Tx (+)
	2	Rx (+)
	3	Tx (-)
	4	Rx (-)
Power supply		
M12 male connector (A-coded)	Pin	Function
 <p>View on sensor</p>	1	+12...30 VDC (±20 %)
	2	Not connected
	3	DC Ground (0 V)
	4	Not connected

Fig. 10: D58

ORDER CODE

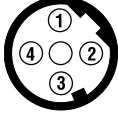

a	Sensor model			
L	L	H	E-Series/R-Series	

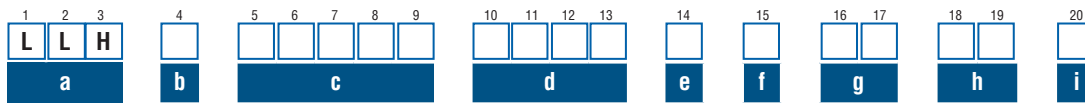
b	Sensors pipe			
C	Sanitary, T-bar, TB			
D	Sanitary, drain-in-place, DP			
E	Sanitary, clean-in-place, CP			
F	Sanitary, drain-in-place, no hole, DN			

c	Order length				
X	X	X	X	M	0127...2525 mm
X	X	X	X	U	005.0...0 99.4 in.

d	Output			
Voltage				
V	1	1	0	10...0 VDC (1 output channel with 1 position magnet)
Current				
A	1	1	0	20...4 mA (1 output channel with 1 position magnet)
U	4	0	1	Profinet RT & IRT
U	4	0	2	Profinet RT & IRT
U	2	0	1	EtherNet/IP™
U	3	0	1	POWERLINK
U	1	0	1	EtherCAT®
L	0	0	0	IO-Link

d	Output				
S	1	B	0	SSI, 25 bit, Binary, 0.1 mm resolution *	
S	1	G	0	SSI, 25 bit, Gray, 0.1 mm resolution *	
S	2	B	0	SSI, 24 bit, Binary, 0.1 mm resolution *	
S	2	G	0	SSI, 24 bit, Gray, 0.1 mm resolution *	
C	3	1	1	CANopen, 1000 kBit/s, 20 um, 1 magnet	
C	3	2	1	CANopen, 500 kBit/s, 20 um, 1 magnet	
C	3	3	1	CANopen, 250 kBit/s, 20 um, 1 magnet	
C	3	4	1	CANopen, 125 kBit/s, 20 um, 1 magnet	
C	4	1	1	CANopen (bus terminator), 1000 kBit/s, 20 um, 1 magnet	
C	4	2	1	CANopen (bus terminator), 500 kBit/s, 20 um, 1 magnet	
C	4	3	1	CANopen (bus terminator), 250 kBit/s, 20 um, 1 magnet	
C	4	4	1	CANopen (bus terminator), 125 kBit/s, 20 um, 1 magnet	
V	1	0	1	10...0 Vdc RH-V	
A	1	0	1	20...4 mA RH-V	

e	Process Connection Type			
1	NPT **			
4	Welded Tri-Clamp			
5	Adjustable Tri-Clamp			
Z	Custom Flange			

f See next page

*/ Measurement direction is set to measure away from housing towards tip.
**/ Only available with Sensor Pipe options E and F.

Level Plus Model LLH

Data Sheet

f	Process Connection Size
A	¾" ***
B	1" ***
C	1½"
D	2"
F	2½"
G	3"
H	4"
J	6"
X	None
Z	Custom Flange

g	Float 1 ****
X	X None
S	1 401513-2
S	5 200931-6
S	7 251234-2
S	8 252228-2
S	9 403374
S	A 560564-2

h	Float 2
X	X None

f	Options
C	5 m cable
X	None



**Manuals, Software & 3D models available at:
www.temposonics.com**

***/ Only available with Sensor Pipe Options E and F and NPT Process Connection Type
****/ Make sure to order the sensor with a process connection large enough to fit the float when ordering Sensor Pipe options E or F.

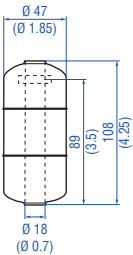
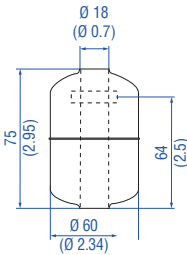
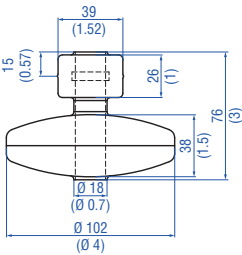
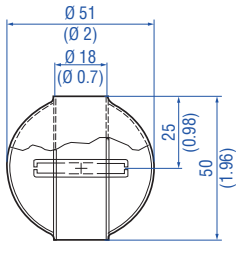
ACCESSORY DETAILS – Accessories shown can be included in the model number when selected.

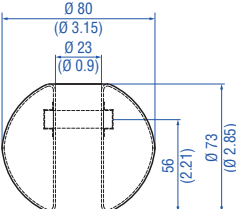
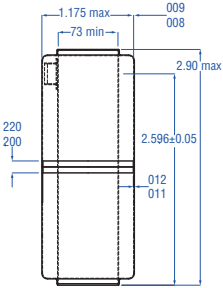
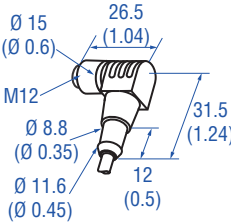
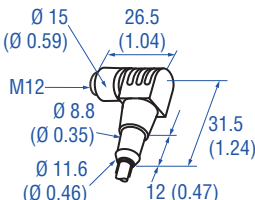
Floats			
			
<p>Float Part no. 401 513-2 Order Code Option „S1“</p>	<p>Float Part no. 200 931-6 Order Code Option „S5“</p>	<p>Float Part no. 252 228-6 Order Code Option „S8“</p>	<p>Float Part no. 251 234-2 Order Code Option „S7“</p>
<p>Material: SS 200 Grit/Ra 25 µm (0.625 µm) Specific gravity: Max. 0.66 Pressure: 10.3 bar (150 psi) Operating temperature: -40...+149 °C (-40...+300 °F)</p>	<p>Material: SS 240 Grit/Ra 15 Specific gravity: Max. 0.63 Pressure: 24.4 bar (325 psi) Operating temperature: -40...+149 °C (-40...+300 °F)</p>	<p>Material: SS 240 Grit/Ra 15 µm (0.375 µm) Specific gravity: Max. 0.48 Pressure: 8.6 bar (125 psi) Operating temperature: -40...+149 °C (-40...+300 °F)</p>	<p>Material: SS 240 Grit/Ra 25 µm (0.625 µm) Specific gravity: Max. 0.74 Pressure: 22.4 bar (325 psi) Operating temperature: -40...+149 °C (-40...+300 °F)</p>

Floats		Cord sets	
			
<p>Float Part no. 560 564-2 Order Code Option „SA“</p>	<p>Float Part no. 403 374 Order Code Option „S9“</p>	<p>Cable with M12 A-coded female connector (5 pin), angled – pigtail Part no. 370 675</p>	<p>Cable with M12 A-coded female connector (8 pin), angled – pigtail Part no. 370 676</p>
<p>Material: SS 240 Grit/Ra 15 µm (0.375 µm) Specific gravity: Max. 0.83-0.86 Pressure: 8.6 bar (125 psi) Operating temperature: -40...+149 °C (-40...+300 °F)</p>	<p>Material: Stainless steel 200 Grit/Ra 25 µm (0.625 µm) Specific gravity: 0.86 Pressure: 5.5 bar (80 psi) Operating temperature: -40...+149 °C (-40...+300 °F)</p>	<p>Material: PUR jacket; black Feature: Shielded Cable length: 5 m (16.4 ft) Ingress protection: IP67 (correctly fitted) Operating temperature: -25...+80 °C (-13...+176 °F)</p>	<p>Cable: Shielded Cable length: 5 m (16.4 ft) Ingress protection: IP67 (correctly fitted)</p>

Cable	
	
<p>Cable with M12 D-coded male connector (4 pin), straight – RJ45 male connector, straight Part no. 530 065</p>	<p>Cable with M8 female connector (4 pin), straight – pigtail Part no. 530 066 (5 m (16.4 ft)) Part no. 530 096 (10 m (32.8 ft)) Part no. 530 093 (15 m (49.2 ft))</p>
<p>Material: PUR jacket; green Feature: Cat 5e Cable length: 5 m (16.4 ft) Cable Ø: 6.5 mm (0.26 in.) Ingress protection M12 connector: IP67 (correctly fitted) Ingress protection RJ45 connector: IP20 (correctly fitted) Operating temperature: -30...+70 °C (-22...+158 °F)</p>	<p>Material: PUR jacket; gray Feature: Shielded Cable Ø: 5 mm (0.2 in.) Operating temperature: -40...+90 °C (-40...+194 °F)</p>

Document Part Number:

552102 Revision B (EN) 03/2025

UNITED STATES
Temposonics, LLC
Americas & APAC Region
3001 Sheldon Drive
Cary, N.C. 27513
Phone: +1 919 677-0100
E-mail: info.us@temposonics.com

GERMANY
Temposonics
GmbH & Co. KG
EMEA Region & India
Auf dem Schüffel 9
58513 Lüdenscheid
Phone: +49 2351 9587-0
E-mail: info.de@temposonics.com

ITALY
Branch Office
Phone: +39 030 988 3819
E-mail: info.it@temposonics.com

FRANCE
Branch Office
Phone: +33 6 14 060 728
E-mail: info.fr@temposonics.com

UK
Branch Office
Phone: +44 79 21 83 05 86
E-mail: info.uk@temposonics.com

SCANDINAVIA
Branch Office
Phone: +46 70 29 91 281
E-mail: info.sca@temposonics.com

CHINA
Branch Office
Phone: +86 21 3405 7850
E-mail: info.cn@temposonics.com

JAPAN
Branch Office
Phone: +81 3 6416 1063
E-mail: info.jp@temposonics.com



temposonics.com