

# Temposonics®

Magnetostrictive Linear Position Sensors

## EP2 IO-Link Data Sheet

- Flexible mounting
- Operating temperature up to +75 °C (+167 °F)
- Smooth & compact

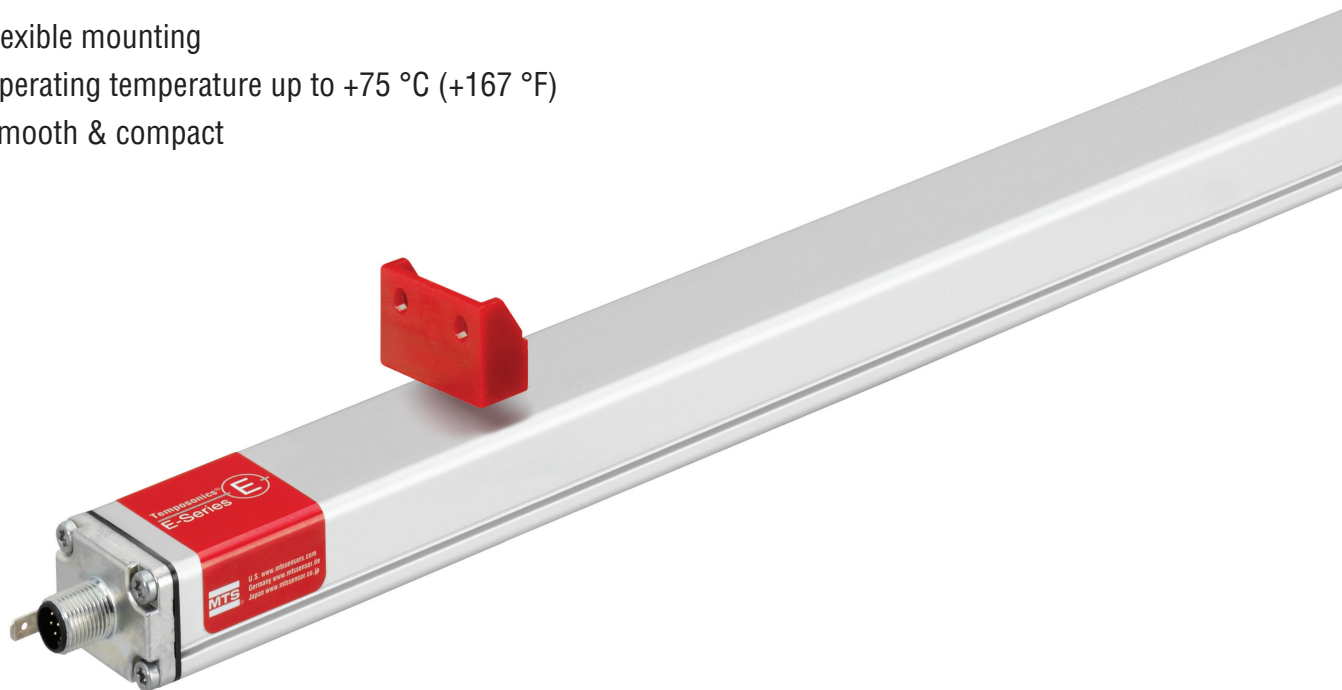

## MEASURING TECHNOLOGY

The absolute, linear position sensors provided by MTS Sensors rely on the company's proprietary Temposonics® magnetostrictive technology, which can determine position with a high level of precision and robustness. Each Temposonics® position sensor consists of a ferromagnetic waveguide, a position magnet, a strain pulse converter and supporting electronics. The magnet, connected to the object in motion in the application, generates a magnetic field at its location on the waveguide. A short current pulse is applied to the waveguide. This creates a momentary radial magnetic field and torsional strain on the waveguide. The momentary interaction of the magnetic fields releases a torsional strain pulse that propagates the length of the waveguide. When the ultrasonic wave reaches the end of the waveguide it is converted into an electrical signal. Since the speed of the ultrasonic wave in the waveguide is precisely known, the time required to receive the return signal can be converted into a linear position measurement with both high accuracy and repeatability.

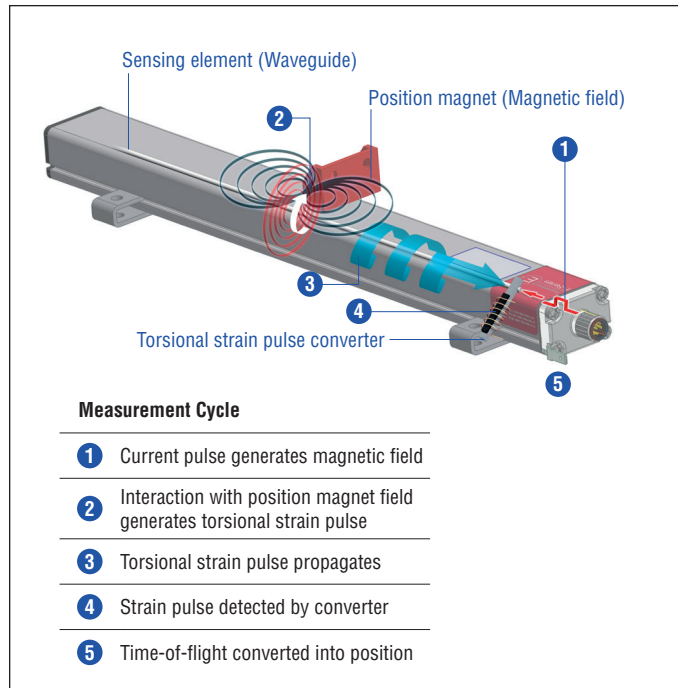

Fig. 1: Time-of-flight based magnetostrictive position sensing principle

## EP2 SENSOR

Robust, non-contact and wear free, the Temposonics® linear position sensor provide high durability and precise position measurement feedback in harsh industrial environments. Measurement accuracy is tightly controlled by the quality of the waveguide manufactured exclusively by MTS Sensors.

The compact and smooth aluminum profile offers flexible mounting options and easy installation. Moreover, the position magnet can travel along the entire flat housing profile. The EP2 is ideal for industrial applications including plastics molding and processing, factory automation and packaging. Temposonics® EP2 with IO-Link allows customers to adjust parameters including measuring direction, resolution or offset. In addition, a switching state can be outputted in parallel to the transfer of the position value. The switching points as well as the switching logic can be parameterized. IO-Link is an open standard according to IEC 61131-9. It is a serial, bi-directional point-to-point connection for signal transmission and energy supply. The bi-directional communication enables consistent communication between sensors and the controller as well as consistent diagnostic information down to the sensor level.



Fig. 2: Plastic granulate for injection molding or extrusion

## TECHNICAL DATA

Output	
Interface	Digital
Transmission protocol	IO-Link V1.1
Data format	32 bit signed (position in $\mu\text{m}$ )
Data transmission rate	COM3 (230.4 kBaud)
Process data device – master	4 bytes
Process data master – device	0 bytes
Error value	0
Measured value	Position
Measurement parameters	
Resolution <sup>1</sup>	5 $\mu\text{m}$ , 10 $\mu\text{m}$ , 20 $\mu\text{m}$ , 50 $\mu\text{m}$ or 100 $\mu\text{m}$
Cycle time	minimum 1 ms (master dependent)
Linearity	$\leq \pm 0.02$ % F.S. (minimum $\pm 90$ $\mu\text{m}$ )
Repeatability	$\leq \pm 0.005$ % F.S. (minimum $\pm 20$ $\mu\text{m}$ )
Operating conditions	
Operating temperature	-40...+75 °C (-40...+167 °F)
Humidity	90 % rel. humidity, no condensation
Ingress protection <sup>2</sup>	IP67 (if mating cable connector is correctly fitted)
Shock test	100 g (single shock) IEC standard 60068-2-27
Vibration test	8 g / 10...2000 Hz IEC standard 60068-2-6 (resonance frequencies excluded)
EMC test	Electromagnetic emission according to EN 61000-6-3 Electromagnetic immunity according to EN 61000-6-2 The sensor meets the requirements of the EC directives and is marked with  .
Magnet movement velocity	Any
Design / Material	
Sensor lid	Zinc die-cast
Sensor profile	Aluminum
Stroke length	50...2540 mm (2...100 in.)
Mechanical mounting	
Mounting position	Any
Mounting instruction	Please consult the technical drawings and the brief instructions (document number: <a href="#">551684</a> )
Electrical connection	
Connection type	M12 (4 pin) male connector
Operating voltage	+24 VDC ( $\pm 25$ %)
Ripple	$\leq 0.28$ V <sub>pp</sub>
Current consumption	< 50 mA
Dielectric strength	500 VDC (DC ground to machine ground)
Polarity protection	Up to -30 VDC
Overvoltage protection	Up to 36 VDC

1/ Selectable via IO-Link master

2/ The IP rating IP67 is only valid for the sensors electronics housing, as water and dust can get inside the profile.

## TECHNICAL DRAWING

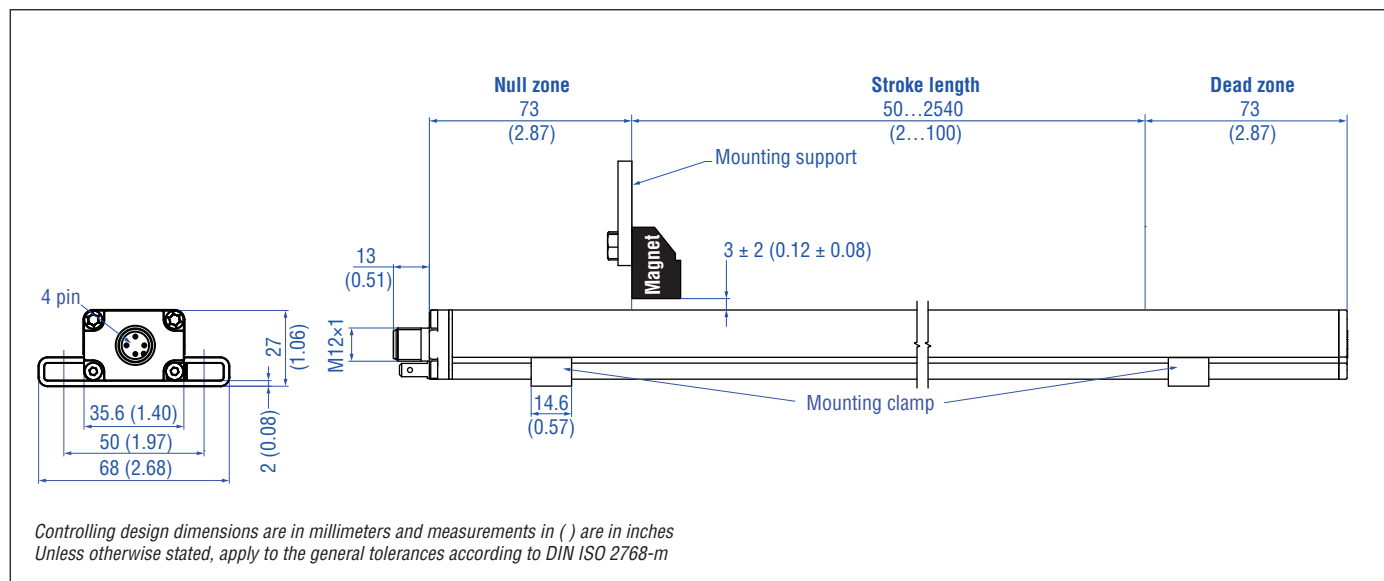

## CONNECTOR WIRING

D44

M12 A-coded	Pin	Function
	1	+24 VDC (±25 %)
	2	DI/DQ
	3	DC Ground (0 V)
	4	C/Q

**FREQUENTLY ORDERED ACCESSORIES** – Additional options available in our [Accessories Guide](#)  [551444](#)

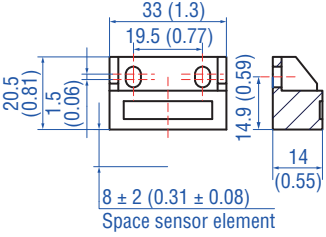
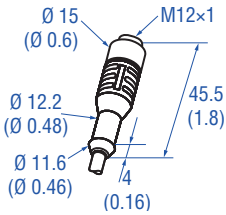
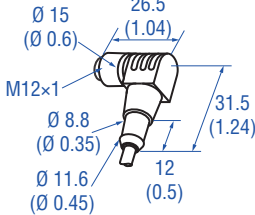
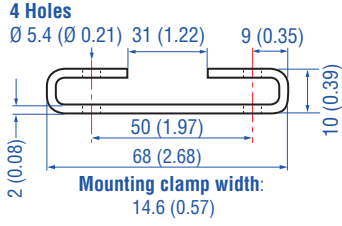
Position magnet	Cord sets	Cord sets	Mounting clamp
 <p>Space sensor element</p>			 <p>Mounting clamp width: 14.6 (0.57)</p>
<p><b>Block magnet L</b> Part no. 403 448</p>	<p><b>M12 (5 pin) female, straight</b> Part no. 370 673</p>	<p><b>M12 (5 pin) female, angled</b> Part no. 370 675</p>	<p><b>Mounting clamp</b> Part no. 403 508</p>
<p>Material: Hard ferrite Weight: Ca. 20 g Operating temperature: –40...+75 °C (–40...+167 °F) Fastening torque for M4 screws: 1 Nm</p>	<p>Ingress protection: IP67 Cable: Shielded, pigtail end Cable length: 5 m (16.4 ft.)</p>	<p>Ingress protection: IP67 Cable: Shielded, pigtail end Cable length: 5 m (16.4 ft.)</p>	

Controlling design dimensions are in millimeters and measurements in ( ) are in inches

## ORDER CODE

1	2	3	4	5	6	7	8	9	10	11	12	13
E	P	2						D	4	4	1	K
a			b					c			d	e

<b>a</b>	<b>Sensor model</b>											
E	P	2	Smooth profile									

<b>b</b>	<b>Stroke length</b>											
X	X	X	X	M	0050...2540 mm							
X	X	X	X	U	002.0...100.0 in.							

### Standard stroke length (mm)\*

Stroke length	Ordering steps
50 ... 500 mm	25 mm
500 ... 2540 mm	50 mm

### Standard stroke length (in.)\*

Stroke length	Ordering steps
2 ... 20 in.	1.0 in.
20...100 in.	2.0 in.

<b>c</b>	<b>Connection type</b>											
D	4	4	M12 (4 pin) male connector									

<b>d</b>	<b>Operating voltage</b>											
1	+24 VDC (±25 %)											

<b>e</b>	<b>Output</b>											
K	IO-Link											

## DELIVERY



- Sensor
- 2 mounting clamps up to 1250 mm (50 in.) stroke length
- + 1 mounting clamp for each 500 mm (20 in.) additional stroke length

Accessories have to be ordered separately.

Operation manuals & software are available at:  
[www.mtssensors.com](http://www.mtssensors.com)

\* / Non standard stroke lengths are available; must be encoded in 5 mm / 0.1 in. increments

