

## G-Series Analog or Start/Stop

Temposonics® GP and GH  
Stroke length 50...7600 mm  
depends on output

Document Part Number  
551383 Revision C



- Rugged industrial sensor
- Linear absolute measurement
- Contactless sensing with highest durability
- Enhanced diagnostics and programming capability
- EMC tested and marked with CE
- Superior accuracy: linearity less than 0.02 % F.S.
- Repeatability less than 0.001 % F.S.
- Direct analog output
- Digital start/stop pulse output

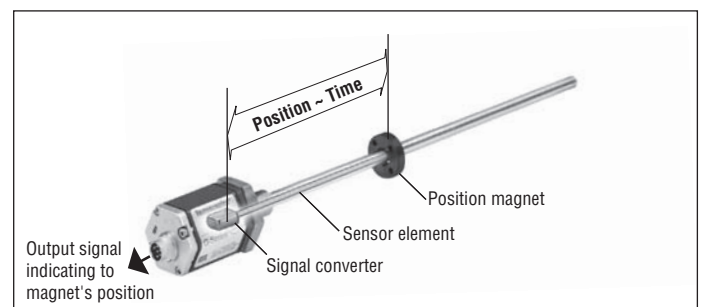

### Magnetostriction

The Temposonics® linear position transducers are based on magnetostriction technology. Magnetostriction is a ferromagnetic material phenomenon which relates a dimensional change of the material to its magnetization properties. It is the product of a general coupling between the magnetic and elastic transport properties of the materials crystal lattice. This affect is typically on the scale of a few parts per million. It is quasi linear with the material's magnetization, may be positive or negative, and reaches a maximum at magnetic saturation. It is reversible, but exhibits a hysteretic affect if the magnetization does so. Magnetostriction was characterized in the late 19th century, the longitudinal version is called the „Joule“ effect, the torsional version is called the „Wiedemann“ effect, and the reciprocal effect where mechanical stress changes the magnetic properties is referred to as the „Villari“ effect.

### Design

The extremely robust sensor, ideal for continuous operation under harshest industrial conditions is completely modular in mechanic and electronic design.

- A profile or rod-shaped sensor housing protects the sensing element in which gives rise to the measurement signal.
- The sensor head accommodates the complete modular electronic interface with active signal conditioning. Double encapsulation ensures high operating safety and optimum EMC protection.
- The position transmitter, a permanent magnet - fixed at the mobile machine part - drives contactlessly over the sensor's stroke and starts measuring through the housing wall.

## Technical data

### Input

Measuring variables	position, liquid level
Stroke length	
- Analog	profile/rod models: 50...2500 mm (longer stroke lengths are available on a custom basis)
- Start/Stop	profile model: 50...5000 mm, rod model: 50...7600 mm

### Output

Voltage	0...10 / 10...0 / -10...+10 / +10...-10 VDC (min. load controller: > 5 kOhms)
Current	4(0)...20 mA / 20...4(0) mA (min/max. load: 0/500 Ohms)
Start/Stop pulse	RS422 serial differential signal

### Accuracy

Position measurement:	
- Null/Span adjustment	100 % of electrical stroke (min. range 50 mm)
- Resolution	analog: infinite digital (start/stop): 0.1 mm; 0.01; 0.005 mm (controller dependent)
- Linearity <sup>1</sup>	< ± 0.02 % F.S. (minimum ± 50 µm)
- Repeatability	< ± 0.001 % F.S. (minimum ± 2.5 µm)
- Hysteresis	< 4 µm
- Update time	analog: < 1 ms typical digital (start/stop): controller and stroke dependent
- Ripple	< 0.01 % F.S.

### Operating conditions

Magnet speed	any
Operating temperature	-40 °C...+80 °C
Dew point, humidity	90% rel. humidity, no condensation
Ingress protection <sup>2</sup>	profile: IP 65, rod: IP 67, IP 68 for cable outlet
Shock test	100 g single hit, IEC-Standard 60068-2-27
Vibration test	15 g / 10...2000 Hz, IEC-Standard 60068-2-6 (resonance frequencies excluded)
EMC test	Electromagnetic emission EN 61000-6-4 (for use in industrial environment) Electromagnetic immunity EN 61000-6-2 The sensor meets the requirements of the EC directives and is marked with CE

### Design, material

Diagnostic display	LEDs beside connector
<u>Profile model:</u>	
Sensor head	aluminum
Sensor stroke	aluminum
Position magnet	magnet slider or removable U-magnet
<u>Rod model:</u>	
Sensor head	aluminum
Rod with flange	stainless steel 1.4301 / AISI 304
-Pressure rating	350 bar, 700 bar peak
Position magnet	Ring magnets, U-magnets

### Installation

Mounting position	any orientation
Profile	movable mounting clamps or T-slot nuts in base channel
Rod	threaded flange M18 x 1,5 or 3/4" -16 UNF-3A, hex nut M18
Position magnet	mounting plate and screws from antimagnetic material

### Electrical connection

Connection type	6 pin connector
Supply voltage	24 VDC (-15 / +20 %); UL Recognition requires an approved power supply with energy limitation (UL 61010-1), or Class 2 rating according to the National Electrical Code (USA) / Canadian Electrical Code.
- Polarity protection	up to -30 VDC
- Overvoltage protection	up to 36 VDC
Current drain	100 mA typical
Ripple	≤ 0.28 Vpp
Electric strength	500 VDC (DC ground to machine ground)

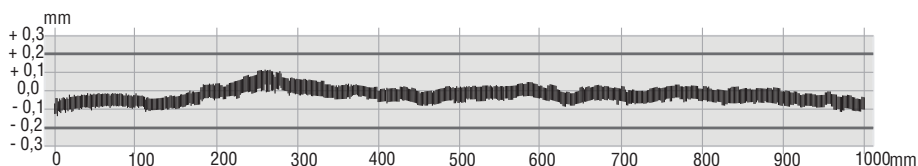

### Linearity protocol example

Sensor Temposonics® GP/GH  
Stroke length 1000 mm  
Tolerance allowed: ± 0.2 mm  
Tolerance measured: typical ± 0.09 mm

<sup>1</sup> with position magnet # 251 416-2.

<sup>2</sup> The IP rating is not part of the UL recognition

**Temposonics® GP – Stable profile design**

Temposonics® GP offers modular construction, flexible mounting configurations and easy installation. Position measurement is contactless via two versions of permanent magnets.

- A sliding magnet running in profile housing rails. Connection with the mobile machine part is via a ball jointed arm to taking up axial forces.
- A floating magnet, mounted directly on the moving machine part, travels over the profile at a low distance. Its air-gap allows the correction of small misalignments at installation.

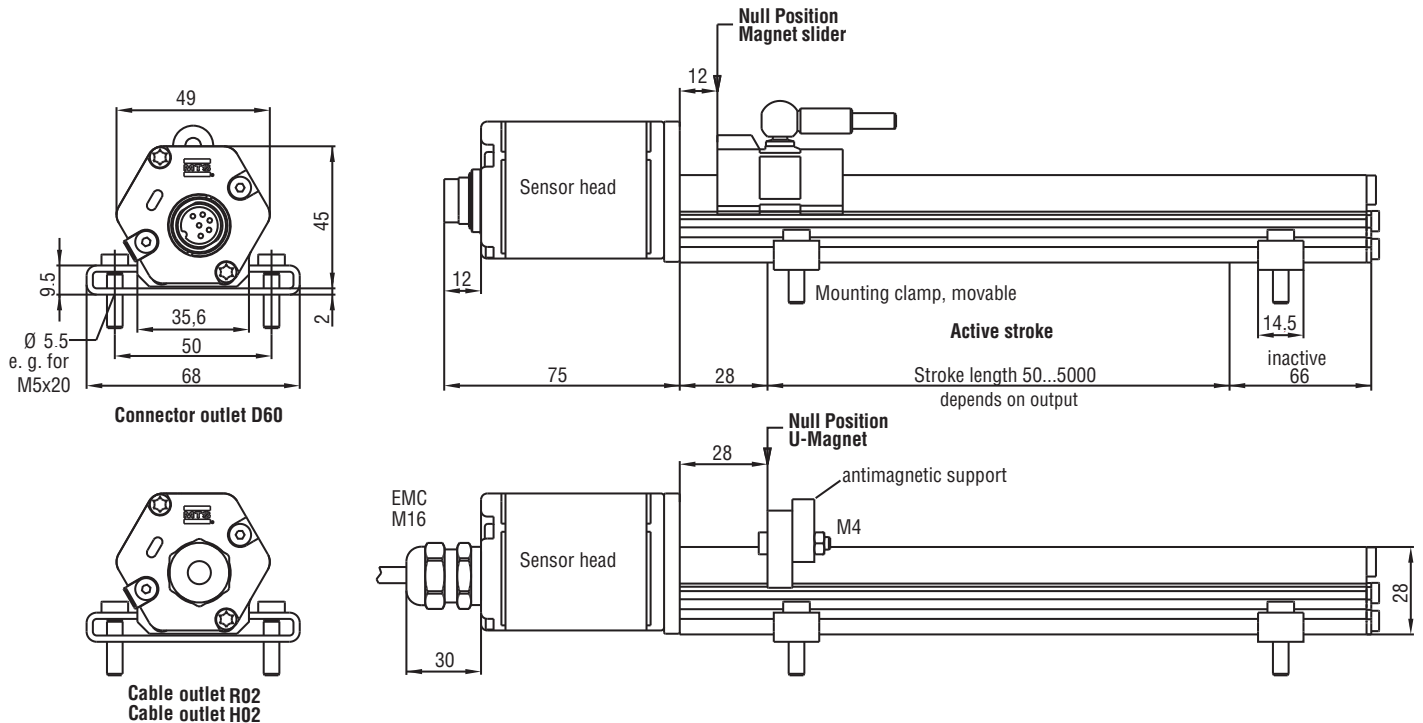

**Position magnets** (not included in delivery, please order separately)

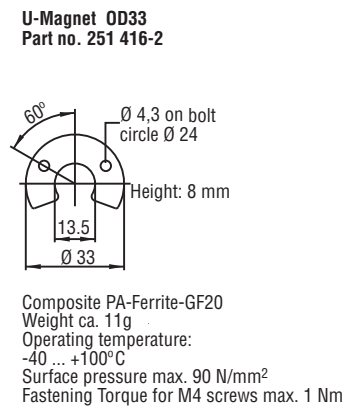
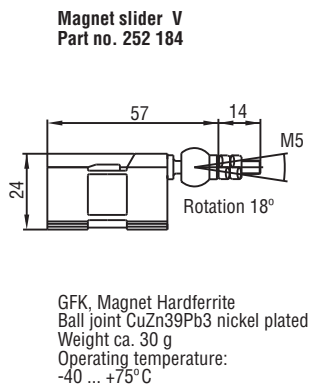
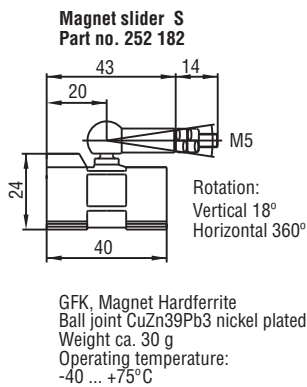

**Other position magnets on request.**

All dimensions in mm

## Temposonics® – High pressure rod design

Temposonics® GH with a pressure-resistant stainless steel flange and sensing rod is suitable for use in hydraulic cylinders and externally in all applications where space is a problem. Position measurement is done via ring or U-magnets travelling along the sensing rod without any mechanical contact.

### Advantage...

the completely operable sensor cartridge can be replaced for servicing easily without opening the fluid circuit.

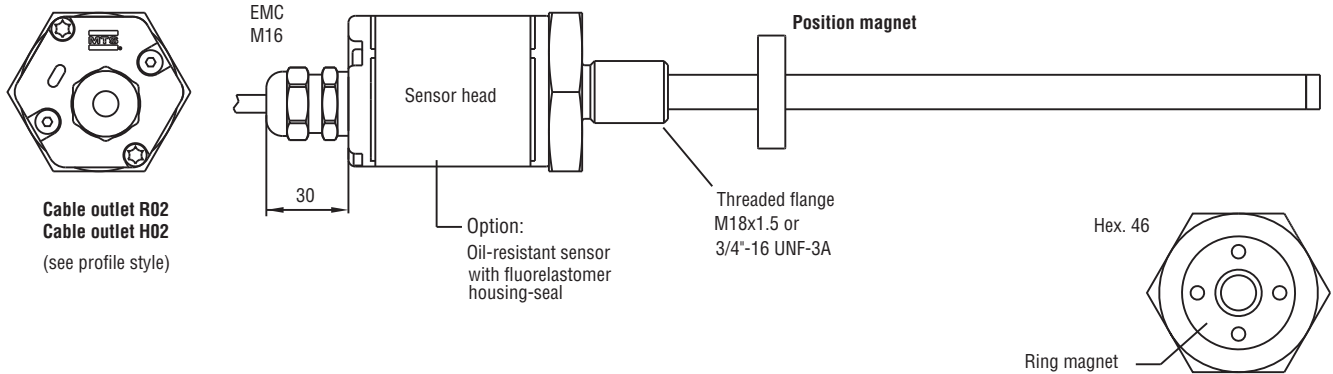
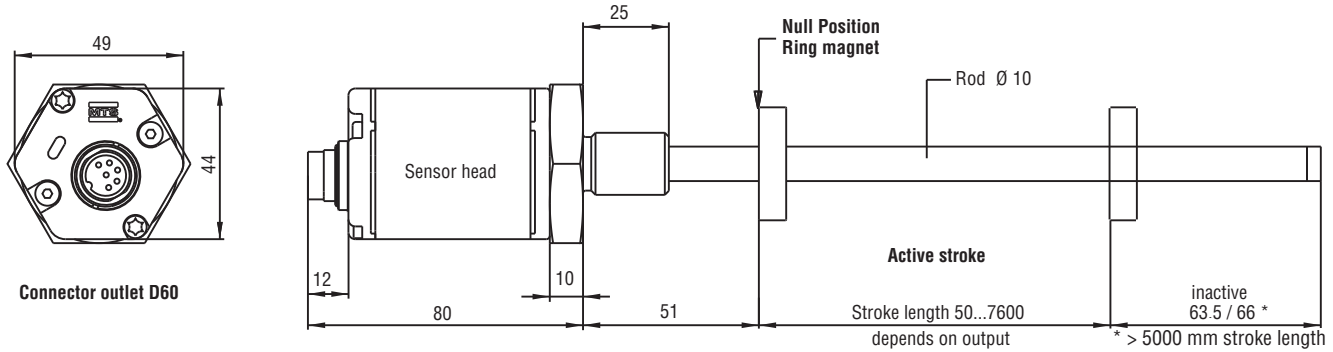

### Position magnets (not included in delivery, please order separately)

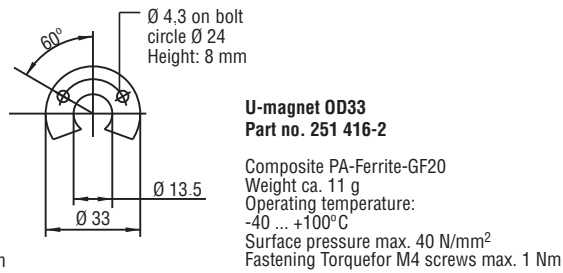
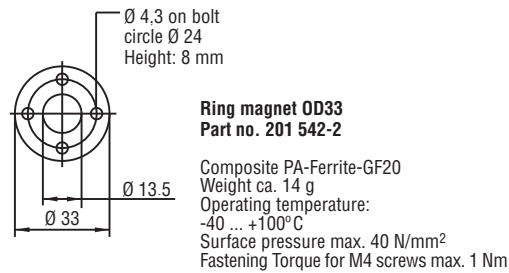

Other position magnets on request.

All dimensions in mm

**Temposonics® G-Series – The next sensor generation**

MTS Sensors is proud to introduce our new G-Series linear position sensors utilizing our next generation technology platform. G-Series sensors feature a microprocessor-based design with enhanced diagnostics and programmability to maximize backwards compatibility.

**Sensor diagnostic display**

Integrated LEDs (green/red) provide basic visual feedback for normal sensor operation and troubleshooting.

LED	Green	Red	Description
ON	ON	OFF	Normal function
ON	ON	Flashing	Missing external start signal
ON	ON	ON	Magnet not detected
Flashing	ON	OFF	Serial programming mode

**Analog output**

Temposonics® G-Series with analog outputs provide direct analog outputs including voltage and current, forward or reverse acting. All outputs allow full adjustment of Null and Span setpoints (minimum range 50 mm between setpoints) inside the active electrical stroke length. Since the outputs are direct, no signal conditioning electronics are needed when interfacing with controllers or meters.

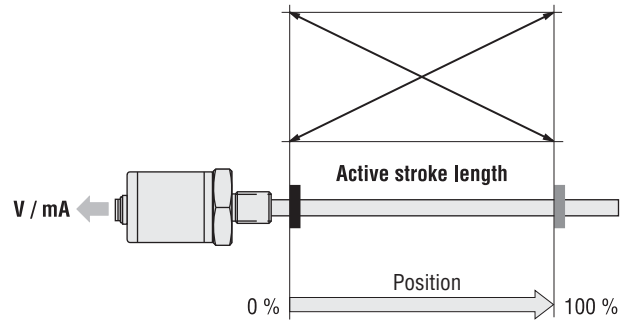

**Connector wiring**

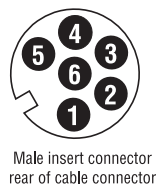

Pin	Cable	Analog	Digital
Pin 1	GY	V/mA	Stop (-)
Pin 2	PK	DC ground	Stop (+)
Pin 3	YE	USB-programmer	Start (+)
Pin 4	GN	USB-programmer	Start (-)
Pin 5	BN	+24 VDC (-15/+20 %)	
Pin 6	WH	DC ground	

**Start/Stop pulse output**

The digital Temposonics® G-Series is equipped with a start/stop output. The sensor requires a start signal from an external indicator in the control system and returns a stop signal corresponding to the magnet's position. The time elapsed between the two signals is proportional to the position. Time measurement is done by the control unit and used for calculating the position value.

Option multi-magnet measurement: One Sensor can detect the positions of several magnets simultaneously.

**Logic diagram**

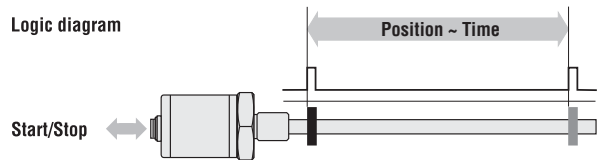

**Connectors** (not included in delivery, please order separately)

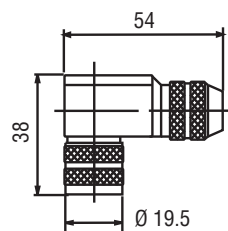
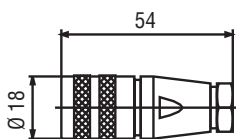

**6 pin female connector M16, PG9**  
**Part no.: 370 423**

Housing: zinc, nickel-plated  
 Termination: solder  
 Contact insert: silver plated  
 Max. cable-Ø: 6...8 mm

**6 pin 90° female connector M16**  
**insert adjustable in 45° positions**  
**Part no.: 370 460**

Housing: zinc, nickel-plated  
 Termination: solder  
 Contact insert: silver plated  
 Max. cable Ø: 6...8 mm

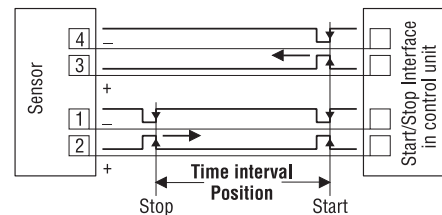

All dimensions in mm

## Flexible installation in any position

### Profile model

Normally, the sensor is firmly installed - fixed on a straight surface of the machine with movable mounting clamps or M5 screws in base channel - whilst the magnet is mounted at the mobile machine part.

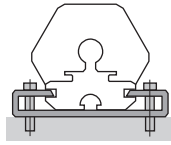

Mounting clamp with screws M5x20  
Tightening torque: max. 5 Nm

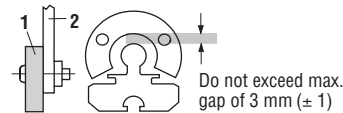
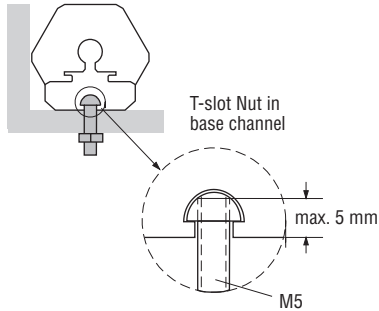

1 U-Magnet  
2 Mounting plate and screws non-ferrous material

### Rod model

Mount the sensor via flange thread or a hex nut. If possible, non-magnetizable material should be used for mounting support (dimensions as shown). With horizontal mounting, longer sensors (from 1 meter) must be provided with mechanical support.

### Hydraulic sealing

Recommended is sealing of the flange facing with O-Ring (e.g. 22,4 x 2,65) in a cylinder cover nut or an O-Ring 15,3 x 2,2 in undercut.

### Minimum assembly distance

1. Non-magnetizable material

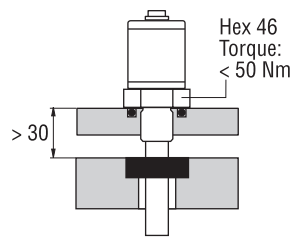

Recommended hydraulic sealing

2. Magnetizable material

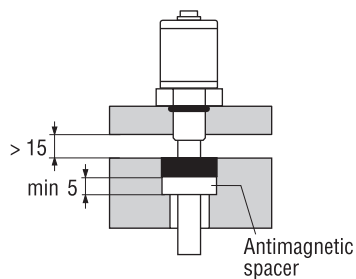

On delivery:  
O-Ring 15,3 x 2,2  
See ISO 6149-1

### Cylinder installation

When used for direct stroke measurement in fluid cylinders, the sensor's high pressure, stainless steel rod should be installed into a bore in the piston head/rod assembly as illustrated. That guarantees a longlife and trouble-free operation - independent from the used hydraulic fluid.

The sensor cartridge can be removed from the flange and rod housing while still installed in the cylinder. This procedure allows quick and easy sensor cartridge replacement, without the loss of hydraulic pressure.

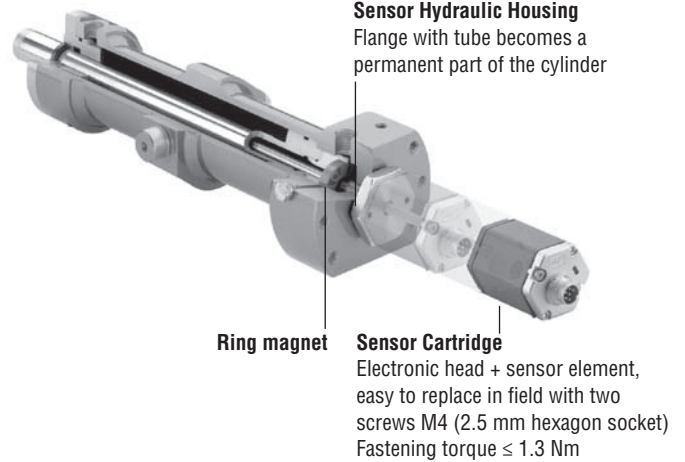

### A liquid level sensor

With installation of the position magnet into a float, the application range of G-series extends substantially. These highly precise float sensors supply exact level values or - provided with suitable floats - interface heights e.g. in the process-industry or laboratory technology etc.

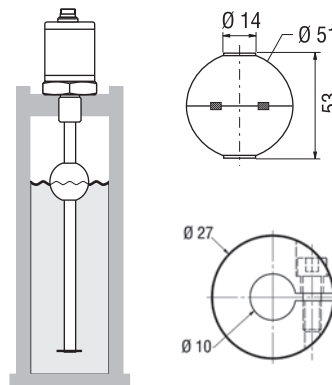

#### Magnet float (upon request) Part no. 251 447

- Density 720 kg/m<sup>3</sup>
- Material 1.4571 polished AISI 316 Ti
- Pressure <math>< 25 \text{ bar}</math>

#### Collar Part no. 560 777

<b>Temposonics® ordering information</b>	<b>G</b>								<b>1</b>			
<b>Sensor model</b> GP - Profile GH - Hydraulic rod												2 or 3 digits
<b>Form factor</b> Profile Temposonics® GP: S - Magnet slider, joint at top V - Magnet slider, joint at front M - U-magnet, OD33 Rod Temposonics® GH: M - Flange M18 x 1,5 (Standard) V - Flange M18 x 1,5 (Fluorelastomer housing-seal) S - Flange 3/4" - 16 UNF - 3A												
<b>Measuring length</b> Analog - Profile/Rod 0050...2500 mm Digital - Profile: 0050...5000 mm / Rod: 0050...7600 mm Standard: up to 1000 in 50 mm, greater 1000 in 250 mm steps Other lengths upon request												
<b>Connection type</b> D60 - 6 pin male receptacle M16 R02 - 2 m PVC cable w/o connector, option: R01...R10 (1...10 m) H02 - 2 m PUR cable w/o connector, option: H01...H10 (1...10 m)												
<b>Supply voltage</b> 1 - +24 VDC												
<b>Output</b> V0 = 0...10 VDC V1 = 10...0 VDC V2 = -10...+10 VDC V3 = +10...-10 VDC A0 = 4...20 mA A1 = 20...4 mA A2 = 0...20 mA A3 = 20...0 mA R01 = Start/Stop - Option: R0X = If more than 1 magnet, denotes number (2...9 pcs.) for start/stop multi-magnet measurement												

**Stroke length standard (GP):**

Stroke length	Ordering steps
≤ 500 mm	25 mm
500...2500 mm	50 mm
2500...5000 mm	100 mm
> 5000 mm	250 mm

**Stroke length standard (GH):**

Stroke length	Ordering steps
< 500 mm	5 mm
500...750 mm	10 mm
750...1000 mm	25 mm
1000...2500 mm	50 mm
2500...5000 mm	100 mm
> 5000 mm	250 mm

**Delivery includes:**

**On delivery profile model:** Sensor, Position magnet, 2 mounting clamps up to 1250 mm  
+ 1 clamp for every additional 500 mm

**On delivery rod model:** Sensor, O-ring, please order magnets separately.

**Accessories**

Description	Part no.
Magnet slider type »S«	252 182
Magnet slider type »V«	252 184
U-Magnet OD33	251 416-2
Ring magnet OD33	201 542-2
Ring magnet OD25.4	400 533
Magnet float	251 447
Collar	560 777
Hex nut	500 018
Mounting clamp	400 802
T-slot nut M5 for base channel mounting	401 602
6 pin female cable connector M16	370 423
6 pin 90°-female cable connector M16	370 460
PVC-cable 3 x 2 x 0.14 mm <sup>2</sup>	530 032
PUR-cable 3 x 2 x 0.25 mm <sup>2</sup>	530 052
MTS-Service tools	
Analog Hand-Programmer G	253 853
Analog USB-Programmer G, incl. power supply 100...240 VAC / 24 VDC, connection cable and CD-ROM	253 145-1
Digital USB-Programmer G, incl. power supply 100...240 VAC / 24 VDC, connection cable and CD-ROM	253 146-1

**UNITED STATES** 3001 Sheldon Drive  
MTS Systems Corporation Cary, N.C. 27513  
Sensors Division Phone: +1 919 677-0100  
E-mail: info.us@mtssensors.com

---

**GERMANY** Auf dem Schüffel 9  
MTS Sensor Technologie 58513 Lüdenscheid  
GmbH & Co. KG Phone: +49 2351 9587-0  
E-mail: info.de@mtssensors.com

---

**ITALY** Phone: +39 030 988 3819  
Branch Office E-mail: info.it@mtssensors.com

---

**FRANCE** Phone: +33 1 58 4390-28  
Branch Office E-mail: info.fr@mtssensors.com

---

**GREAT BRITAIN** Phone: +44 79 44 15 03 00  
Branch Office E-mail: info.uk@mtssensors.com

---

**CHINA** Phone: +86 21 6485 5800  
Branch Office E-mail: info.cn@mtssensors.com

---

**JAPAN** Phone: +81 42 707 7710  
Branch Office E-mail: info.jp@mtssensors.com

---

**Document Part Number:**  
551383 Revision C (EN) 03/2018



[www.mtssensors.com](http://www.mtssensors.com)