



Level Plus® Direct Digital Access (DDA) Tank Gauge

Operation Guide and Installation Manual

<i>Section</i>	<i>Table of Contents</i>	<i>Page</i>
1	INTRODUCTION	1
2	DDA GAUGE DESCRIPTION	2
2.1	Gauge Description	2
2.2	Standard DDA Gauge Specifications (Style D7, D8, D9)	5
2.3	DDA Long Gauge Specifications (Style LDF)	6
3	ORDERING GUIDE	7
3.1	How To Order Level Plus DDA Gauge By Model Number	7
3.2	How To Order Level Plus DDA Flexible Long Gauge By Model Number	8
3.3	Model Number Generation	9
4	INSTALLATION GUIDE	13
4.1	Mounting in a Riser Pipe (Style D7 only)	13
4.2	Flange Mounting	14
4.3	Threaded Mounting of a Gauge	15
4.4	Sanitary (Tri-Clamp®) Mounting	16
4.5	Thermal Expansion Calculations	16
4.6	Long Gauge Installation	17
5	FLOATS	20
6	DDA CABLE REQUIREMENTS	21
6.1	Cable Selection Graphs	29
6.2	Recommended Cable Types	32
6.3	How to Select Cables (for Intrinsically Safe DDA Networks)	35
6.4	DDA Cable Installation Guidelines	40
6.5	DDA Wiring Connections	42
7	DDA POWER SUPPLY REQUIREMENTS	46
8	DDA GAUGE SET-UP	47
8.1	Hardware/Address Programming Switch	47
8.2	Programmable Gauge Parameters	51
9	MAINTENANCE AND TROUBLESHOOTING	55
9.1	Cable Isolation Test	56
9.2	Cable Connectivity Test	57
9.3	Gauge Current and Voltage Tests	62
9.4	Built in Gauge Diagnostics	69
9.5	Replacing Printed Circuit Cards	69
9.6	Reprogramming Digital Cards After Replacement	71
10	HARDWARE/SOFTWARE ENVIRONMENT	72
10.1	DDA/Host Computer Communication Protocol	74
10.2	Network Protocol/Timing Considerations	76
10.3	DDA Command Definitions (Including Protocol Information)	80
10.4	DDA Error Codes	101
APPENDIX A	DDA ERROR CODES	104
APPENDIX B	DDA EPROM REPLACEMENT PROCEDURE	105
APPENDIX C	ASCII CHARACTER CHART	106
APPENDIX D	COMPLETE ADDRESS DECODING (SWITCH SETTINGS)	107

Phone/Fax Numbers

Phone: 800-457-6620
919-677-2554
Fax: 800-943-1145
919-677-2545

Shipping Address

MTS Systems Corporation
Sensors Division
3001 Sheldon Drive
Cary, NC 27513

Hours

Monday - Friday
7:30 am to 5:30 pm EST

1 INTRODUCTION

The Direct Digital Access (DDA) gauge is a member of the Level Plus® product line. The DDA satisfies the demand for a digital communication interface in the liquid level marketplace.

The digital microprocessor hardware design features surface mount technology with modular, replaceable electronic assemblies. In addition, the microprocessor firmware features a flexible command interface, high noise rejection capability, built in test functions, and automatic data error checking.

The DDA uses EIA485 data communications allowing a direct interface to all types of computers and digital communication equipment.

Standard features of the DDA include the following:

- Long cable runs
- Up to 20 sensors on a 4-wire network
- High noise immunity
- Simple communication protocol
- Intrinsically safe using approved safety barriers
- Field replaceable electronics

2 GAUGE DESCRIPTION

The Level Plus DDA gauge is composed of an aluminum housing coupled with three concentric tubes. The outermost tube serves as a protective jacket for the level and temperature sensing components. The protective jacket is stainless steel (for food, aggressive materials, or hydrocarbon products), or a plastic such as Teflon® (for particular harsh chemical environments).

Up to five Resistive Temperature Devices (RTDs) can be mounted on the inner tube assembly inside the outer protective jacket. Each RTD is a 1000Ω platinum film device, with an inherent accuracy of $\pm 0.5^{\circ}\text{F}$.

The innermost tube comprises the waveguide, the key component in magnetostrictive technology. Unique properties inherent to the waveguide material allow for precision level measurement. The waveguide has a very small diameter and is made of a proprietary magnetostrictive material. Characteristics of this material enable the sensor to have excellent aging and temperature properties.

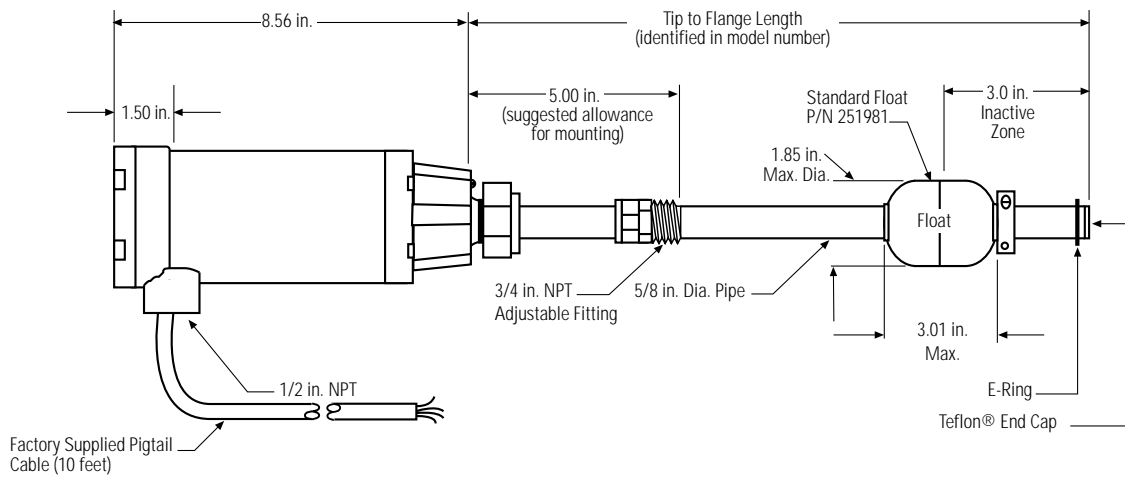

Figure 2.1 The Level Plus Direct Digital Access Gauge

2.1 Operation

The Level Plus gauge precisely senses the position of an external float by applying a short ($2\mu\text{s}$) low power current pulse to the waveguide. This current pulse travels at the speed of light and causes a magnetic field to surround the waveguide. The magnets installed within the level floats also create magnetic fields. When the magnetic fields from the waveguide and a float intersect, a rotational force is created. This in turn, creates a torsional pulse that travels along the waveguide. See figure 2.2.

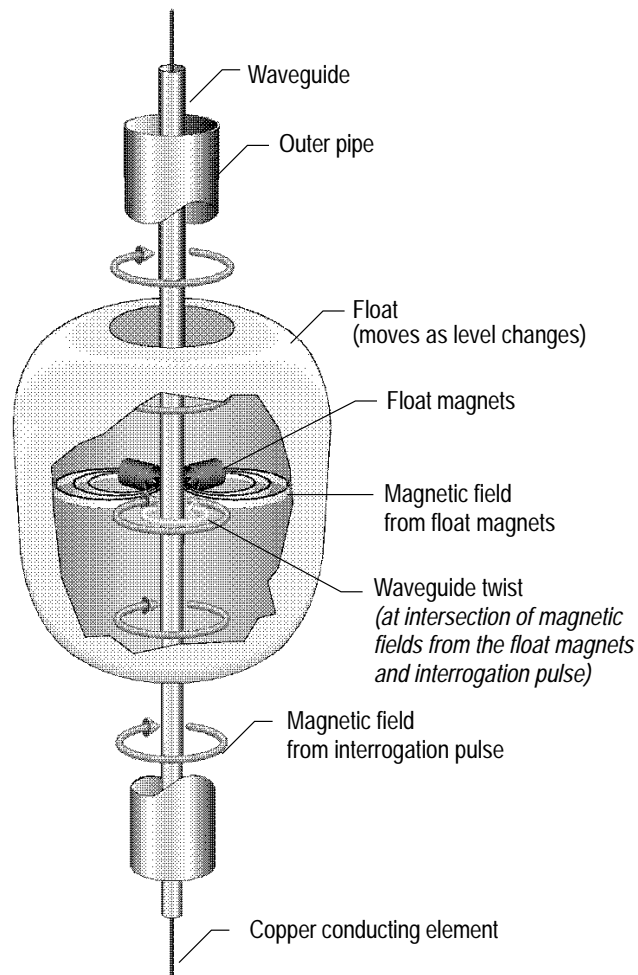

Figure 2.2 Magnetostrictive Operating Principle

The head of the gauge houses the sensing circuit, which detects the torsional pulse and converts it to an electrical pulse. The distance from a reference point to each float is determined by measuring the time interval between the initiating current pulse and the return pulse, and by knowing the speed of these pulses through the waveguide medium. Microprocessor controlled electronics and firmware are used to sample the time based signals many times per second. The resulting data is sorted and averaged to provide rejection of unwanted signals generated by external sources. The filtered data is then converted to level information and output through the communication interface in direct ASCII coded characters.

Temperature measurements are made through internally installed RTDs. See Figure 2.3. A low level current is passed through each RTD (resistive thermal device) to generate a voltage that is proportional to temperature. The voltage is then converted to digital count information using an integrating analog to digital (A/D) converter chip. The digital count information is sorted and averaged to provide rejection of unwanted signals generated by external sources. The filtered data is then converted to temperature information and output through the communication interface in direct ASCII coded characters.

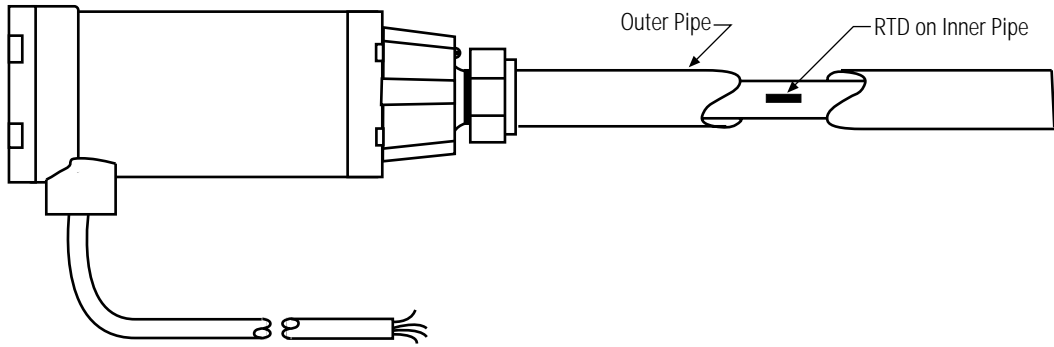

Figure 2.3 RTDs on Inner Tube

2.2 Standard DDA Gauge Specifications (Style D7, D8, D9)

PERFORMANCE:

<i>Parameter</i>	<i>Specification</i>
Measured Variable:	Product level, interface level, temperature
Full Range:	2 to 25 ft. (0.6 to 7.62 m)
Accuracy:	0.025% F.S. or 1/32 inch (0.794 mm)* (includes non-linearity, hysteresis and repeatability)
Hysteresis:	0.001% F.S. or 0.005 in. (0.127mm)*
Repeatability:	0.001% F.S. or 0.001 in. (0.025 mm)*
Resolution:	± 0.001 in. (0.025mm)
Time Constant:	0.5 second (typical)
Input Voltage Range:	24 to 26 VDC at safety barrier input; 8.0V minimum at sensor terminals
Reverse Polarity Protection:	Internal series diodes
Transient Protection:	STYLE D7: Single stage line-to-line transient suppressors; 1500 Watts peak (10/1000 µsec.) STYLE D7, D8: Stage 1: line-to-ground surge suppressors; 2500 Amps peak (8/20 µsec.) Stage 2: line-to-line and line-to-ground transient suppressors; 1500 Watts peak (10/1000 µsec.)
Safety Approval:	Factory Mutual Research Corporation (FMRC) and CSA Intrinsic Safety approval for Class I, II, III, Division 1, Groups C, D, E, F, G hazardous areas

CALIBRATION:

<i>Parameter</i>	<i>Specification</i>
Zero Adjust Range:	Software selectable along entire sensor stroke. No field adjustment required.

ENVIRONMENTAL:

<i>Parameter</i>	<i>Specification</i>
Sealing:	O-ring sealed for outdoor use (NEMA 4)
Humidity:	0 to 100% R.H.
Operating Temperature:	Electronics, all styles: -40 to 149°F (-40 to 65°C) Waveguide: -30 to 160°F (-34 to 71°C) D9 waveguide (optional): -30 to 300°F (-34 to 149°C)
Temperature Sensitivity:	< 0.001% per °C (0.0005% per °F)
Vessel Pressure:	1.896 MPa Maximum (275 PSIG)
Materials:	Wetted: Standard - 316 stainless steel, Optional - Hastelloy®, Teflon® Non-wetted: Epoxy painted aluminum
Minimum Life Expectancy:	10 years

FIELD INSTALLATION REQUIREMENTS:

<i>Parameter</i>	<i>Specification</i>
Length (excluding housing):	2 to 25 ft. (0.6 to 7.62 m)
Housing Dimensions:	3.75 in. (9.53 cm) diameter x 8.6 in. (21.8 cm) long
Mounting:	3/4 in. NPT adjustable fitting; 2 1/2 in. (6.35 mm) sanitary fitting available as option
Wiring:	4 wire connections of shielded cable to factory provided pigtail cable (10 feet) through 1/2 in. NPT conduit opening

All specifications are subject to change without notice. Consult MTS for verification of specifications critical to your needs.

*Whichever is greater

2.3 DDA Long Gauge Specifications (Style LDF)

PERFORMANCE:

<i>Parameter</i>	<i>Specification</i>
Measured Variable:	Product level, interface level, temperature
Full Range:	10 to 60 ft. (7.6 to 18.3 m)
Accuracy:	0.005% F.S. or .020 inch (0.508 mm)* (includes non-linearity, hysteresis, and repeatability)
Hysteresis:	0.002% F.S. or 0.015 in. (0.381mm)*
Repeatability:	0.001% F.S. or 0.005 in. (0.025 mm)*
Resolution:	± 0.001 inch (0.025mm)
Time Constant:	1 second (typical)
Input Voltage Range:	24 to 26 VDC at safety barrier input; 8.0V minimum at sensor terminals
Reverse Polarity Protection:	Internal series diodes
Transient Protection:	STYLE LDF: Stage 1: line-to-ground surge suppressors; 2500 Amps peak (8/20 µsec). Stage 2: line-to-line and line-to-ground transient suppressors; 1500 Watts peak (10/1000 µsec.)
Safety Approval:	Factory Mutual Research Corporation (FMRC) Intrinsic Safety approval for Class I, II, III, Division 1, Groups C, D, E, F, G hazardous areas CSA approval pending

CALIBRATION:

<i>Parameter</i>	<i>Specification</i>
Zero Adjust Range:	Software selectable along entire sensor stroke. No field adjustment required.

ENVIRONMENTAL:

<i>Parameter</i>	<i>Specification</i>
Sealing:	O-ring sealed for outdoor use (NEMA 4)
Humidity:	0 to 100% R.H.
Operating Temperature:	Electronics: -40 to 149°F (-40 to 65°C) Waveguide: -30 to 160°F (-34 to 71°C)
Temperature Sensitivity:	<0 .001% per °C (0.0005% per °F)
Vessel Pressure:	1.896 MPa Maximum (275 PSIG)
Materials:	Wetted: Standard 316 stainless steel Non-wetted: Epoxy painted aluminum
Minimum Life Expectancy:	10 years

FIELD INSTALLATION REQUIREMENTS:

<i>Parameter</i>	<i>Specification</i>
Length (excluding housing):	10 to 60 ft. (7.62 to 18.3 m)
Housing Dimensions:	Electronics housing: 3.75 in. (9.53 cm) diameter x 8.6 in. (21.8 cm) long Condulet housing: approximately 5 inches (127 mm)
Mounting:	1 in. NPT adjustable fitting
Wiring:	4 wire connections of shielded cable to screw terminals through 3/4 in. NPT conduit opening in condulet housing

All specifications are subject to change without notice. Consult MTS for verification of specifications critical to your needs.

*Whichever is greater

3 ORDERING GUIDE

3.1 How to Order Level Plus DDA Gauge by Model Number

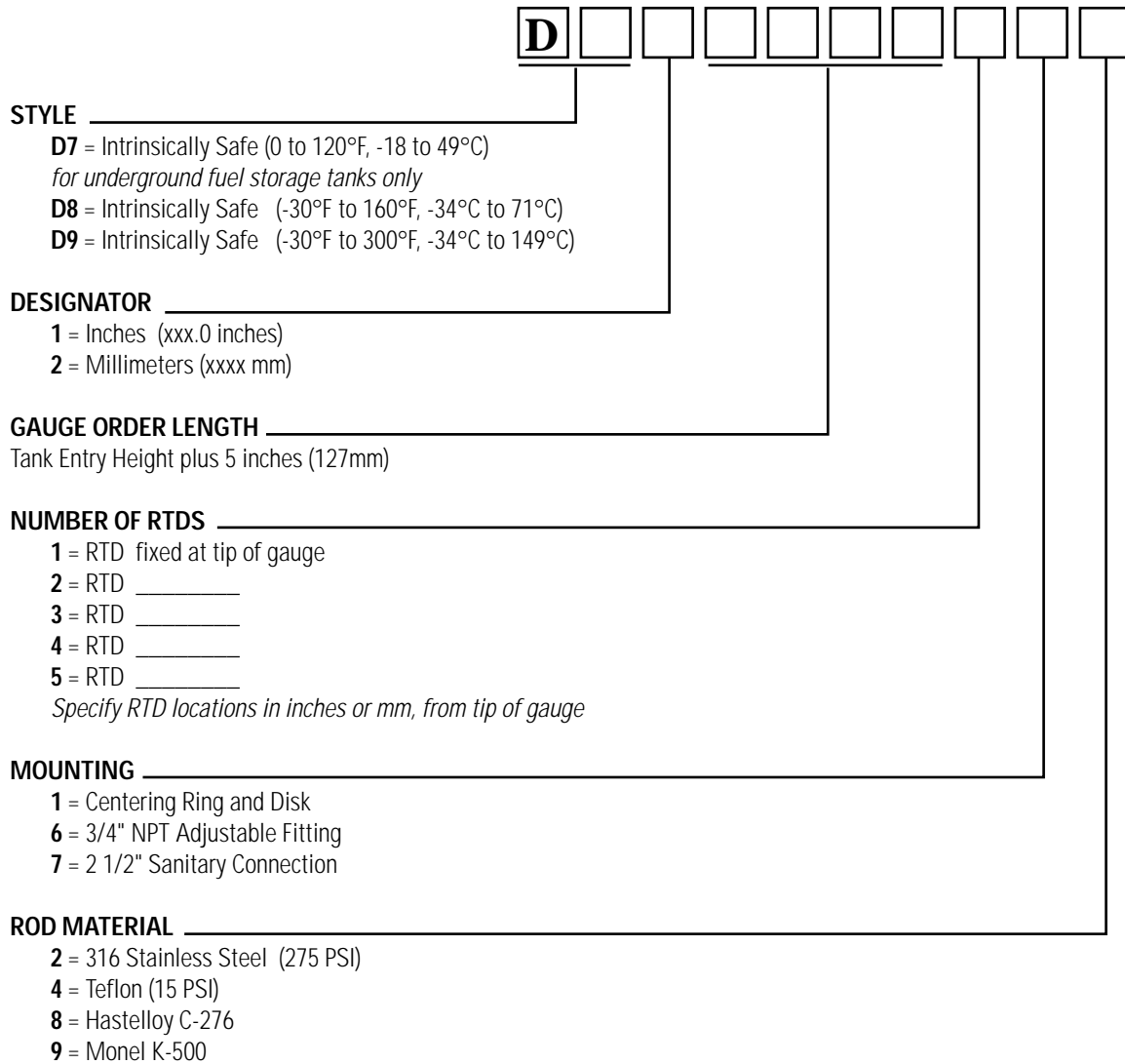

NOTE: Application Data Sheet is required for all orders.

Figure 3.1A Level Plus Direct Digital Access Model Numbering Scheme

3.2 How to Order Level Plus DDA Flexible Long Gauge by Model Number

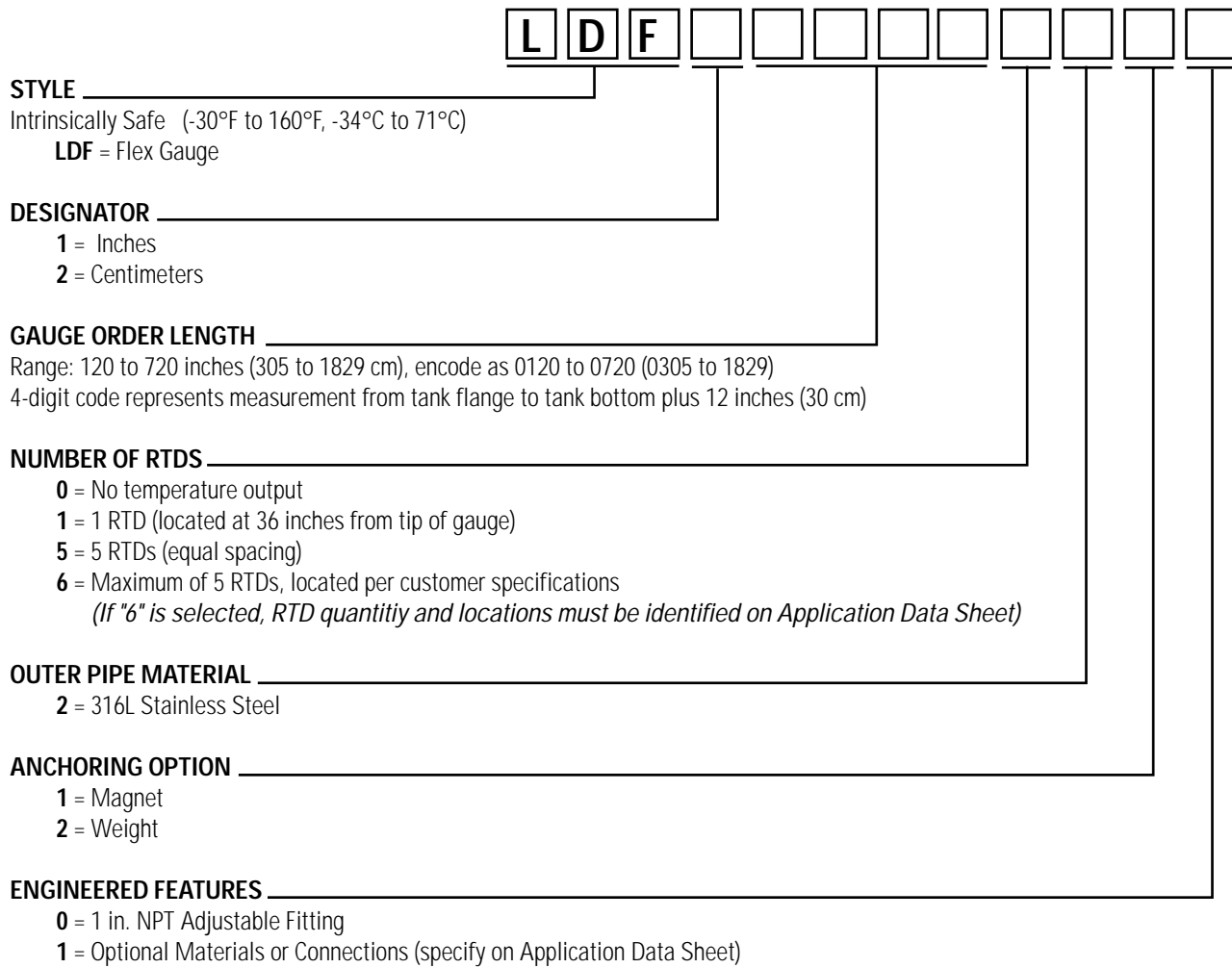

NOTE: Application Data Sheet is required for all orders.

Figure 3.1B Level Plus Direct Digital Access Long Gauge Model Numbering Scheme

3.3 Model Number Generation

The following information describes the fields in the Level Plus DDA gauge model numbering scheme. Information about the gauge is based on this number, and should be reported regarding questions about the gauge.

STYLE: D7, D8, D9 & LDF

The styles of the Level Plus gauges are D7, D8, D9 and LDF. They describe the gauge as being Direct Digital Access.

Style D7: The D7 gauge has a temperature measurement range of 0 to 120°F (-18 to 49°C) and is intended for use only in underground fuel storage tanks with riser pipes. The electrical connection for this style gauge is made to the factory provided pigtail connection through a water tight seal on the cover of the gauge.

Style D8: The D8 gauge has a temperature measurement range of -30° to 160°F (-34° to 71°C) and is primarily used for product measurement in above-ground storage tanks.

Style D9: The D9 gauge has a temperature measurement range of -30° to 300°F (-34° to 149°C) and is intended for high temperature product level and temperature measurement in above-ground chemical process storage tanks.

Style LDF: The LDF gauge has a temperature measurement range of -30° to 160°F (-34° to 71°C) and is intended for product inventory and temperature measurement in large above-ground bulk storage tanks.

Electrical connections for D8 and D9 gauges are made to the factory provided pigtail connection through a 1/2 inch NPT entry hole on the side of the gauge housing.

Electrical connections for the LDF gauge are made through a 3/4 inch NPT entry hole in the side conduit housing.

Designator

The designator is a single digit indication of engineering units used throughout the description. This may be either US customary or metric and the choices for the standard gauge (Style D7, D8, D9) are either 1 for inches and tenths, or 2 for millimeters; for the long gauge (Style LDF) the choices are 1 for inches and tenths of an inch or 2 for centimeters.

Gauge Order Length

For all style DDA gauges the gauge order length is measured from the face of the MTS housing flange to the end of the outer stainless steel tube. This is illustrated in Figures 3.2, 3.3, 3.4, 3.5 and 3.6.

The area marked “inactive zone” is a non-readable section of the sensor stroke. Certain float designs provided by MTS allow the gauge to sense liquids below this area, others may require the use of a special collar to keep the floats out of this region. Floats may be allowed into this region but the software interface will generate error messages indicating this condition. This inactive region must be considered in each level sensing application. Contact an MTS Applications Engineer for additional information.

Number of RTDs

This number refers to the platinum film RTDs that are mounted between the outer protective tube and the second tube. The number can range from 1 to 5.

NOTE

The RTD locations can be specified by the customer at no additional charge. If this option is not selected, the RTDs are placed at equal spacing starting with the first RTD located at the gauge tip

Mounting Hardware

The gauge may be mounted in several ways. These include mounting in a 4 inch diameter riser pipe, an adjustable thread mounting for a flange and a sanitary flange (Tri-Clamp) mounting. The following standard options are available:

Centering Ring and Disk

This option, shown in Figure 3.2 is selected when the gauge must be held centered in a 4-inch riser pipe, as in an underground gasoline tank. The Nylon® disks are mounted to the top and bottom of the gauge head, to center the head within the tank riser pipe.

Condulet Entry and Threaded Adjustable Fitting

This option is selected when a conduit connection in conjunction with adjustable flange mounting is required. See figures 3.3 and 3.6.

Condulet Entry and Sanitary Connector

This option is selected when a conduit connection in conjunction with a sanitary pipe flange (Tri-Clamp) connection is required. See figures 3.4 and 3.5.

Rod Material

The rod material describes the type of material the Level Plus gauge rod will be constructed from.

- 316 stainless steel (rated for 275 PSI maximum)
- Teflon (rated for 15 PSI maximum)
- Hastelloy C-276 (rated for 275 PSI maximum)
- Monel K-500 (rated for 275 PSI maximum)

Other gauge rod materials can be provided. Contact factory for additional information.

Additional Information

In addition to the model number, you must supply the following information: the material used in the floats (floats are available in 316 stainless steel, Teflon, Hastelloy, or Nitrophyl®), the float type, specific gravity, concentration and temperature of the product and interface being measured.

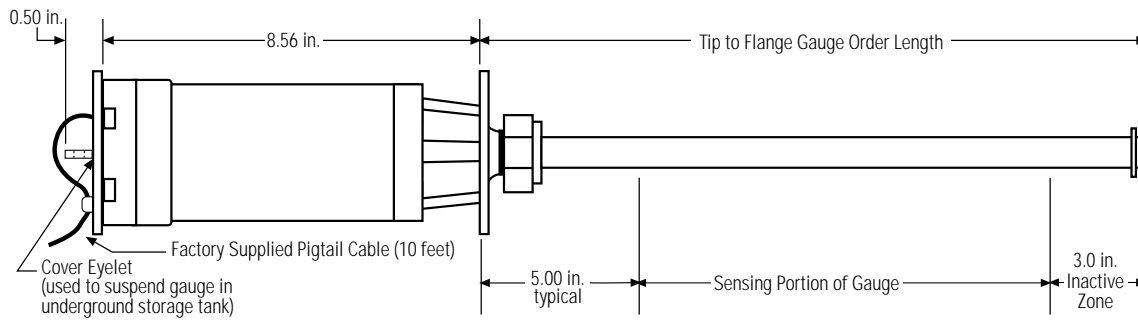

Figure 3.2 Style D7 with wire entry on cover and centering disks

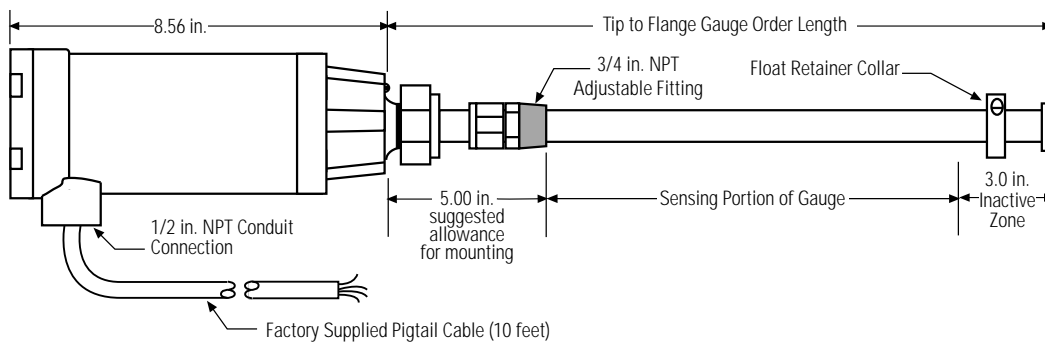

Figure 3.3 D8 and D9 style with adjustable fitting

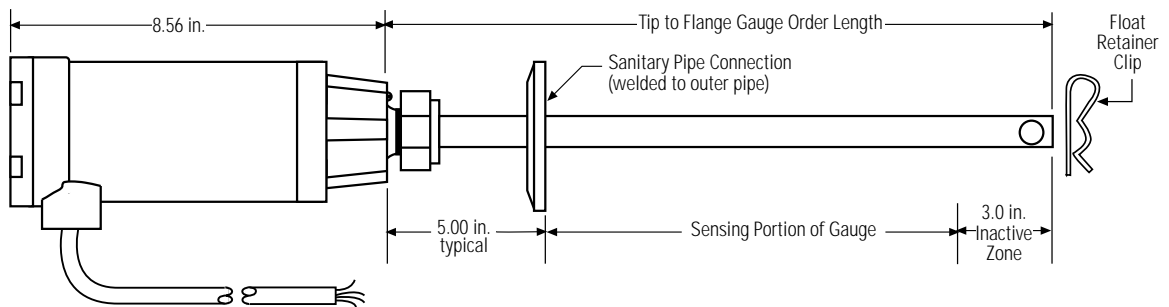

Figure 3.4 Clean in Place style

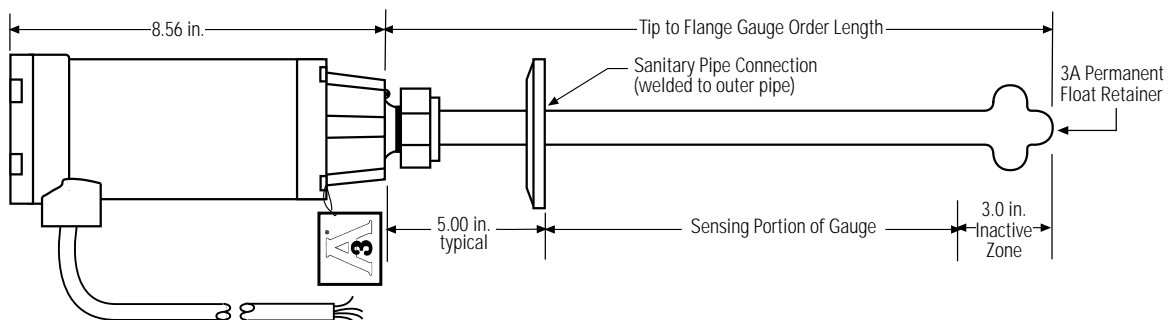

Figure 3.5 3A Sanitary style

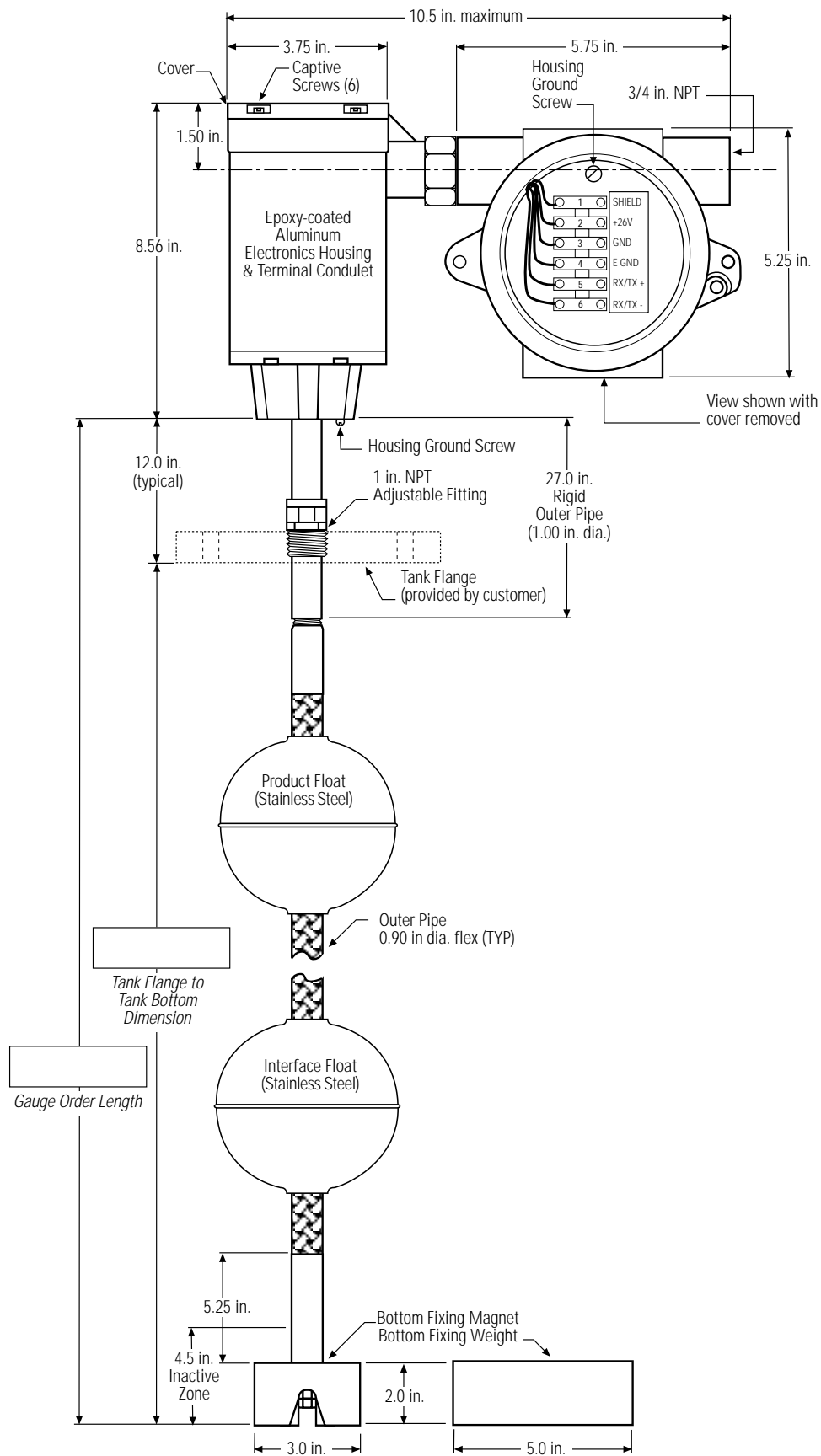

Figure 3.6 LDF Flexible Style

4 INSTALLATION GUIDE

The method of mounting the gauge is dependent on the tank in which it is being used. For purposes of illustration, the four most common means are discussed. These are, in the order in which they are represented, mounting in a riser pipe of an underground tank; mounting in a threaded opening, either directly in the tank or in a reworked blind flange; flange mounting; and long gauge flange mounting.

4.1 Mounting in a Riser Pipe (Style D7 only)

Underground storage tanks (USTs) normally have a riser pipe available for mounting of a level gauge. The location of the pipe should be as near to the center of the tank as possible in order to eliminate the effects of any tilt in the tank. The riser pipe should be a standard 4 inch schedule 40 pipe to allow for adequate space for insertion of the gauge and floats. When mounting a gauge in a riser pipe, indicate the self-centering ring and disk option in the gauge model number when ordering. The buyer is responsible for providing a device to position or mount the gauge vertically.

The gauge is lowered into the riser pipe, resting the bottom of the rod on the bottom of the tank. The cap for the riser pipe may be modified to accept the device to raise or lower the gauge, as well as to allow the signal cable to exit the tank. There is a plastic cap on the bottom of the gauge to eliminate problems associated with galvanic action with the tank itself. However, it is a recommended practice to raise the gauge at the riser cap device, so that the gauge sits slightly above the bottom of the tank to eliminate possible physical problems with direct contact. The diagrams in Figure 4.1 and 4.2 illustrate gauges mounted in a riser pipe of an underground tank.

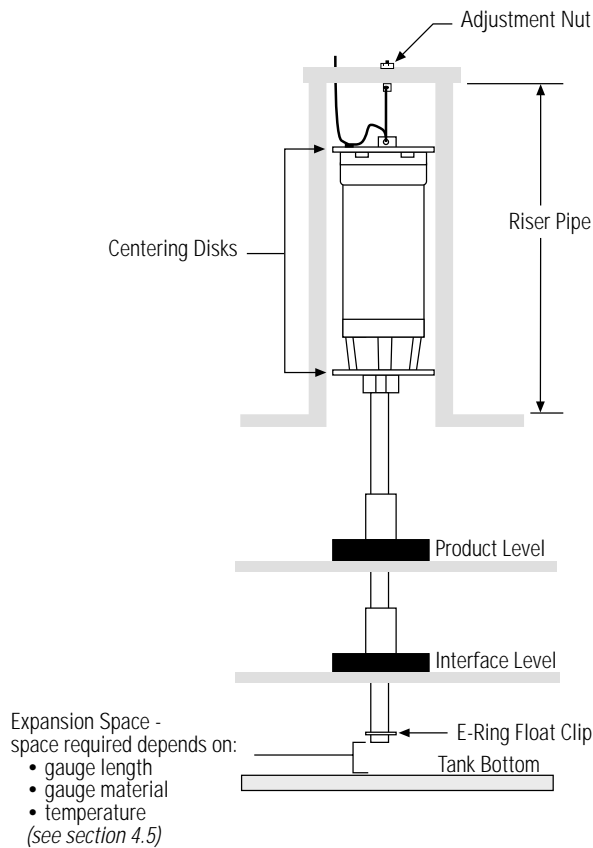

Figure 4.1
UST Mounting Supported at Top

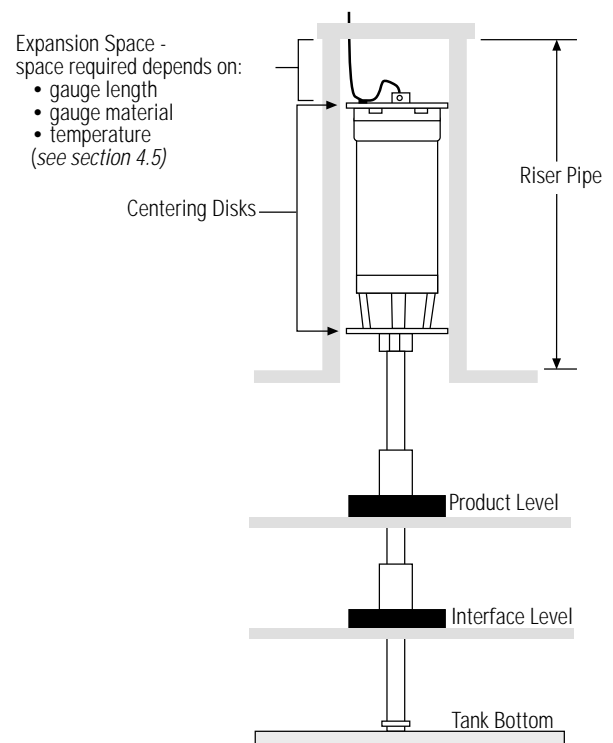

Figure 4.2
UST Mounting Supported by Rod at Bottom

4.2 Flange Mounting

The gauge can also be mounted in a blind flange that has been drilled and tapped to accept it. First, remove the float(s) from the gauge by removing the float securing clip (E-ring) and/or steel collar. Second, mount the gauge in the flange and reinstall the float(s), including the steel collar and float securing clip. Third, mount the gauge, flange and float(s) as a unit onto the tank.

As the tank geometry changes with filling, the gauge must be appropriately sized to take this into account. The gauge can be held in its vertical position with bottom fixing hardware without taking the tank out of service. In most applications, the gauge should be raised off the bottom approximately one-half inch before the fitting is tightened. This will allow for expansion of the pipe due to temperature changes. Refer to the equation in section 4.5 to determine the required expansion space.

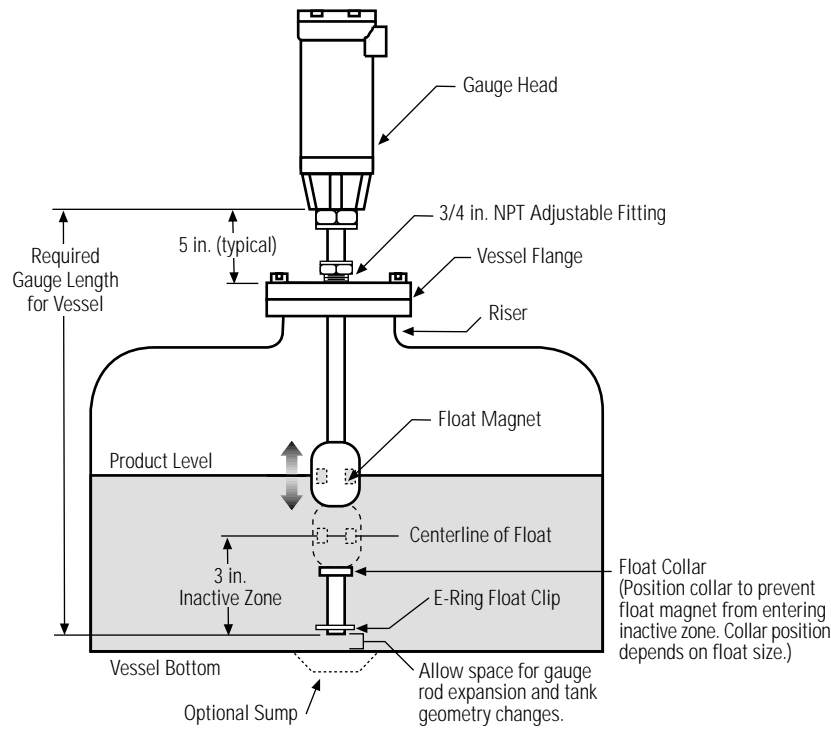

Figure 4.3 Flange Mounting

4.3 Threaded Mounting of a Gauge

In the case of a smaller tank, the gauge can be mounted directly in the tank, assuming proper wall thickness for sealing. Access must be available to mount the floats on the gauge from inside the tank, such as through a nearby larger access.

Floats are first removed from the gauge by removing the E-ring securing clip and/or steel collar. The end of the gauge is then inserted through the threaded opening and, by reaching from the other access, the floats and the float securing hardware are re-installed. The gauge is then lowered into the tank and secured at the proper position in the tank by tightening the adjustable Swagelok® type fitting. In most applications, the gauge should be raised off the bottom approximately one-half inch before the fitting is tightened. This will allow for expansion of the pipe due to temperature changes.

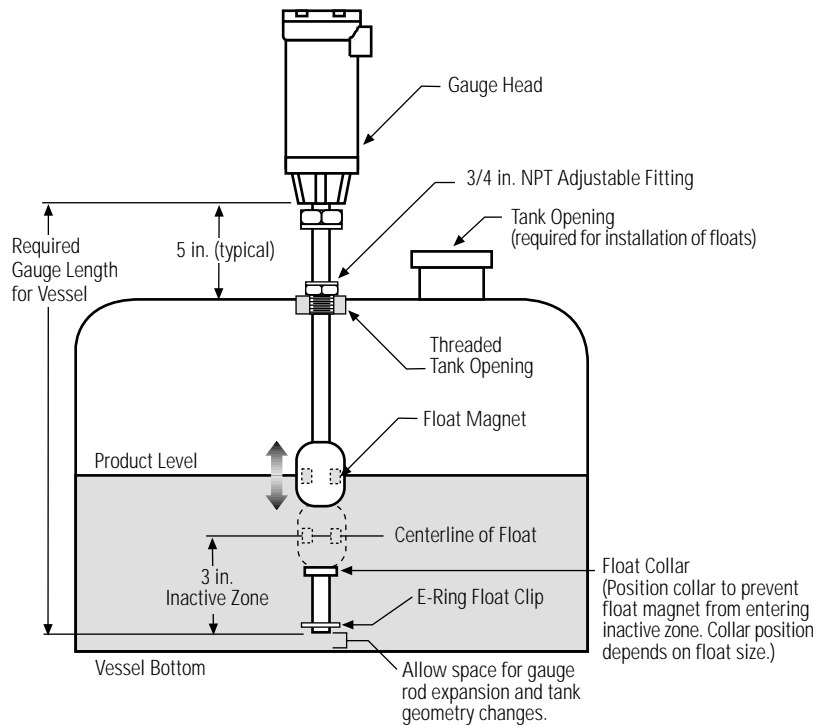

Figure 4.4 Threaded Nozzle Mounting

4.4 Sanitary (Tri-Clamp®) Mounting

In sanitary or clean-in-place applications, the gauge is mounted directly to the Tri-Clamp union previously installed on the tank. The clean-in-place style gauge uses a float retainer clip which allows for float removal during installation. The 3A sanitary gauge uses a welded float retainer and cannot be removed. This must be considered when specifying the style of Tri-Clamp union that will be required on the tank. Contact an MTS Applications Engineer for additional information.

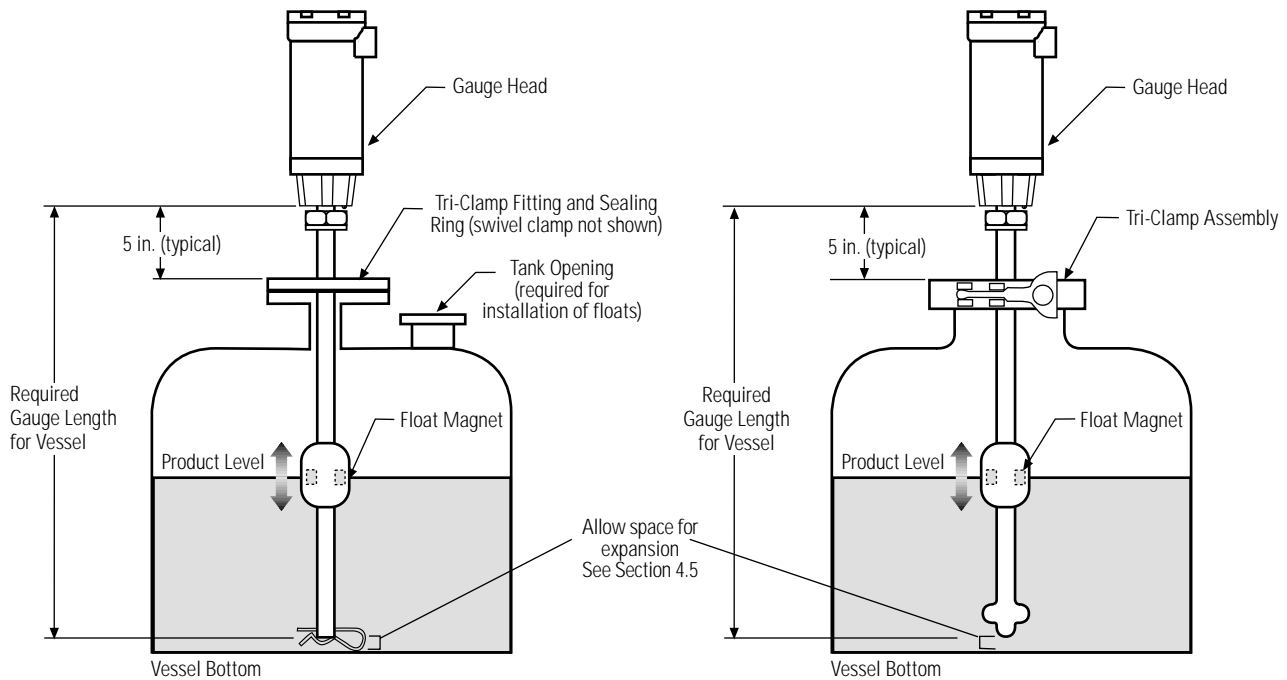

Figure 4.5 Tri-Clamp Mounting

4.5 Thermal Expansion Calculations

The following equation is used to determine the space that needs to be allotted for thermal expansion of the gauge sensing rod:

$$S = (TC) \times (L) \times (\Delta T)$$

S: is the allotted space in inches

TC: is the thermal coefficient of linear expansion, (TC for stainless steel = $8.9 \times 10^{-6}/^{\circ}\text{F}$, TC for Kynar = $6.3 \times 10^{-5}/^{\circ}\text{F}$)

L: is the length of the gauge in inches

ΔT : is $T_2 - T_1$ in $^{\circ}\text{F}$ (T_2 : maximum product temperature, T_1 : minimum product temperature)

4.6 LDF Long Gauge Installation

CAUTION

When assembling and installing the LDF Long Gauge be careful not to allow the flexible hose to kink or be coiled in less than 12" diameter.

It is recommended that assembly and mounting of this gauge not be done alone. To ensure proper and safe assembly of the LDF Long Gauge, a minimum of two (2) individuals are recommended. Gloves are also recommended.

1. With assistance, feed the flexible hose through the one inch NPT hole of the customer flange until the flange is positioned at the 2 foot long solid section of pipe. Insert the threaded portion of the adjustable fitting into the customer flange (apply pipe thread sealant if required). Be careful not to drop flange on flexible tube as damage may result to instrument.
2. Slide the product float onto the flexible pipe. See Figure 4.6.
3. Slide the interface float (optional) onto the flexible pipe with letters as shown facing the top of the pipe (see Figure 4.6). Do not drop the float(s) or allow them to free fall along the flexible pipe as damage may result.
4. Please follow warnings and handling instructions.

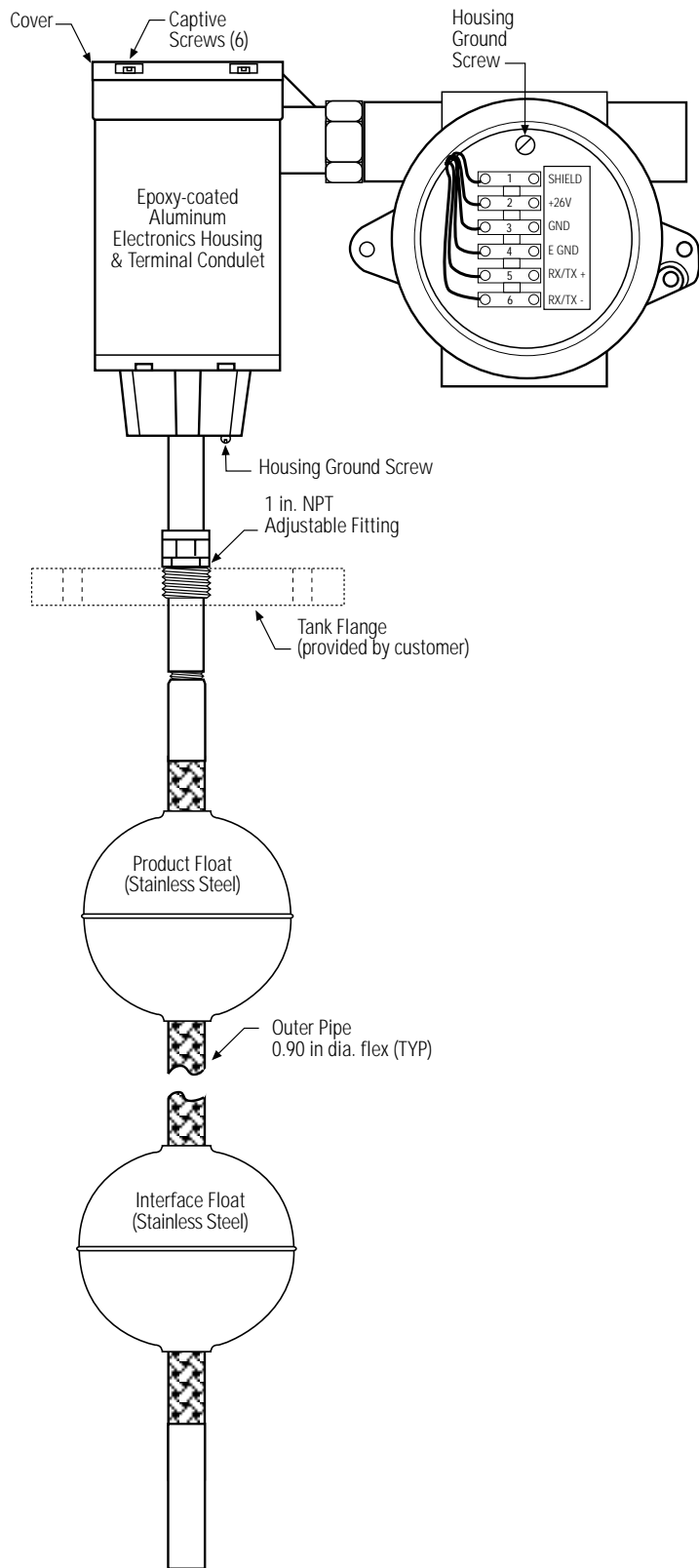

Figure 4.6 Flange and Float Installation

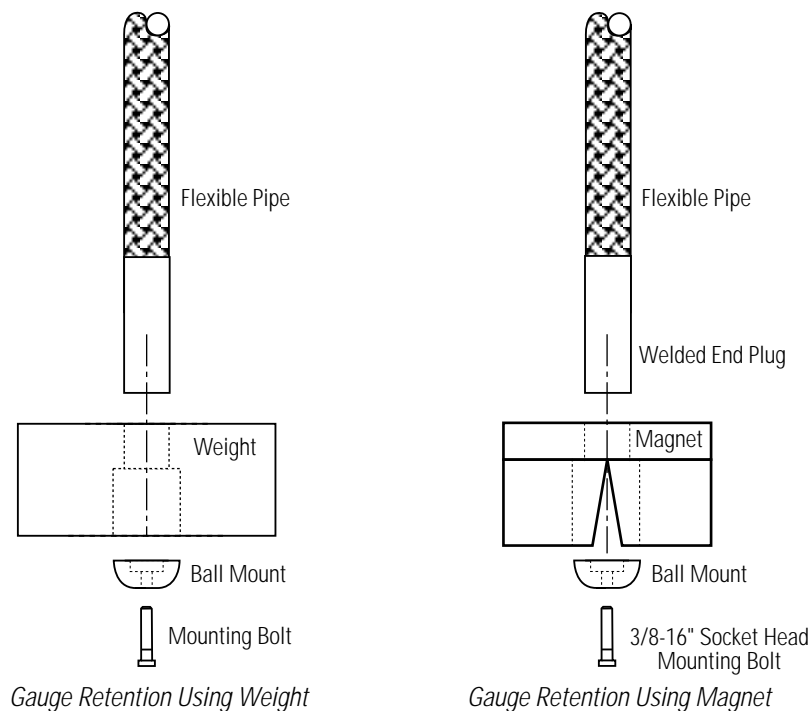

Figure 4.7 Bottom Fixing Hardware

4. Mount the weight or the magnet to the welded end plug section of the pipe (this is the bottom section of the pipe) using the supplied ball mount and mounting bolt. Securely tighten mounting bolt using 5/16 inch allen wrench. The ball mount can be reversed for applications with a sloped bottom tank. This method will allow the weight or magnet to swivel up to 15°. See Figure 4.7.
5. Slide the floats back down to the weight or magnet to prevent them from free falling during installation into the tank. Insert the flex pipe (with floats) through the tank riser pipe and lower the gauge/float assembly into the tank until it rests on the bottom. **DO NOT DROP OR DAMAGE THE PIPE.** Important: Avoid kinking or bending the flexible pipe in less than 1 foot radius or damage may result.
6. Secure the flange onto the tank riser pipe.
7. Pull the gauge upward to straighten the flexible pipe until the resistance of the weight or magnet is felt without raising the weight or magnet off the floor of the tank. Tighten the adjustable fitting to hold the gauge in place.
8. Terminate the field wire cables to the terminal block inside the conduit housing noting proper wire orientation. Reinstall conduit cover and properly tighten to maintain NEMA 4 rating.

5 FLOATS

For information on floats, please request a Float Specification document, MTS part number 550537. For float application information please contact an MTS Level Applications Engineer.

6 DDA CABLE REQUIREMENTS

The wiring connections for the DDA system are based on an EIA-485 distributed bus (network) as shown in figure 6.1. The network consists of the main trunk and individual tap connections to each DDA gauge. The main trunk and each network tap consist of four wires that provide both power and communications to each gauge on the network. The DDA network is approved as an intrinsically safe system when used with the zener safety barriers listed on MTS installation drawings #650511 and #650587. The approvals cover Class I, II, III, Division 1, Groups C, D, E, F and G hazardous locations.

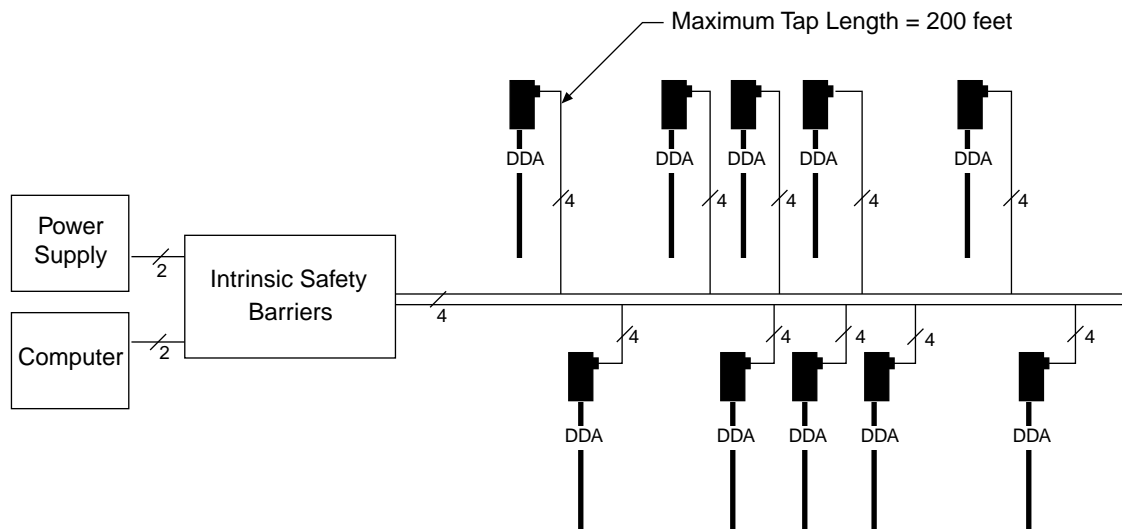

Figure 6.1 DDA Network

The use of safety barriers limit the amount of energy (current x volts) available to the DDA gauges on the network. To achieve low power operation, the DDA gauges operate in sleep mode until commanded by the host computer to wake up and perform level or temperature measurements. In sleep mode, each gauge on the network typically draws 1 milliamp of current. When a gauge is activated by the host, the typical current draw is 30 milliamps for the active gauge. The network, including the safety barriers must be able to support the required energy to allow all of the DDA gauges to work properly. The resistance of the barrier and the resistance of the cable then become the dominant factors in establishing the type and length of cables that can be used.

The capacitance of the cable also affects the network operation and must be considered when selecting cable for the network. The primary consideration is that the capacitance of the cable is an energy (voltage) storage element and affects the intrinsic safety aspects of the network. The secondary consideration is that the capacitance will attenuate the transmitted digital data. Since the communication baud rate is low (4800 bits per second), the voltage storage aspect of the cable is the dominant factor in determining cable types and lengths. In addition, each DDA gauge represents a fixed capacitance on the network that must be included in the total capacitance of the network. The capacitance at the power supply input terminals of each DDA gauge is 1600 picofarads and at the communication input terminals is 4000 picofarads. In all applications, the total capacitance of the cables and the total capacitance of all the DDA gauges on the network must be less than the allowable capacitance (C_a) specified for the safety barriers.

FMRC CONTROLLED DRAWING. NO CHANGES WITHOUT PRIOR FMRC APPROVAL

NON HAZARDOUS AREA

CLASS I II, III, DIVISION 1,
GROUPS C,D,E,F,G, HAZARDOUS AREA

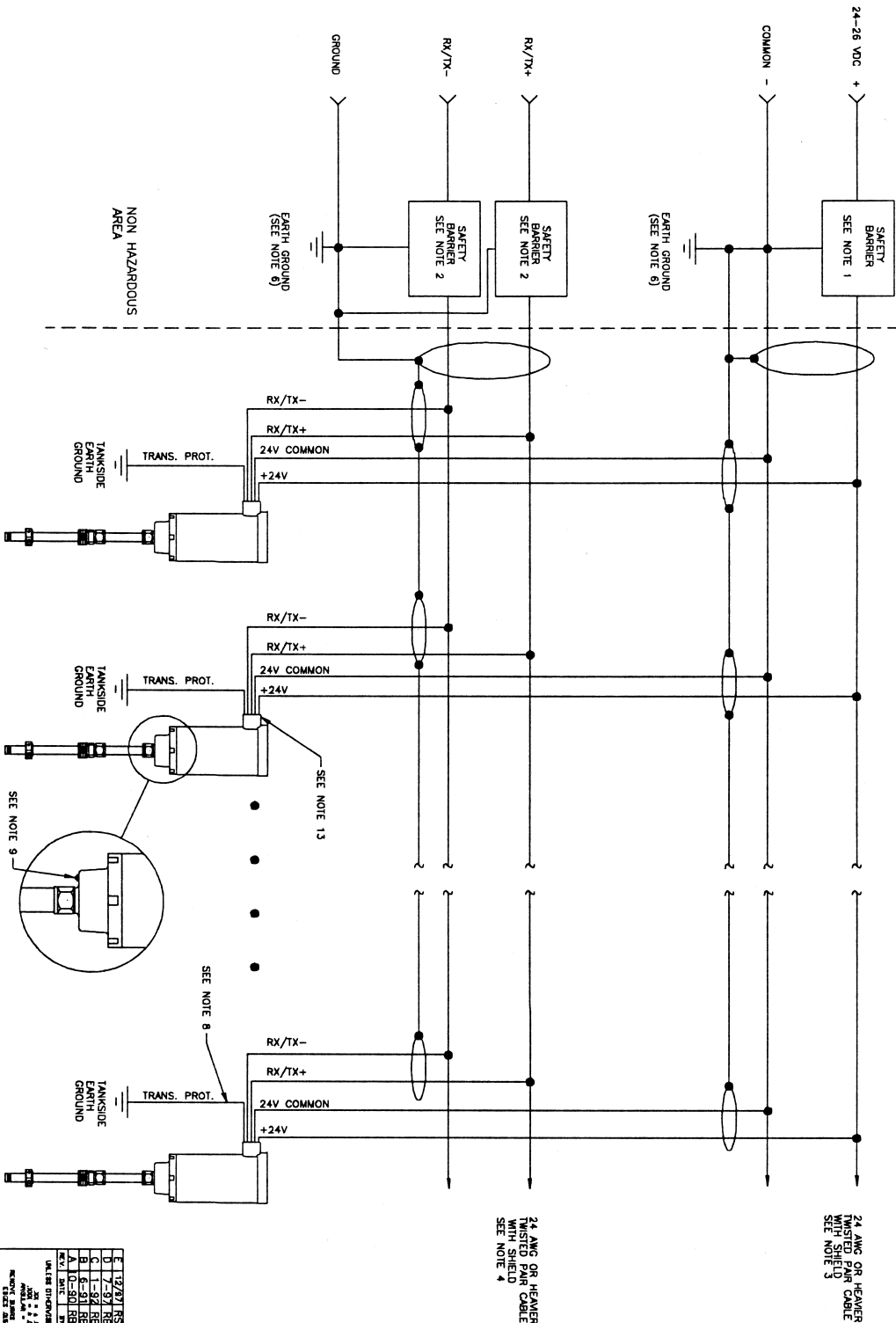

NOTES:

1. SEE PAGE 2 OF THIS DRAWING FOR FMRC APPROVED LIST OF SAFETY BARRIERS FOR THE DDA POWER SUPPLY CIRCUIT.
2. SEE PAGE 2 OF THIS DRAWING FOR FMRC APPROVED LIST OF SAFETY BARRIERS FOR THE DDA COMMUNICATIONS CIRCUIT.
3. POWER SUPPLY CABLE MUST BE 24 AWG OR HEAVIER, SHIELDED 50 FT PER FOOT CABLE TYPE AND LENGTH MUST BE SELECTED TO MEET MAXIMUM ALLOWABLE CAPACITANCE AND INDUCTANCE VALUES FOR SELECTED SAFETY BARRIER. SEE NOTE 5. CABLE SHIELD IS CONNECTED TO SYSTEM GROUND AT SAFETY BARRIER END ONLY. SEE INSTALLATION MANUAL FOR ADDITIONAL BARRIER END ONLY. SEE INSTALLATION MANUAL FOR ADDITIONAL COMMUNICATIONS CABLE MUST BE 24 AWG OR HEAVIER, SHIELDED TWISTED PAIR CABLE. CABLE CAPACITANCE MUST BE LESS THAN 24 PF PER FOOT. CABLE TYPE AND LENGTH MUST BE SELECTED TO MEET MAXIMUM ALLOWABLE CAPACITANCE AND INDUCTANCE VALUES FOR SELECTED SAFETY BARRIER. SEE NOTE 5. CABLE SHIELD IS CONNECTED TO SYSTEM GROUND AT SAFETY BARRIER END ONLY. SEE INSTALLATION MANUAL FOR ADDITIONAL COMMUNICATIONS CABLE INFORMATION.
5. THE INPUT CAPACITANCE OF EACH DDA GAUGE MUST BE INCLUDED IN THE TOTAL CAPACITANCE CONNECTED TO EACH SAFETY BARRIER FOR THE 24 VOLT COMMON SUPPLY (PER GAUGE). FOR ALL INSTALLATIONS: $C_{(barrier)} > C_{(cable)} + C_{(gauges)}$. FOR ALL INSTALLATIONS: $L_{(barrier)} > L_{(cable)}$.
6. THE WIRE CONNECTION BETWEEN EARTH GROUND AND THE SAFETY BARRIER GROUND TERMINAL MUST BE LESS THAN 1 INCH.
7. MAXIMUM APPROVED NUMBER OF DDA GAUGES FOR INTRINSICALLY SAFE WIRING NETWORKS IS 32. SEE OPERATION AND INSTALLATION MANUAL FOR SYSTEM CONFIGURATIONS AND RESTRICTIONS.
8. CONNECTION TO EARTH GROUND FOR TRANSIENT PROTECTION CIRCUITRY.
9. GROUND SCREW PROVIDED TO CONNECT GAUGE HOUSING TO EARTH GROUND.
10. ELECTRONIC EQUIPMENT CONNECTED TO ASSOCIATED APPARATUS MUST NOT USE OR GENERATE MORE THAN 250 VOLTS RMS.
11. CABLE SETS THAT ARE RUN TOGETHER MUST HAVE SUFFICIENT INSULATION TO WITHSTAND 250 VOLTS RMS BETWEEN SETS.
12. ALL WIRING MUST MEET THE REQUIREMENTS OF THE NEC AND LOCAL CODES.
13. DUST TIGHT SEAL AT CONDUIT ENTRY REQUIRED IN CLASS II OR CLASS III LOCATIONS.
14. INTRINSIC SAFETY BARRIERS USED FOR DDA POWER AND DDA COMMUNICATIONS CIRCUITS MUST BE OF THE SAME MANUFACTURER.

NO REVISIONS SHALL BE MADE WITHOUT NOTIFICATION TO APPROVAL AGENCIES(S)

REV	DATE	BY	DESCRIPTION
1	12/27/87	RSB	ISSUION SHEET 14 ON SHEET 2 REMOVE ITEMS C & F
2	7-97	RSB	ADDED NEW SAFETY BARRIERS TO NOTES 1 AND 2
3	1-84	RSB	ADDED NEW SAFETY BARRIERS TO NOTES 1 AND 2
4	1-84	RSB	ADDED NEW SAFETY BARRIERS TO NOTES 1 AND 2
5	1-84	RSB	ADDED NEW SAFETY BARRIERS TO NOTES 1 AND 2
6	1-84	RSB	ADDED NEW SAFETY BARRIERS TO NOTES 1 AND 2
7	1-84	RSB	ADDED NEW SAFETY BARRIERS TO NOTES 1 AND 2
8	1-84	RSB	ADDED NEW SAFETY BARRIERS TO NOTES 1 AND 2
9	1-84	RSB	ADDED NEW SAFETY BARRIERS TO NOTES 1 AND 2
10	1-84	RSB	ADDED NEW SAFETY BARRIERS TO NOTES 1 AND 2
11	1-84	RSB	ADDED NEW SAFETY BARRIERS TO NOTES 1 AND 2
12	1-84	RSB	ADDED NEW SAFETY BARRIERS TO NOTES 1 AND 2
13	1-84	RSB	ADDED NEW SAFETY BARRIERS TO NOTES 1 AND 2
14	1-84	RSB	ADDED NEW SAFETY BARRIERS TO NOTES 1 AND 2

MTS PROPRIETARY INFORMATION
 THE INFORMATION AND DESIGNS DISCLOSED HEREIN ARE THE
 PROPERTY OF MTS SYSTEMS CORPORATION AND ARE NOT TO BE
 REPRODUCED OR DISCLOSED IN ANY FORM EXCEPT AS GRANTED
 BY MTS SYSTEMS CORPORATION. THIS DISTRIBUTION
 OF DRAWINGS IS MADE BY MTS SYSTEMS CORPORATION AS A
 LEGITIMATELY IN PRIOR POSSESSION OF RECEIPT.

FMRC APPROVED SAFETY BARRIERS FOR DDA POWER
 SUPPLY CIRCUIT INCLUDE:

- A. STAHL TYPE 8901/31-280/165/80 Cext (max)=0.30uF
 Lext (max)=5.1mH
- B. MTL TYPE 728+
 Cext (max)=0.13uF Lext (max)=4.2mH
- D. STAHL TYPE 9001/01-280-165-10 Cext (max)=0.43uF
 Lext (max)=5.4mH
- E. CROUSE HINDS TYPE SB19140M2410 Cext (max)=0.43uF
 Lext (max)=6.96mH
- F. CROUSE HINDS TYPE SB49140M2410 Cext (max)=0.43uF
 Lext (max)=6.96mH (DUAL CHANNEL TYPE)
- G. STAHL TYPE 9002/11-280-186-00 Cext (max)=0.39uF
 Lext (max)=16.4mH (DUAL CHANNEL TYPE)

FMRC APPROVED SAFETY BARRIERS FOR DDA COMMUNICATIONS
 CIRCUIT INCLUDE:

- A. STAHL TYPE 8901/31-086/150/70 Cext (max)=10.8uF
 Lext (max)=4.2mH
- B. MTL TYPE 710+
 Cext (max)=3.0uF Lext (max)=0.95mH
- D. STAHL TYPE 9001/01-086-150-10 Cext (max)=17.6uF
 Lext (max)=6.7mH
- E. CROUSE HINDS TYPE SB19140M0710 Cext (max)=3.0uF
 Lext (max)=0.95mH
- G. STAHL TYPE 9002/22-093-300-00 Cext (max)=11.4uF
 Lext (max)=6.5mH (DUAL CHANNEL TYPE)



SYSTEMS CORPORATION
 SENSORS DIVISION
 RESEARCH TRIANGLE PARK, NORTH CAROLINA 27709

TITLE FMRC WIRING DIAGRAM
 INTRINSICALLY SAFE
 DDA LIQUID LEVEL

DRAWN	DATE
R. BARR	8-7-97
DOCUMENT OWNER	
K. PETERSON	
PRODUCT LINE	
DDA	
SCALE	DRAWING SIZE
1:1	B
SHEET 2	OF 2

DWG NO. 650511 REV E

CSA CONTROLLED DRAWING. NO CHANGES WITHOUT PRIOR CSA APPROVAL

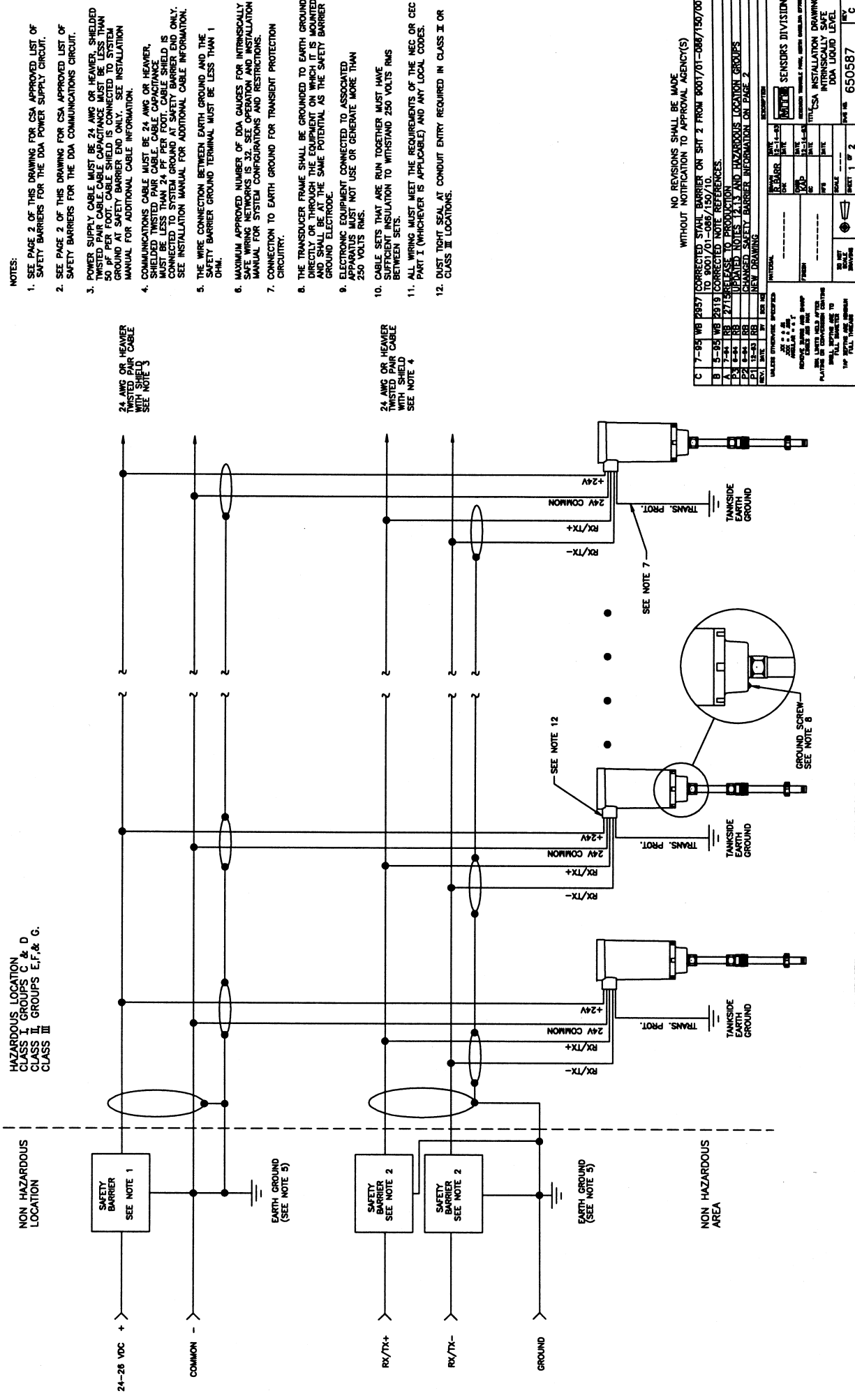

- NOTES:
1. SEE PAGE 2 OF THIS DRAWING FOR CSA APPROVED LIST OF SAFETY BARRIERS FOR THE DDA POWER SUPPLY CIRCUIT.
 2. SEE PAGE 2 OF THIS DRAWING FOR CSA APPROVED LIST OF SAFETY BARRIERS FOR THE DDA COMMUNICATIONS CIRCUIT.
 3. POWER SUPPLY CABLE MUST BE 24 AWG OR HEAVIER, SHIELDED TWISTED PAIR CABLE. CABLE CAPACITANCE MUST BE LESS THAN 50 pF PER FOOT. CABLE SHIELD IS CONNECTED TO SYSTEM GROUND AT SAFETY BARRIER END ONLY. SEE INSTALLATION MANUAL FOR ADDITIONAL CABLE INFORMATION.
 4. COMMUNICATIONS CABLE MUST BE 24 AWG OR HEAVIER, SHIELDED TWISTED PAIR CABLE. CABLE CAPACITANCE MUST BE LESS THAN 24 pF PER FOOT. CABLE SHIELD IS CONNECTED TO SYSTEM GROUND AT SAFETY BARRIER END ONLY. SEE INSTALLATION MANUAL FOR ADDITIONAL CABLE INFORMATION.
 5. THE WIRE CONNECTION BETWEEN EARTH GROUND AND THE SAFETY BARRIER GROUND TERMINAL MUST BE LESS THAN 1 OHM.
 6. MAXIMUM APPROVED NUMBER OF DDA GAUGES FOR INTRINSICALLY SAFE DEVICES IS 2. SEE SECTION 5.1 OF THE IEC 60079-10 MANUAL FOR SYSTEM CONFIGURATIONS AND RESTRICTIONS.
 7. CONNECTION TO EARTH GROUND FOR TRANSIENT PROTECTION CIRCUITRY.
 8. THE TRANSDUCER FRAME SHALL BE GROUND TO EARTH GROUND DIRECTLY OR THROUGH THE EQUIPMENT ON WHICH IT IS MOUNTED AND SHALL BE AT THE SAME POTENTIAL AS THE SAFETY BARRIER GROUND ELECTRODE.
 9. ELECTRONIC EQUIPMENT CONNECTED TO ASSOCIATED APPARATUS MUST NOT USE OR GENERATE MORE THAN 250 VOLTS RMS.
 10. CABLE SETS THAT ARE RUN TOGETHER MUST HAVE SUFFICIENT INSULATION TO WITHSTAND 250 VOLTS RMS BETWEEN SETS.
 11. ALL WIRING MUST MEET THE REQUIREMENTS OF THE NEC OR CEC PART I (WHICHEVER IS APPLICABLE) AND ANY LOCAL CODES.
 12. DUST TIGHT SEAL AT CONDUIT ENTRY REQUIRED IN CLASS II OR CLASS III LOCATIONS.

NO REVISIONS SHALL BE MADE WITHOUT NOTIFICATION TO APPROVAL AGENCY(S)

TO 9007/01-086/150/700

FROM 9007/01-086/150/700

DATE 10/15/10

BY [Signature]

DESCRIPTION: CORRECTED NOTE REFERENCES

REVISIONS:

REV.	DATE	BY	DESCRIPTION
1	10/15/10	[Signature]	ISSUED FOR CONSTRUCTION
2	10/15/10	[Signature]	ISSUED FOR CONSTRUCTION
3	10/15/10	[Signature]	ISSUED FOR CONSTRUCTION
4	10/15/10	[Signature]	ISSUED FOR CONSTRUCTION
5	10/15/10	[Signature]	ISSUED FOR CONSTRUCTION
6	10/15/10	[Signature]	ISSUED FOR CONSTRUCTION
7	10/15/10	[Signature]	ISSUED FOR CONSTRUCTION
8	10/15/10	[Signature]	ISSUED FOR CONSTRUCTION
9	10/15/10	[Signature]	ISSUED FOR CONSTRUCTION
10	10/15/10	[Signature]	ISSUED FOR CONSTRUCTION
11	10/15/10	[Signature]	ISSUED FOR CONSTRUCTION
12	10/15/10	[Signature]	ISSUED FOR CONSTRUCTION

SCALE: 1" = 2'

FIG. NO. 650587

REV. C

MTS PROPRIETARY INFORMATION
 THE INFORMATION AND DESIGN(S) DESCRIBED HEREIN ARE THE
 PROPERTY OF MTS SYSTEMS CORPORATION. THIS INFORMATION
 IS NOT TO BE REPRODUCED OR TRANSMITTED IN ANY FORM OR BY ANY
 MEANS, ELECTRONIC OR MECHANICAL, INCLUDING PHOTOCOPYING,
 RECORDING, OR BY ANY INFORMATION STORAGE AND RETRIEVAL
 SYSTEMS, WITHOUT THE WRITTEN PERMISSION OF MTS SYSTEMS
 CORPORATION.

CSA APPROVED SAFETY BARRIERS FOR DDA POWER
 SUPPLY CIRCUIT INCLUDE:

- A. STAHL TYPE 8901/31-280/165/80
- B. MTL TYPE 728+
- C. PEPPERL & FUCHS TYPE Z428/EX
- D. STAHL TYPE 9001/01-280/165/10
- E. CROUSE HINDS TYPE SB19140M2410
- F. CROUSE HINDS TYPE SB49140M2410
 (DUAL CHANNEL TYPE).

CSA APPROVED SAFETY BARRIERS FOR DDA COMMUNICATIONS
 CIRCUIT INCLUDE:

- A. STAHL TYPE 8901/31-086/150/70
- B. MTL TYPE 710+
- C. PEPPERL & FUCHS TYPE Z111/EX
- D. STAHL TYPE 9001/01-086/150/10
- E. CROUSE HINDS TYPE SB49140M1250
 (DUAL CHANNEL TYPE).

UNLESS OTHERWISE SPECIFIED:

XX = ± .01
 XXX = ± .005
 ANGULAR = ± 1'
 REMOVE BURRS AND SHARP
 EDGES .015 MAX
 DIM. LIMITS HELD AFTER
 PLATING OR CONVERSION COATING
 DRILL DEPTHS ARE TO
 FULL DIAMETER
 TAP DEPTHS ARE MINIMUM
 FULL THREADS

MATERIAL		FINISH		DRAWN		DATE		TITLE	
				R. BARR		12-14-93		SYSTEMS CORPORATION	
				DOCUMENT DIVNER				SENSORS DIVISION	
				K. PETERSON				RESEARCH TRIANGLE PARK, NORTH CAROLINA 27709	
				PRODUCT LINE				DDA	
				SCALE DRAWING SIZE				DDA	
				1:1				TITLE	
				SHEET		2 OF 2		CSA INSTALLATION DRAWING	
				SCALE				INTRINSICALLY SAFE DDA	
				DRAWING				LIQUID LEVEL	
				DD NOT				DWG NO. 650587	
				SCALE				REV C	
				DRAWING					

THIS DRAWING IS THE PROPERTY OF MTS. IT IS TO BE USED ONLY FOR THE PROJECT AND SITE SPECIFICALLY IDENTIFIED IN THE TITLE. IT IS NOT TO BE REPRODUCED OR COPIED IN ANY MANNER WITHOUT THE WRITTEN PERMISSION OF MTS.

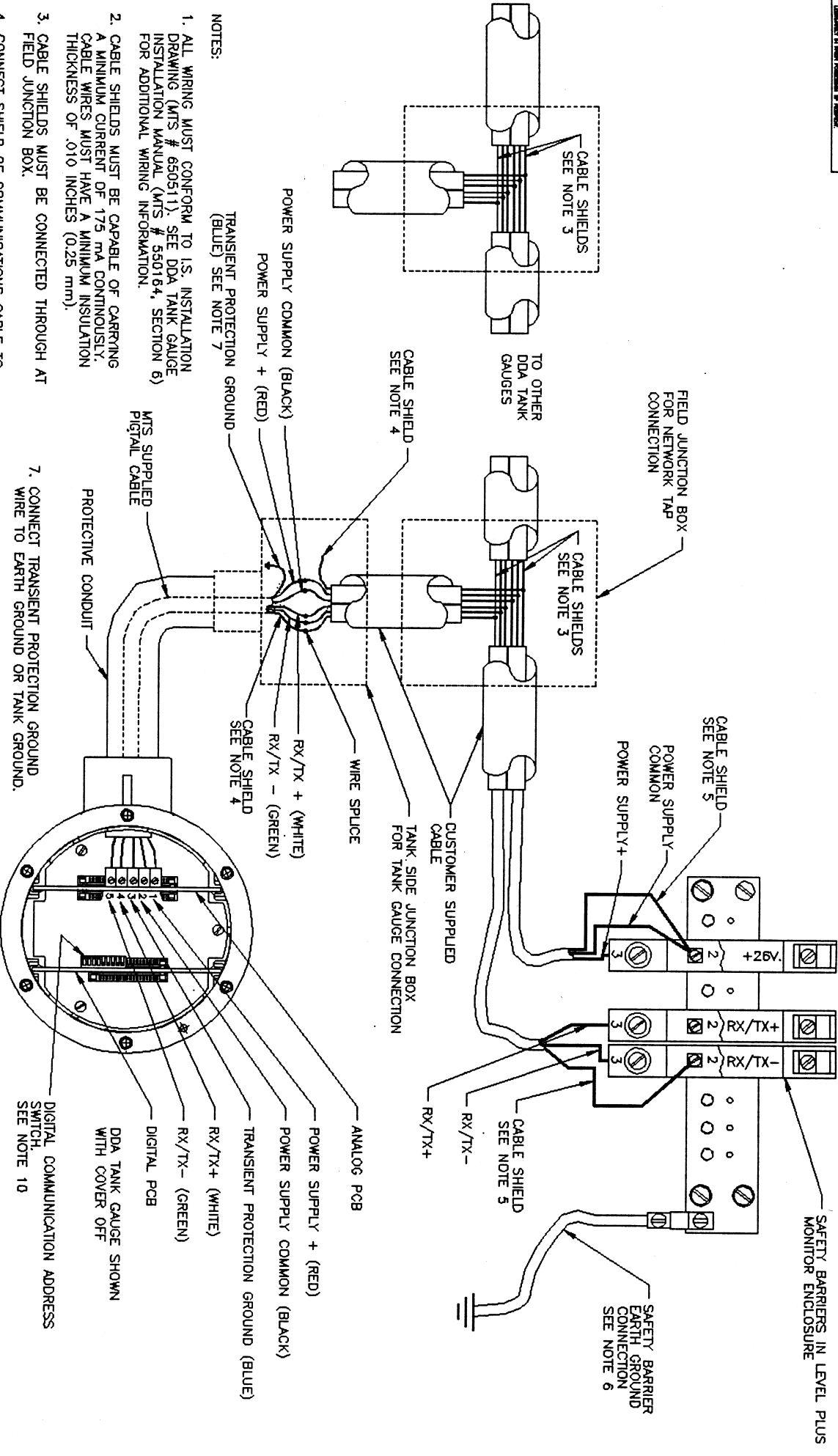

- NOTES:
1. ALL WIRING MUST CONFORM TO I.S. INSTALLATION DRAWING (MTS # 650511). SEE DDA TANK GAUGE INSTALLATION MANUAL (MTS # 550164, SECTION 6) FOR ADDITIONAL WIRING INFORMATION.
 2. CABLE SHIELDS MUST BE CAPABLE OF CARRYING A MINIMUM CURRENT OF 175 MA CONTINUOUSLY. CABLE WIRES MUST HAVE A MINIMUM INSULATION THICKNESS OF .010 INCHES (0.25 mm).
 3. CABLE SHIELDS MUST BE CONNECTED THROUGH AT FIELD JUNCTION BOX.
 4. CONNECT SHIELD OF COMMUNICATIONS CABLE TO SHIELD OF DDA TANK GAUGE PIGTAIL AT TANKSIDE JUNCTION BOX. DO NOT CONNECT SHIELD OF POWER SUPPLY CABLE AT TANKSIDE JUNCTION BOX.
 5. CONNECT CABLE SHIELDS TO EARTH GROUND AT SAFETY BARRIER END ONLY. CONNECT TO TERMINAL # 2 OF SAFETY BARRIERS AS SHOWN.
 6. THE SAFETY BARRIER EARTH GROUND CONNECTION MUST BE CONNECTED AT ALL TIMES. IT MUST BE 12 AWG WIRE (OR LARGER) AND MEASURE LESS THAN 1 OHM TO DEDICATED EARTH GROUND (SEPERATE FROM AC POWER GROUND).
 7. CONNECT TRANSIENT PROTECTION GROUND WIRE TO EARTH GROUND OR TANK GROUND.
 8. THE GROUND SCREW ON TANK GAUGE FLANGE TO MAY BE USED TO CONNECT GAUGE HOUSING TO EARTH GROUND OR TANK GROUND.
 9. DISTANCE FROM FIELD JUNCTION BOX(ES) TO TANKSIDE JUNCTION BOX(ES) NOT TO EXCEED 200 FEET.
 10. USER MUST SET COMMUNICATION ADDRESS SWITCH. SEE DDA TANK GAUGE MANUAL # 550164.

TO OTHER DDA TANK GAUGES

FIELD JUNCTION BOX FOR NETWORK TAP CONNECTION

CABLE SHIELDS SEE NOTE 3

CABLE SHIELD SEE NOTE 4

POWER SUPPLY COMMON (BLACK)

POWER SUPPLY + (RED)

TRANSIENT PROTECTION GROUND (BLUE) SEE NOTE 7

MTS SUPPLIED PIGTAIL CABLE

PROTECTIVE CONDUIT

WIRE SPLICE

RX/TX+ (WHITE)

RX/TX- (GREEN)

CABLE SHIELD SEE NOTE 4

CUSTOMER SUPPLIED CABLE

TANK SIDE JUNCTION BOX FOR TANK GAUGE CONNECTION

POWER SUPPLY COMMON

POWER SUPPLY+

RX/TX+

RX/TX-

CABLE SHIELD SEE NOTE 5

SAFETY BARRIERS IN LEVEL PLUS MONITOR ENCLOSURE

SAFETY BARRIER EARTH GROUND CONNECTION SEE NOTE 6

ANALOG PCB

POWER SUPPLY + (RED)

POWER SUPPLY COMMON (BLACK)

TRANSIENT PROTECTION GROUND (BLUE)

RX/TX+ (WHITE)

RX/TX- (GREEN)

DIGITAL PCB

DDA TANK GAUGE SHOWN WITH COVER OFF

DIGITAL COMMUNICATION ADDRESS SWITCH. SEE NOTE 10

REV. A	DATE 4/93	BY RB	ECO # 2891	DESCRIPTION	RELEASE TO PRODUCTION
UNLESS OTHERWISE SPECIFIED					
DIMENSIONS ARE IN INCHES UNLESS OTHERWISE SPECIFIED					
TYPICAL DIMENSIONS ARE IN INCHES UNLESS OTHERWISE SPECIFIED					
DO NOT SCALE DRAWING					
SHEET 1 OF 1					
MTS SYSTEMS CORPORATION SENSORS DIVISION RESEARCH TRIANGLE PARK, NORTH CAROLINA 27709			TITLE FIELD WIRING LEVEL PLUS DDA MONITOR		
DRAWING NO. 650567			REV A		

CAUTION

For the power supply circuit:

$C_a (\text{barrier}) > C (\text{cable}) + C (\text{gauges})$ where $C (\text{gauge}) = 1600 \text{ picofarads per gauge}$

For the communication circuit:

$C_a (\text{barrier}) > C (\text{cable}) + C (\text{gauges})$ where $C (\text{gauge}) = 4000 \text{ picofarads per gauge}$

The inductance of the cable similarly affects the intrinsic safety of the DDA system and must be considered when selecting cable for the network. The only consideration is that the inductance of the cable is an energy storage element and adversely affects the intrinsic safety of the network. The DDA gauge has a zero inductance value associated with the power supply and communications input terminals. The only inductance associated with the network is then from the cables. In all applications, to maintain intrinsic safety, the total inductance of the cables must be less than the allowable inductance (L_a) specified for the selected safety barriers.

CAUTION

For the power supply circuit:

$L_a (\text{barrier}) > L (\text{cable})$

For the communication circuit:

$L_a (\text{barrier}) > L (\text{cable})$

All cable selections must meet the requirements as specified in the installation drawings #650511 and #650587, notes 3 and 4. The power supply cable must be 24 AWG (American Wire Gauge) or heavier, shielded twisted pair with a capacitance of 50 picofarads per foot or less. The communication cable must be 24 AWG or heavier, shielded twisted pair with a capacitance of 24 picofarads per foot or less.

Since the resistance of the cable is the dominant factor in determining the maximum cable length of the network, heavier gauge cables will allow longer cable runs. This is true because heavier gauge cables inherently have lower resistance. For example, the resistance of typical 22 AWG cable is 15 ohms per 1000 feet of cable where as 18 AWG cable is 6 ohms per 1000 feet of cable. Both the power supply cable and the communications cable should be selected to be the same size (AWG). See section 6.2 in this manual for recommended cable types.

The graphs in figures 6.2 to 6.4 can be used to determine the maximum cable lengths allowed for any distributed bus type DDA network. Once the number of gauges on the network, the cable type, the safety barrier type, and the system power supply voltage have been selected, these graphs show the maximum cable lengths that can be used. The maximum cable lengths are associated with the main trunk length only. The tap connections can be ignored in the trunk cable length calculations and are limited to a maximum length of 200 feet in all applications. Note that the capacitance of the taps must still be considered in the total capacitance of the network.

The barrier type also affects the maximum length of the cable. This is due to the fact that each of the barrier types have different series resistance associated with them. DDA systems that use the safety barriers with higher series resistance will consequently have shorter maximum cable lengths and/or fewer number of gauges allowed on the network. The safety barrier selection is based on the power supply circuit safety barrier only. The resistance of the communication circuit safety barrier is non-critical and does not need to be considered when determining cable type or maximum cable length.

The cable selection graphs are based on the resistance factors of the DDA system and do not account for capacitance or inductance aspects. In many cases, maximum cable length may be limited by the total capacitance or total inductance of the network so that the intrinsic safety of the network is maintained. As mentioned above, the capacitance and inductance of the network taps must be considered in the total capacitance and total inductance of the network.

As stated earlier, to maintain the intrinsic safety of the DDA system:

For the power supply circuit:

$C_a \text{ (barrier)} > C \text{ (cable)} + C \text{ (gauges)}$ where $C \text{ (gauge)} = 1600$ picofarads per gauge and $L_a \text{ (barrier)} > L \text{ (cable)}$

For the communication circuit:

$C_a \text{ (barrier)} > C \text{ (cable)} + C \text{ (gauges)}$ where $C \text{ (gauge)} = 4000$ picofarads per gauge, and $L_a \text{ (barrier)} > L \text{ (cable)}$

The cable selection graphs indicate possible cable lengths up to 8000 feet in certain applications. Cable lengths of this maximum distance can only be achieved if both the cable selection (for the communication circuit) and the communication driver chip (from the host interface) meet the requirements as defined by the EIA-485 standard. Per the EIA-485 standard, cable (for the communication circuit) must have a nominal impedance of 120 ohms and be of low capacitance type (less than 20 picofarads per foot). In addition, any communication driver chip on the network must be able to drive 32 unit loads. This EIA-485 requirement does not apply to the cable selection for the power supply circuit.

6.1 Cable Selection Graphs

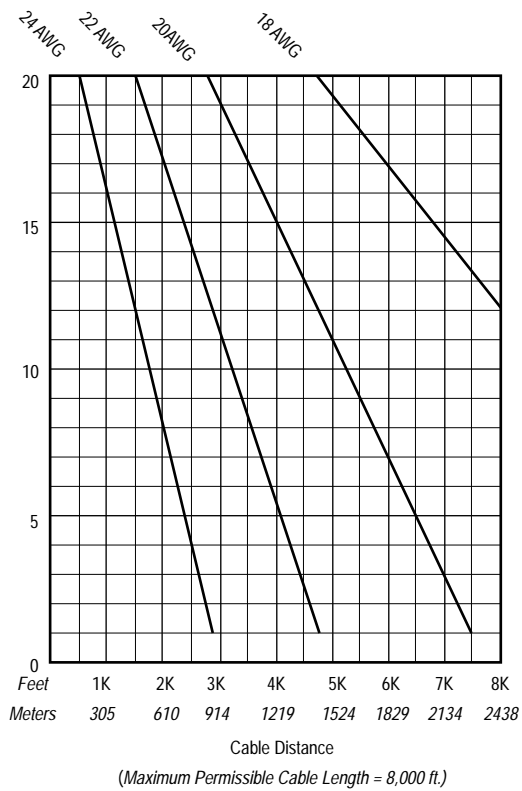
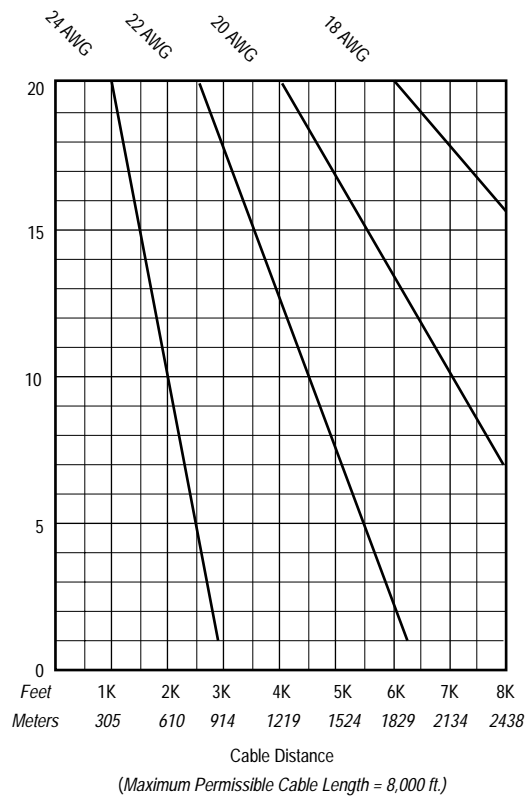

Figure 6.2

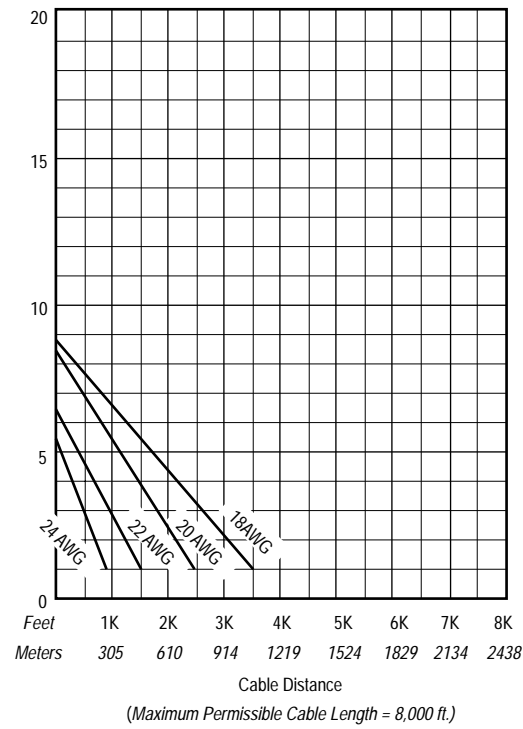
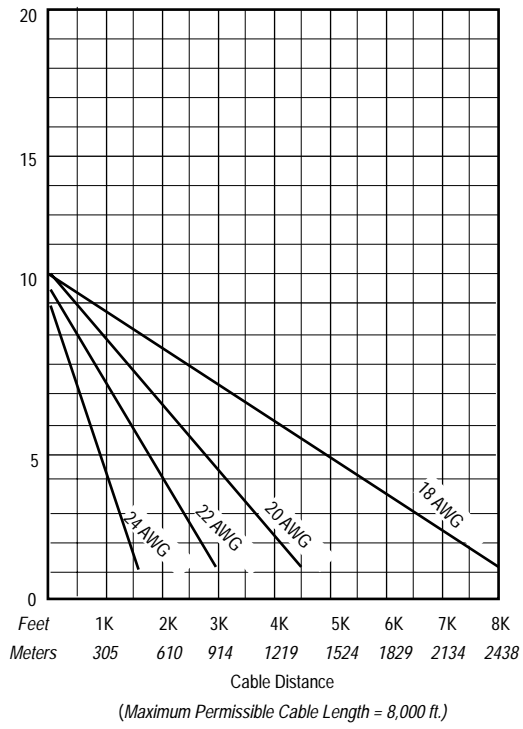

Figure 6.3

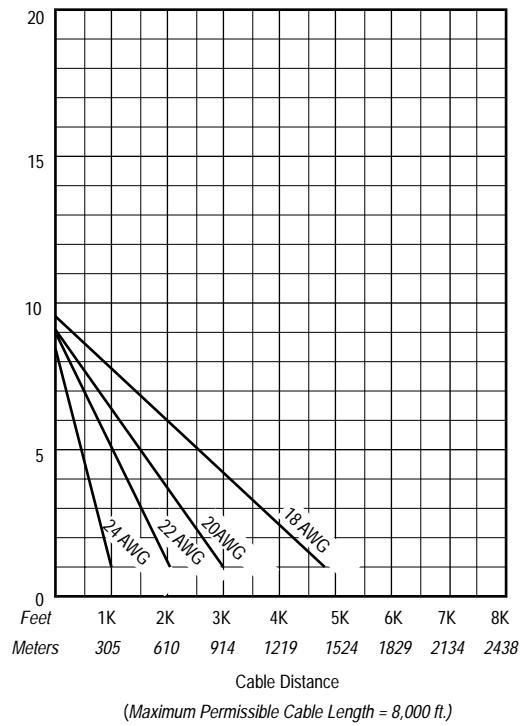
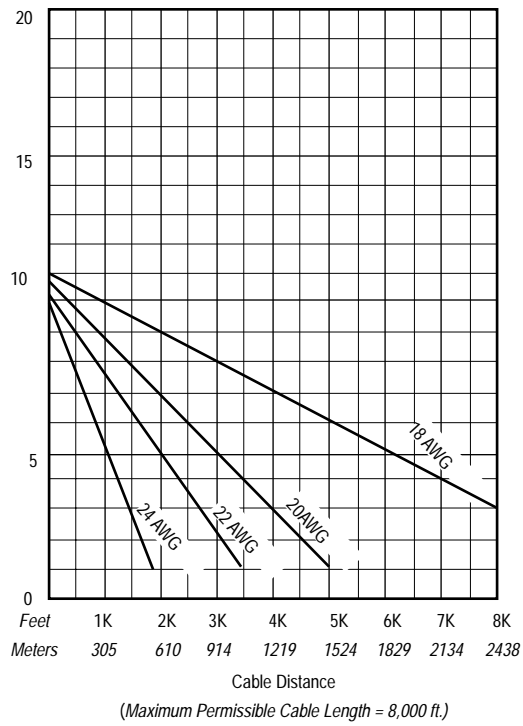

Figure 6.4

6.2 Recommended Cable Types

The following section lists recommended cable types for both the DDA power supply circuit and the DDA communication circuit. The lists are not inclusive of all cable types and cable manufacturers and should serve only as a guideline when choosing cables. Other cable types can be selected that meet the requirements of the DDA system.

Recommended cable types for the DDA power supply circuit (individual cable pair):

General requirements:

- shielded, twisted pair
- 50 picofarads/foot or less. See note below.
- minimum .010 in. (0.25 mm) insulation thickness

NOTE

For the power supply circuit, the return conductor is connected to the shield at the safety barrier ground terminal. When determining the capacitance of cable for the power supply circuit, use the manufacturer's capacitance specifications shown for one conductor and the other conductor connected to the shield.

WIRE SIZE (AWG)	CAPACITANCE (Pf/foot)	MANUFACTURER	CABLE #	NOTES	
16	40	ALPHA	2471	(16 AWG ok)	
18	44	BELDEN	8760		
18	49	BELDEN	9460	(16 AWG ok)	
16	49	CAROL	C2536		
18	44	CAROL	C2521		
18	43	DEKORON	1T52-8820T		
20	49	BELDEN	8762		
20	49	BELDEN	9464		
20	40	CAROL	C2519		
20	45	CAROL	C2520		
20	46	MANHATTAN	M39047		
20	42	DEKORON	1T52-0810T		
22	16	ALPHA	6072		(extra wire pair)
22	47	BELDEN	8761		
22	47	BELDEN	9461		
22	36	CAROL	C2518		
22	47	CAROL	C2514		
22	38	DEKORON	1T52-2810T		(.020" insulation)
22	38	DEKORON	1T52-2810T		
24	23	BELDEN	9841		
24	42	BELDEN	8641		
24	42	CAROL	C2513		
24	40	DEKORON	1T52-A800T		

Recommended cable types for the DDA communication circuit (individual cable pair):

General requirements:

- shielded, twisted pair
- 24 picofarads/foot or less, see note below
- nominal impedance range - 100 to 150 ohms
- minimum .010 inch (0.25 mm) insulation thickness

NOTE

For the communication circuit, the shield is terminated independently at the safety barrier ground terminal. When determining the capacitance of cable for the communication circuit, use the manufacturer's capacitance specifications shown for conductor to conductor.

WIRE SIZE (AWG)	CAPACITANCE (Pf/foot)	MANUFACTURER	CABLE #	NOTES
16	21	ALPHA	2471	(16 AWG ok)
18	24	BELDEN	8760	
18	16	BELDEN	9450	(twin axial)
16	11	CAROL	C8013	(16 AWG ok, twin axial)
18	24	CAROL	C2521	
18	24	DEKORON	1T52-8820T	
20	22	BELDEN	83393	
20	16	BELDEN	9207	(twin axial)
20	22	CAROL	C2519	
20	16	CAROL	C8010	(twin axial)
20	16	MANHATTAN	M4270	(twin axial)
20	23	DEKORON	T52-0810T	
22	9	ALPHA	6072	(extra wire pair)
22	22	BELDEN	83394	
22	20	BELDEN	9999	(twin axial)
22	20	CAROL	C2518	
22	9	CAROL	C8014	(twin axial)
22	9	MANHATTAN	M39240	
22	21	DEKORON	1T52-2810T	(.020" insulation)
24	13	BELDEN	9841	
24	22	BELDEN	8641	
24	3	CAROL	C2513	
24	22	DEKORON	1T52-A800T	

Recommended cable types for the DDA power supply and communication circuits (multiple cable pair - 2 pairs):

General requirements:

- individually shielded, twisted pair, 2 pairs
- 24 picofarads/foot or less, see note below
- minimum .010 inch (0.25 mm) insulation thickness

NOTE
The capacitance figures in this chart include information for both DDA wiring circuits. The figure on the left is for the communication circuit where the capacitance of the cable is measured from conductor to conductor. The figure on the right is for the power supply circuit where the capacitance of the cable is measured from one conductor and the other conductor connected to the shield.

WIRE SIZE (AWG)	CAPACITANCE (Pf/foot)	MANUFACTURER	CABLE #	NOTES
18	24/43	DEKORON	1T74-80222	
20	22/44	ALPHA	2467C	(2 extra wire pairs)
20	3/44	DEKORON	1T74-00212	
22	9/17	BELDEN	9688	
22	16/28	MANHATTAN	M3490	
22	21/38	DEKORON	1T74-20212	
24	13/22	ALPHA	6073	(extra wire pair)
24	13/22	BELDEN	8162	
24	13/23	BELDEN	9729	
24	13/23	CAROL	C0924	
24	13/23	MANHATTAN	M39249	
24	13/22	MANHATTAN	M3475	
24	22/40	DEKORON	1T74-A0202	

NOTE
Most cable manufacturers do not list inductance properties for cables. Where the inductance properties are unavailable, ISA RP12.6 (Installation of Intrinsically Safe Instrument Systems in Class I Hazardous Locations) recommends the use of 0.2 μ H (micro henries) per foot as a value for cable inductance.

6.3 How To Select Cables (for Intrinsically Safe DDA Networks)

The steps and criteria used for selecting cable for the DDA network are outlined below. This procedure allows for easy cable selections that meet the requirements of an intrinsically safe DDA network.

1. Determine the number of DDA gauges that will be connected to the network. The maximum number of gauges per network is 20 for intrinsically safe applications. Consult factory for maximum number of gauges for non-intrinsically safe applications.
2. Determine the type (brand) of safety barrier that will be used for the power supply circuit. Currently three types of barriers are approved for the DDA network as follows:

- A. STAHL 8901/31-280/165/80 [maximum resistance (end-to-end) = 201 ohms]
- B. MTL 728 [maximum resistance (end-to-end) = 340 ohms]
- C. PEPPERL & FUCHS Z428/EX [maximum resistance (end-to-end) = 327 ohms]

As stated earlier, the safety barrier with the lowest end-to-end resistance will allow the most gauges on the network and/or the longest cable lengths. This can be verified by reviewing the cable selection charts for each type of barrier. Safety barrier types (brands) should not be mixed for the power supply circuit and the communication circuit. If STAHL is selected for the power supply circuit, then STAHL should be used for the communication circuit. See installation drawings #650511 and #650587 for safety barrier types usable with the communication circuit.

3. Determine the power supply voltage that will be used for the DDA network. The available choices are limited to 24 volts and 26 volts (DC). As indicated by the cable selection graphs, the higher power supply voltage will allow more DDA gauges on the network and/or longer cable lengths. See section 7 of this manual for additional information about power supplies for DDA networks.
4. Determine the maximum proposed cable length that will be required for the network trunk for the particular application. Tap connections between the main network trunk and each DDA gauge are limited to 200 feet. Absolute maximum trunk length is limited to 8000 feet.
5. Using the respective cable selection chart for the safety barrier type and power supply voltage selected above, determine the cable gauge (AWG size) required for the number of gauges and cable length information determined above.

NOTE

If a suitable cable gauge cannot be found from the charts, then the number of DDA gauges must be reduced or the cable length must be reduced. The safety barrier type or the power supply voltage may also be changed depending on the particular situation.

6. Select cables from the recommended cable lists (or other source) that meet the gauge and capacitance specifications for the power supply circuit and the communications circuit. The cable capacitance specifications must meet the requirements as shown in the MTS installation drawing #650511 (50 picofarads or less for the power supply circuit and 24 picofarads or less for the communication circuit).

7. Calculate the maximum network capacitance for each circuit (power supply and communications). Include the capacitance of the cable and the capacitance of each DDA gauge. The capacitance of each network tap connection must also be included in the total cable capacitance. Verify that the following equations are met to insure the intrinsic safety of the system:

For the power supply circuit:

$C_a \text{ (barrier)} > C \text{ (cable)} + C \text{ (gauges)}$ where $C \text{ (gauge)} = 1600 \text{ picofarads per gauge}$

For the communication circuit:

$C_a \text{ (barrier)} > C \text{ (cable)} + C \text{ (gauges)}$ where $C \text{ (gauge)} = 4000 \text{ picofarads per gauge}$

NOTE

If the above equations cannot be met, then the cable length must be reduced or another cable type with lower capacitance specifications must be used. Alternatively, the number of gauges can be reduced.

8. Calculate the maximum network inductance for each circuit (power supply and communications), include only the inductance of the cable. The inductance of each network tap connection must also be included in the total cable inductance. The inductance of each DDA gauge is zero. Verify that the following equations are met to insure the intrinsic safety of the system:

For the power supply circuit:

$L_a \text{ (barrier)} > L \text{ (cable)}$

For the communication circuit:

$L_a \text{ (barrier)} > L \text{ (cable)}$

NOTE

If the above equations cannot be met, then the cable length must be reduced or another cable type with lower inductance specifications must be used.

9. Document all calculations for future reference.

Example Cable Selection

Assumptions:

- 20 DDA gauges on network
- 2000 feet cable length (main trunk)
- 20 network tap connections at 50 feet each (1000 ft. total)
- 24 volt DC power supply

STEP 1. Determine maximum number of gauges connected to the network. Per the assumptions listed above, the desired maximum number of DDA gauges is 20.

STEP 2. Determine the type of safety barriers that will be used for the network. For networks with a high number of gauges (typically more than 5) or long cable lengths, the safety barrier with the lowest end-to-end resistance must be chosen. For this application, the STAHL barriers are selected. For the power supply circuit, STAHL type 8901/31-280/165/80 will be used and for

the communication circuit, STAHL type 8901/32-093/135/70 will be used (per MTS installation drawing # 650511).

- STEP 3. Determine the power supply voltage that will be used for the network. Per the assumptions listed above, a power supply voltage of 24 volts (DC) is chosen. See section 7 of this manual for additional information about power supplies for DDA networks.
- STEP 4. Determine the maximum cable length required for the network trunk. Per the assumptions listed above, the desired maximum cable length for the network trunk is 2000 feet.
- STEP 5. Using the respective cable selection chart, determine the cable gauge (AWG) required for a network with 20 DDA gauges and a maximum cable length of 2000 feet. Based on a power supply voltage of 24 volts (DC) and STAHL type safety barriers, the cable selection graph in figure 6.2 of this manual is used. The cable selection graph in figure 6.2 is repeated below for convenience. Entering the graph from the horizontal axis at 2000 feet and from the vertical axis at 20 gauges gives an intersection point as shown below. Only cables shown to the right of the intersection point can be used. From the graph, cables of 20 AWG or heavier can be used.

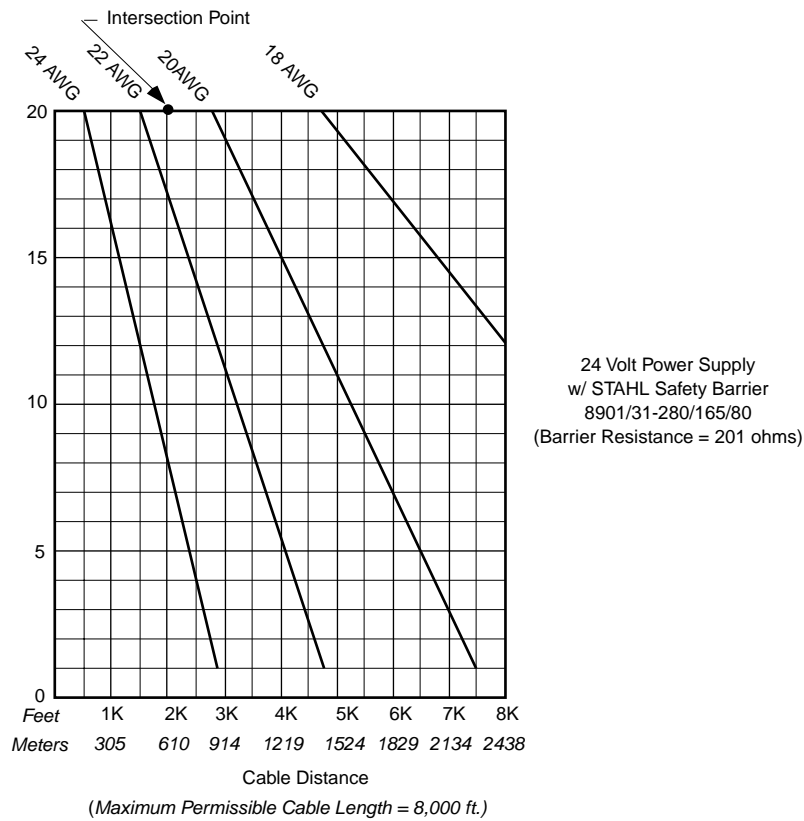

Figure 6.5 Cable Graph (same as 6.2)

NOTE

If a cable selection cannot be found to the right of the intersection point, then the number of gauges or the length of the cable must be reduced to move the intersection point down or to the left, respectively. Alternatively, the power supply voltage can be increased to 26 volts (DC).

STEP 6. Select cables from the recommended cable list that meet the capacitance specifications for the power supply circuit and the communications circuit. For the power supply circuit, the cable capacitance must be 50 picofarads per foot or less. Assuming 20 AWG wire size, the cable lists show six cable selections with a capacitance of 50 picofarads or less. The six suggested types are shown below.

WIRE SIZE (AWG)	CAPACITANCE (Pf/foot)	MANUFACTURER	CABLE #
20	49	BELDEN	8762
20	49	BELDEN	9464
20	40	CAROL	C2519
20	45	CAROL	C2520
20	46	MANHATTAN	M39047
20	42	DEKORON	1T52-0810T

The BELDEN 8762 will be chosen for this example.

For the communications circuit, the cable capacitance must be 24 picofarads per foot or less. Assuming 20 AWG wire size, the cable lists show six cable selections with a capacitance of 24 picofarads or less. The six suggested types are shown below.

WIRE SIZE (AWG)	CAPACITANCE (Pf/foot)	MANUFACTURER	CABLE #
20	22	BELDEN	83393
20	16	BELDEN	9207
20	22	CAROL	C2519
20	16	CAROL	C8010
20	16	MANHATTAN	M4270
20	23	DEKORON	1T52-0810T

The BELDEN 83393 will be chosen for this example.

STEP 7. Calculate the maximum network capacitance for each circuit (power supply and communications).

For the power supply circuit:

$$C_a (\text{barrier}) > C (\text{cable}) + C (\text{gauges})$$

where $C (\text{gauge}) = 1600$ picofarads per gauge

For the communication circuit:

$$C_a (\text{barrier}) > C (\text{cable}) + C (\text{gauges})$$

where $C (\text{gauge}) = 4000$ picofarads per gauge

Per the assumptions listed above:

- A. there is 2000 feet of cable for the main trunk
- B. there is 1000 feet of cable for all network tap connections (total)
- C. 20 DDA gauges
- D. $C_a (\text{barrier}) \text{ STAHL } 8901/31-280/165/80 = 0.3 \text{ uF maximum}$
- E. $C_a (\text{barrier}) \text{ STAHL } 8901/32-093/135/70 = 7.8 \text{ uF maximum}$

For the power supply circuit using BELDEN 8762 cable:

$$C (\text{cable}) = (3000 \text{ feet}) \times (49 \text{ pF/foot}) = 147,000 \text{ pF} = 0.147 \text{ uF}$$

$$C (\text{gauges}) = (20) \times (1600 \text{ pF/gauge}) = 32000 \text{ pF} = 0.032 \text{ uF}$$

$$C (\text{total}) = 0.147 \text{ uF} + 0.032 \text{ uF} = 0.179 \text{ uF}$$

Since the power supply circuit capacitance of 0.179 uF is less than the maximum allowed for the STAHL power supply circuit barrier (0.3 uF), the power supply circuit meets intrinsic safety requirements with respect to capacitance.

For the communication circuit using BELDEN 83393 cable:

$$C (\text{cable}) = (3000 \text{ feet}) \times (22 \text{ pF/foot}) = 66,000 \text{ pF} = 0.066 \text{ uF}$$

$$C (\text{gauges}) = (20) \times (4000 \text{ pF/gauge}) = 80000 \text{ pF} = 0.080 \text{ uF}$$

$$C (\text{total}) = 0.066 \text{ uF} + 0.080 \text{ uF} = 0.146 \text{ uF}$$

Since the communication circuit capacitance of 0.146 uF is less than the maximum allowed for the STAHL communication circuit barrier (7.8 uF), the communication circuit meets intrinsic safety requirements with respect to capacitance.

NOTE

If the above equations cannot be met, then the cable length must be reduced or another cable type with lower capacitance specifications must be used. Alternatively, the number of gauges can be reduced.

STEP 8. Calculate the maximum network inductance for each circuit (power supply and communications).

For the power supply circuit:

$$L_a (\text{barrier}) > L (\text{cable})$$

For the communication circuit:

$$L_a (\text{barrier}) > L (\text{cable})$$

Per the assumptions listed above:

- A. there is 2000 feet of cable for the main trunk
- B. there is 1000 feet of cable for all network tap connections (total)
- C. $L_a (\text{barrier}) \text{ STAHL } 8901/31-280/165/80 = 5.1 \text{ mH maximum}$
- D. $L_a (\text{barrier}) \text{ STAHL } 8901/32-093/135/70 = 4.8 \text{ mH maximum}$
- E. use 0.2 uH/foot for cable inductance parameter per ISA RP12.6

For the power supply circuit using BELDEN 8762 cable:

$$L (\text{cable}) = (3000 \text{ feet}) \times (0.2 \text{ uH/foot}) = 600 \text{ uH} = 0.6 \text{ mH}$$

$$L (\text{gauges}) = 0 \text{ mH}$$

$$L (\text{total}) = 0.6 \text{ mH}$$

Since the power supply circuit inductance of 0.6 mH is less than the maximum allowed for the STAHL power supply circuit barrier (5.1 mH), the power supply circuit meets intrinsic safety requirements with respect to inductance.

For the communication circuit using BELDEN 83393 cable:

$$L (\text{cable}) = (3000 \text{ feet}) \times (0.2 \text{ uH/foot}) = 600 \text{ uH} = 0.6 \text{ mH}$$

$$L (\text{gauges}) = 0 \text{ mH}$$

$$L (\text{total}) = 0.6 \text{ mH}$$

Since the communication circuit inductance of 0.6 mH is less than the maximum allowed for the STAHL communication circuit barrier (4.8 mH), the communication circuit meets intrinsic safety requirements with respect to inductance.

NOTE

If the above equations cannot be met, then the cable length must be reduced or another cable type with lower inductance specifications must be used.

STEP 9. Document all calculations for future reference.

6.4 DDA Cable Installation Guidelines

All cable installations must meet the requirements of an intrinsically safe (I.S.) system installed in hazardous locations. In addition to the capacitance and inductance of the cable (see previous section), the designer and installer of an I.S. system must be aware of field wiring requirements. Each particular application must meet both national codes and any local codes covering wiring practices for I.S. systems. An excellent reference on this subject is ISA's (Instrument Society of America) Recommended Practice RP12.6, titled "Installation of Intrinsically Safe Systems for Hazardous (Classified) Locations". This reference can be used in conjunction with the National Electric Code (NEC) or other applicable reference manuals to insure proper installation of cables and associated I.S. equipment in hazardous areas. Also see appendix A of this manual for additional publications dealing with this subject.

The following section deals with other cabling considerations. These topics should be reviewed prior to planning and installing a DDA network.

1. Cable types - Always use shielded, twisted pair cable. This type of cable provides excellent rejection to electrical interference. Differential communication signals (EIA-485) combined with shielded, twisted pair cable will allow the DDA network to operate successfully in electrically noisy environments.
2. Cable shields - Cable shields for the power supply circuit and the communications circuit are terminated (grounded) at the safety barrier end only to the safety barrier ground bus. Do not ground shields at the gauge end of the cable or at any other point throughout the network. Shields at the gauge end should be insulated with heat shrink tubing or electrical tape so that they can not contact any terminals or the gauge housing or the conduit. See MTS installation drawing #650511 for additional information about shield connections. All cable shields must be connected (continued) throughout the network wiring (including junction box connections or cable splices).
3. Cable routing - Cable routing should be planned to minimize the total length of the network trunk. The total length of the network trunk may limit the number of gauges that can be installed on the network. See section 6.3 of this manual for more information on maximum cable lengths and the number of gauges allowed on a network. Always route cables to avoid sources of electrical interference. Electrical noise sources to avoid would include commutating motors, electric welders, switched inductive loads, switched AC mains and other sources that generate large amounts of electrical interference. Always route network cables in cable trays separate from cables that control the above mentioned types of noise sources. In general, I.S. wiring is always routed separate from non-I.S. wiring.
4. Cable splices - All cable splices for the network wiring should be protected by seals and/or terminal boxes. Any connectors or terminal hardware should be of non-corrosive type and attached to

the wires using crimp or crimp and solder (preferred) techniques. All exposed connections must be insulated from other wires, junction boxes, ground, etc.

5. System expansion - Where possible, consider routing the main network trunk through field junction boxes where plant expansion is likely to occur. This can minimize the rewiring of the network to accommodate future gauge installations.
6. Disconnect switches - Where possible, consider the installation of local disconnect switches for each tap connection from the main network trunk. The switches can be used to remove a gauge that requires service from the network without disturbing the operation of other gauges on the network. This would allow field service to be performed without having to power down the entire network. The disconnect switch(s) must disconnect all four of the bus connections (power and communications). Minimum switch ratings: 50 VDC at 100 milliamps. Installed disconnect switches must meet the requirements of applicable wiring codes such that the intrinsic safety of the system is not degraded.
7. Cable polarity - Both the power supply circuit and the communication circuit have polarities associated with them. Use color coded wiring practices to clearly define this information to both installation and maintenance personnel. The DDA gauge is fault protected in the event of polarity reversal, but the system will not operate if the polarities of the circuits are reversed.
8. Documentation - Document all aspects of the network installation. Include items such as cable routing maps, tap locations and lengths, the number of gauges on a given network, gauge communication addresses, cable capacitance and inductance calculations (see section 6 of this manual), location of cable splices and junction boxes, cable types, cable color codes, etc. This information will greatly reduce the time and effort needed to analyze and correct possible problems during system start-up or problems that arise after the system has been in operation.

After a DDA system is installed and field wired, it is recommended that several resistance measurements be performed on the wiring to check for possible mis-wiring or shorts. Refer to section 9 of this manual for additional information about testing and troubleshooting network wiring.

6.5 DDA Wiring Connections

The wiring connections for the DDA gauge are made in two ways. The D7 style gauge uses a liquid tight seal entry into the gauge housing with a 10 foot wire pigtail for connections to the network. The pigtail wires are color coded as shown in figure 6.6. Connections to the pigtail wires should use crimp or crimp and solder techniques to insure reliable connections. The connections should be made in a junction box to protect the connections from environmental elements.

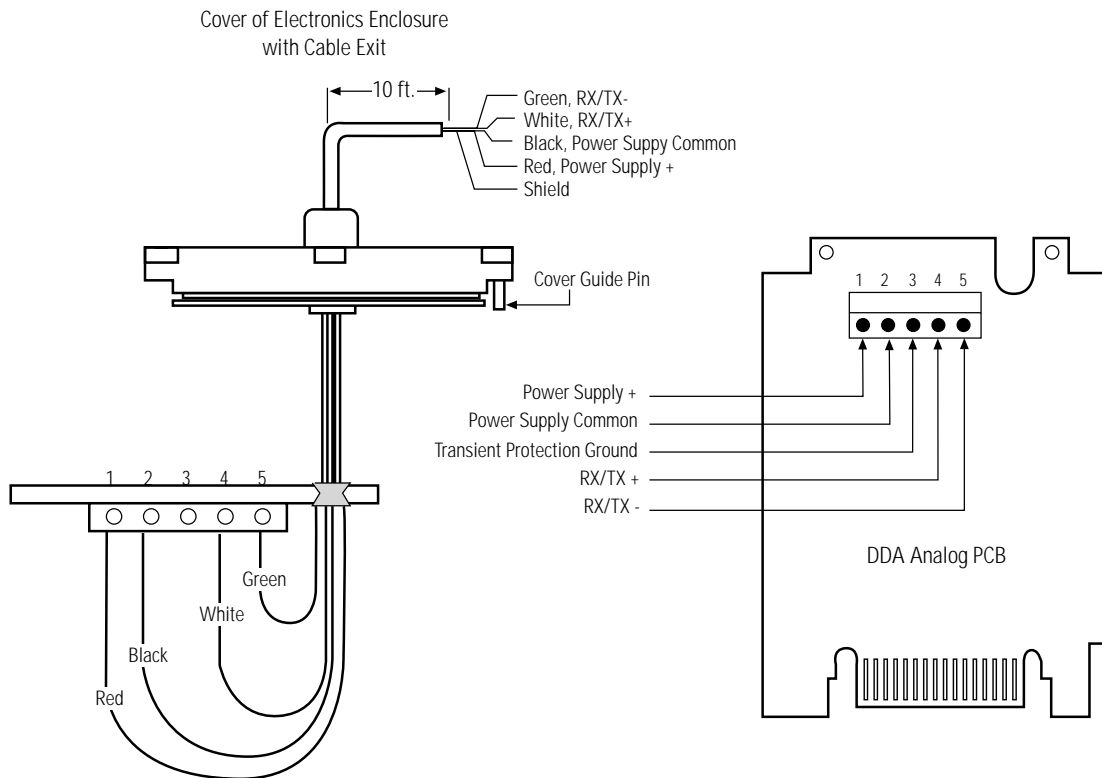

RED - Power supply + (24 or 26 volts DC)
BLACK - Power supply common
WHITE - Communication RX/TX +
GREEN - Communication RX/TX -
SHIELD - Connect to communication cable shield of network

Figure 6.6 D7 Pigtail Wire Connections

For style D8 and D9 gauges, the wire connections are made to the factory supplied 10 foot blue pigtail cable exiting from the 1/2 inch NPT gauge conduit. The customer must provide the necessary conduit connection and junction box to make the field wire terminations to the blue pigtail cable. The customer may shorten the factory supplied pigtail as necessary. See figure 6.7.

CAUTION

Do not remove the blue pigtail cable from the gauge housing as this will void any applicable warranties and allow moisture and water to enter the gauge housing and cause damage to the electronic circuit boards.

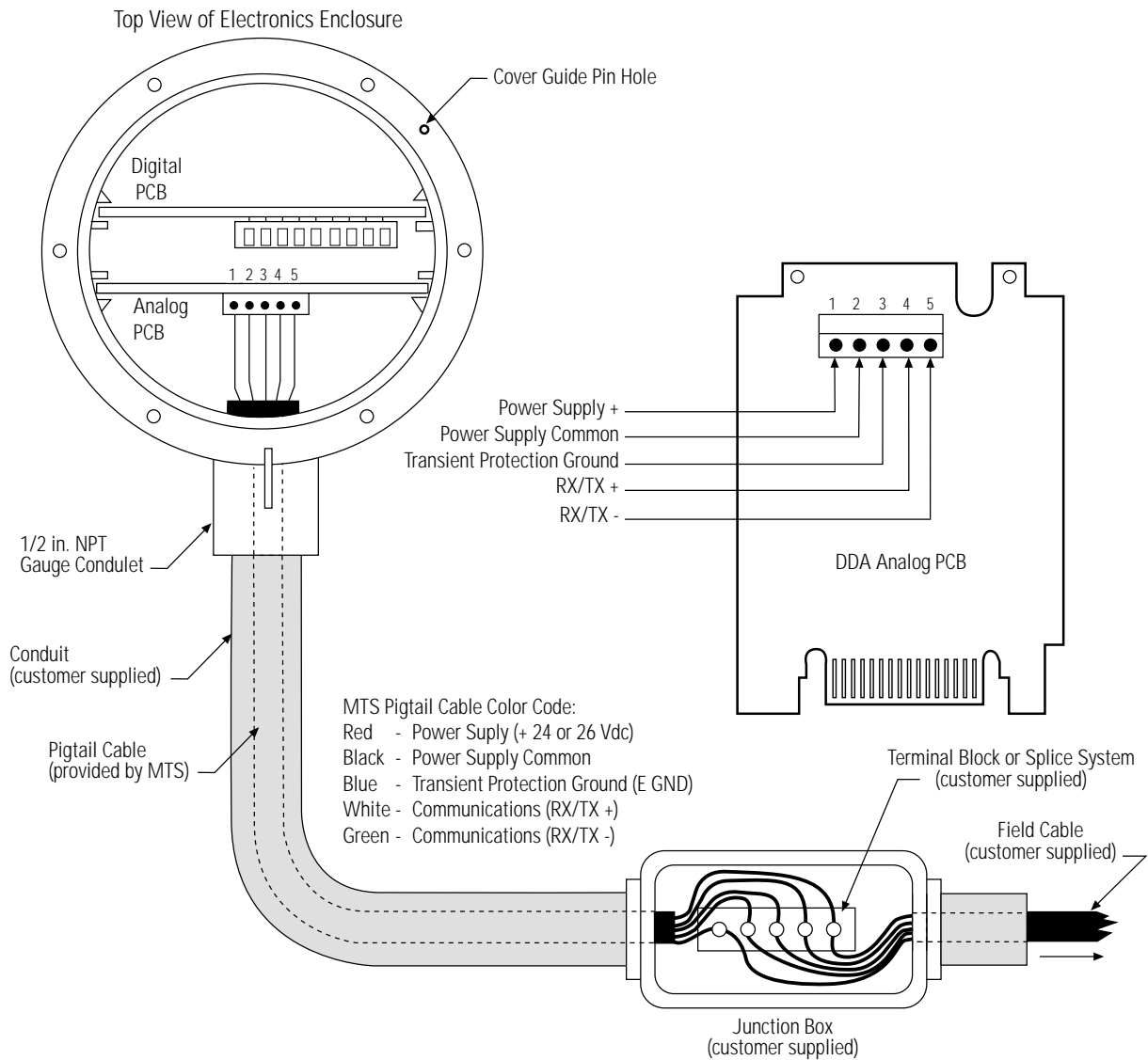
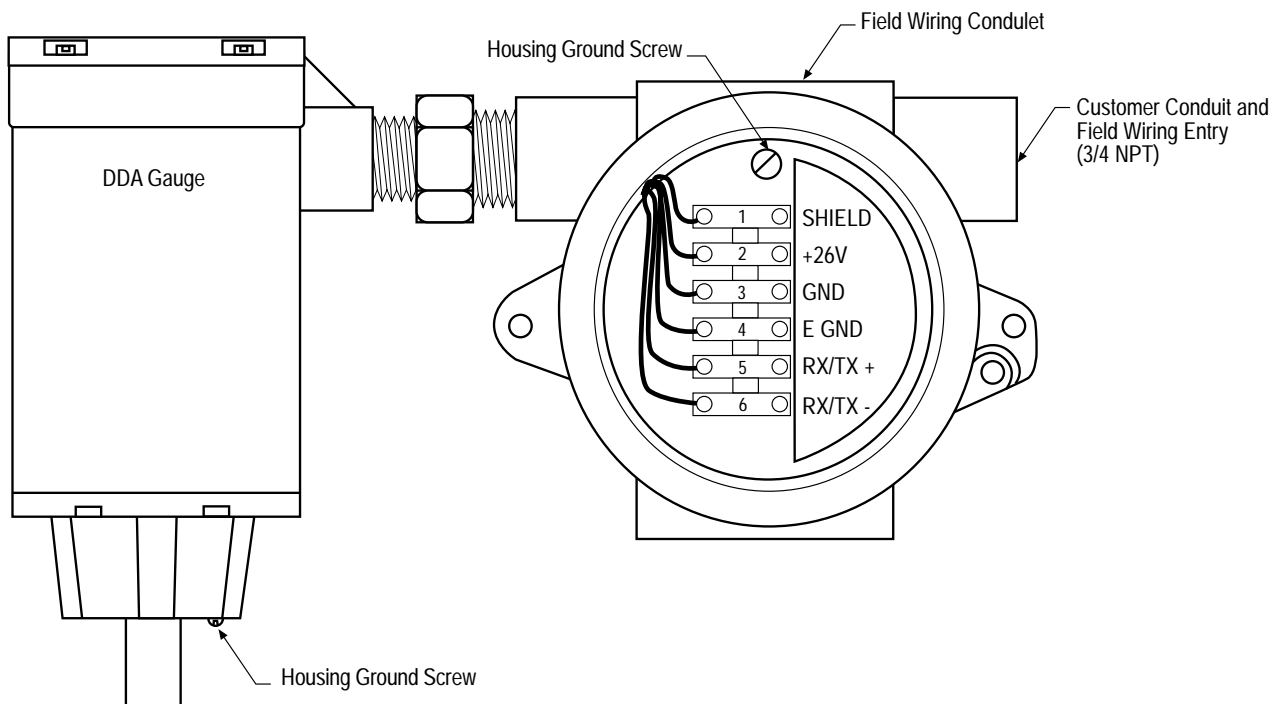

Figure 6.7 D8, D9 Pigtail wire connections

For style LDF gauges, the wire connections are made directly to a six position terminal block located inside the LDF field wiring conduit enclosure. The terminal block connections are shown in figure 6.8.



- Terminal #1 - Shield
- Terminal #2 - Power supply (+24 or 26 volts DC)
- Terminal #3 - Power supply common
- Terminal #4 - Transient protection ground
- Terminal #5 - Communication RX/TX +
- Terminal #6 - Communication RX/TX -

Figure 6.8 Terminal Block Connections for LDF Style Gauges

D8, D9, and LDF style gauges provide an extra terminal for an earth ground connection (E GND). This connection provides an electrical return path for transient protection purposes and should be connected to the local conduit (if grounded) or other grounded bus where the sensor is installed. This connection is important in above ground tank installations where tanks and cable runs may be exposed to large voltage surges or transients. Without this connection, the line-to-ground transient protection circuitry is defeated. Line-to-line transient protection is still active.

Some applications and/or wiring codes may require the gauge housing to be grounded to the tank on which the gauge is installed. An external grounding screw is provided on the gauge housing for this purpose. The screw is colored green and located below the gauge flange as shown in figure 6.9. This connection does not affect the performance of the gauge since the internal electronics are isolated from the gauge housing. LDF style gauges provide an additional housing ground screw inside the field wiring conduit housing. See figure 6.9.

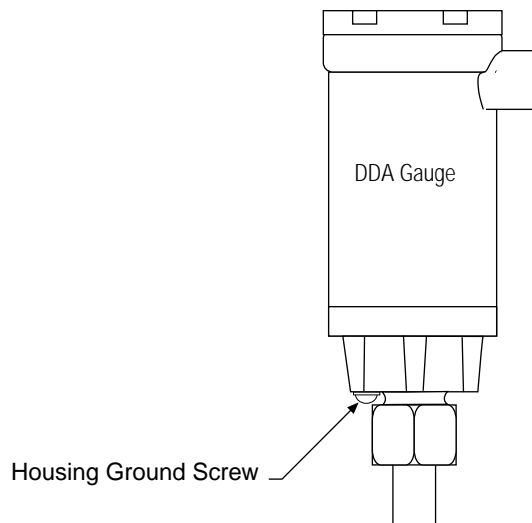

Figure 6.9 Location of Housing Ground Screw

Cable shields for the power supply circuit and the communications circuit are terminated (grounded) at the safety barrier end to the safety barrier ground bus. Cable shields at the gauge end should be terminated to the “shield” position of the condulet terminal block for LDF style gauges and to the shield of the MTS supplied blue pigtail cable for D8 and D9 style gauges. This shield connection is isolated from the gauge housing. Do not ground shields at any other point throughout the network. See MTS installation drawing #650511 for additional information about shield connections. All cable shields must be connected throughout the network wiring.

After a DDA system is installed and field wired, it is recommended that several resistance measurements be performed on the wiring to check for possible mis-wiring or shorts. Refer to section 9 of this manual for additional information about testing and troubleshooting network wiring.

7 DDA POWER SUPPLY REQUIREMENTS

The power supply requirements for the DDA system are non-critical since each DDA gauge incorporates on board voltage regulators. The power supply must be capable of supplying the rated current at the rated voltage as specified below. The use of linear output type supplies is recommended since switching output type power supplies can often radiate RF noise into associated equipment. When installing multiple DDA networks, one power supply may be used to power several networks.

The power supply selected must be able to supply the rated current for all DDA networks connected. Since the rated current draw for each network is 100 milliamps, one power supply connected to three networks must be able to supply 300 milliamps (i.e. 3 x 100). The use of individual power supplies is recommended in case of power supply failure, since networks connected to other individual supplies could still operate.

Power Supply Specifications for 24 Volt or 26 Volt System:

Output Voltage (at rated load): 24 Volts or 26 Volts (DC) \pm 0.5%
Output Current: 100 milliamps (per network)
Load Regulation: 0.5% maximum
Line Regulation: 0.5% maximum
Output Ripple: 100 millivolts, maximum

8 DDA GAUGE SET-UP

The set-up of a DDA gauge on a network involves the setting of the hardware/address decode switch and the optional programming of several software parameters.

8.1 Hardware/Address Programming Switch

The hardware/address decode switch is used to control 4 basic functions of the DDA gauge circuitry as listed below.

1. controls override of the DDA power supply circuitry (for test purposes only)
2. controls enable/disable of the data error detection function
3. controls enable/disable of the communication time-out timer
4. controls the communication address that the respective gauge will respond to when interrogated by the host device.

This switch is located on the digital printed circuit card (PCC) located inside the gauge housing. See figure below for the switch location.

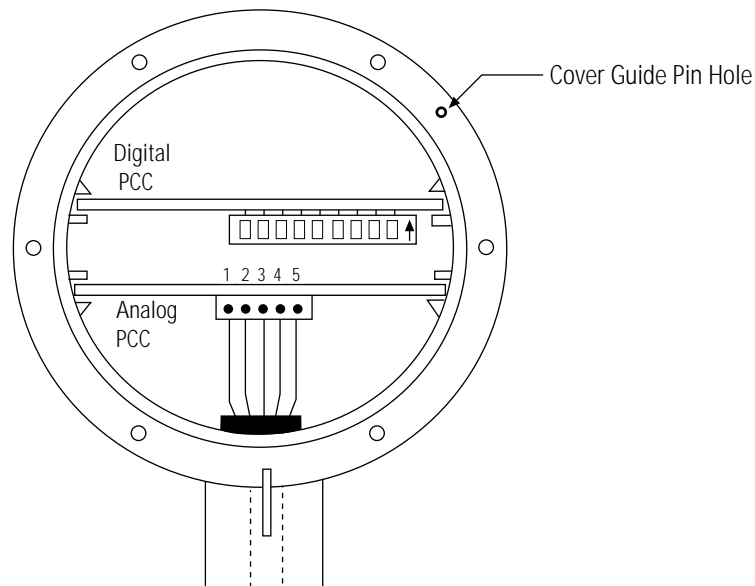

Figure 8.1 Programming Switch located on Digital PCC

The decode switch is a miniature slide switch with nine individual switches. The individual switches are used to control the functions as listed earlier and are defined as shown in figure 8.2.

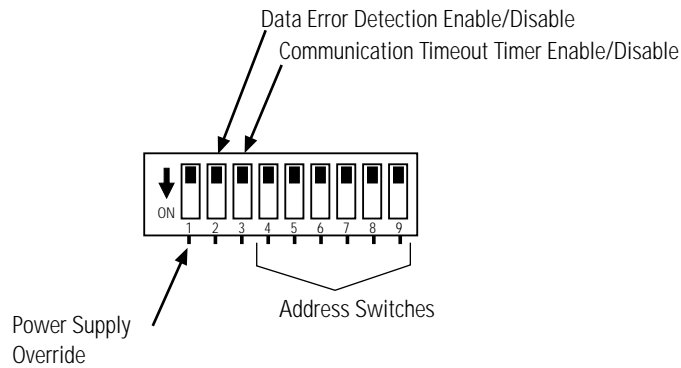

Figure 8.2 Hardware/Address Switch Definitions

The first switch (marked #1) is a power supply override switch. This switch can be turned on to force the DDA gauge out of stand-by (sleep) mode. This switch is only used for test purposes and should always be off when the gauge is in normal operation mode.

Switch position 2 controls the enabling or disabling of the data error detection (DED) function. The DDA gauge supports two DED modes, 16 bit checksum and 16 bit CRC. The error detection functions are used to check the integrity of transmitted data over the network. Once enabled (switch #2 in the ON position), the error detection mode is selected by programming a certain memory location in the DDA on-board memory. The error detection function can also be disabled in this manner. The assigned memory location can be modified through the communication interface using special DDA commands. See sections 8.2 and 10.3 for additional information about the DED function.

Switch position 3 controls the enabling or disabling of the communication time-out timer (CTT) function. The DDA gauge supports a special software timer function that serves as a watchdog monitor on the network activity. Certain DDA commands and communication sequences have specific time-outs associated with them. If the time-outs are exceeded, the DDA gauge will go back to stand-by mode. This function is used to keep several gauges from becoming active at once and trying to communicate at the same time. This function works in tandem with a network activity supervisor function that also puts the gauge back in stand-by mode if other devices start to communicate on the network. Once enabled (switch #3 in the ON position), the CTT can also be controlled by programming an assigned memory location. Only one mode is supported but the timer can be enabled and disabled through the communication interface. See sections 8.2 and 10.3 for additional information about the CTT function.

Switch positions 4 through 9 are used to program the individual gauge network communication address. The address of a DDA gauge is programmed via these switches using a binary code. Valid addresses range from C0 hex (192 decimal) to FD hex (253 decimal).

NOTE

Gauges addresses FE and FF hex are reserved for test functions and cannot be used for network communication addresses.

The base address C0 hex (192 decimal) is programmed by setting individual switches 4 through 9 in the ON position. Each successive address (C1 hex to FD hex) is then coded in binary values with these six address switches. The binary value (weighting) of each switch is shown in figure 8.3

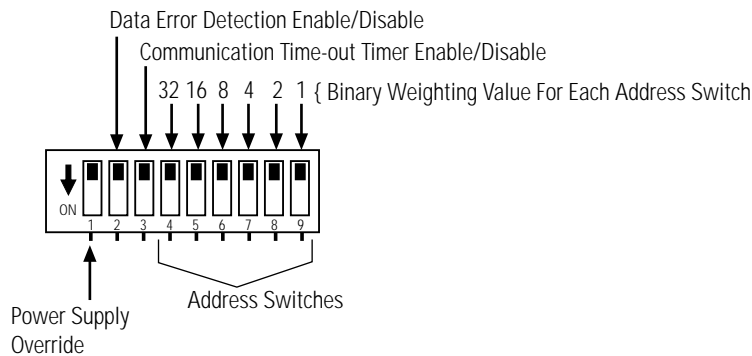
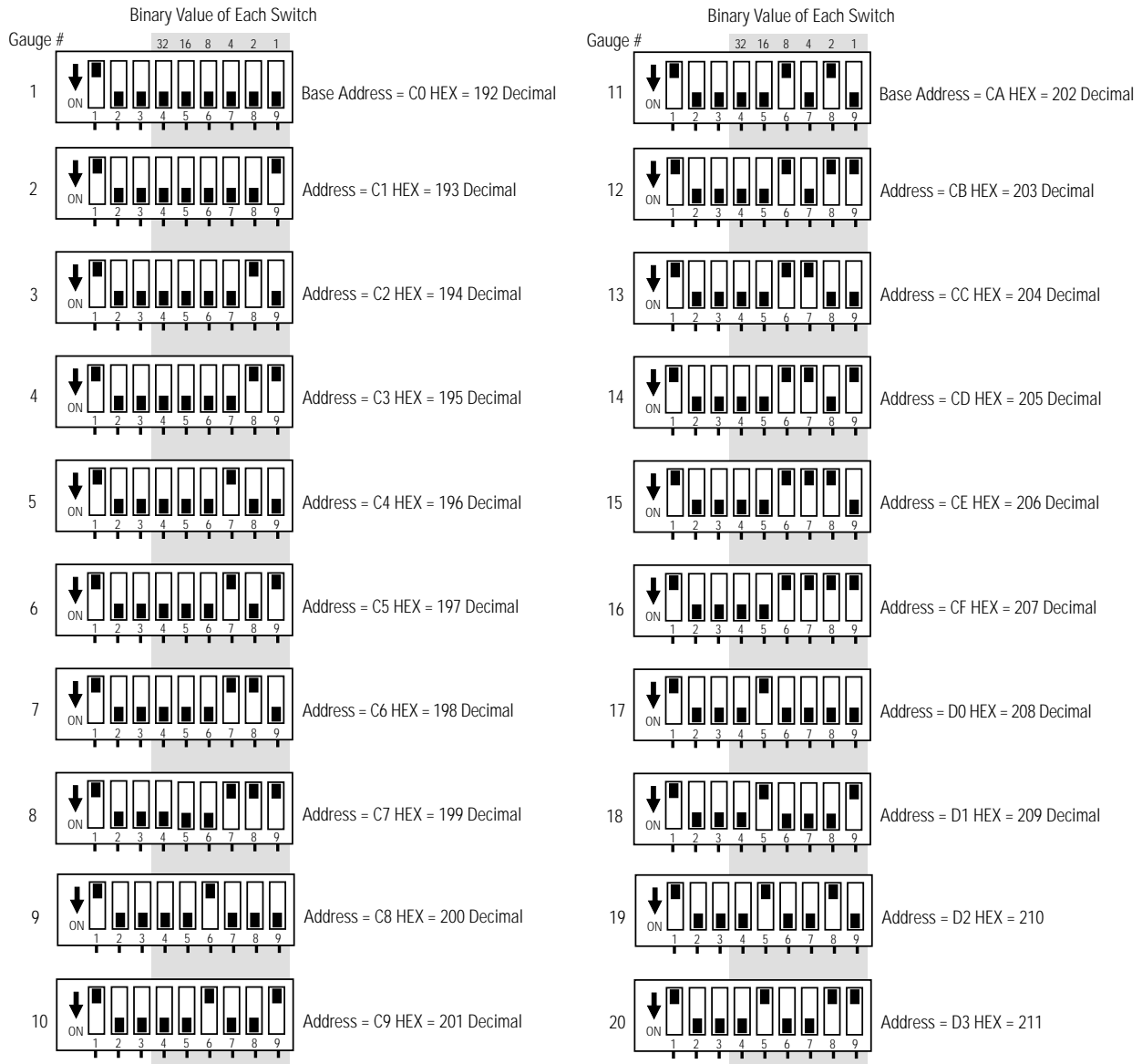

Figure 8.3 Binary Weighting of Address Switches

Starting from right side of the switch, position 9 is assigned a binary value of 1, switch position 8 is assigned a binary value of 2, and so on up to a value of 32 for switch position 4. Examples of gauge address settings are shown in figure 8.4

NOTE
The address switch decoding circuitry interprets the address switch positions opposite to the ON label on the switch housing. For example, switches 4 through 9 in the down position (ON) are read as a binary 0, establishing the base address of C0 hex (192 decimal). Setting switch 9 to the up position adds 1 to the base address creating 193 decimal (192 +1). Setting switch 8 in the up position adds 2 to the base address creating 194 decimal (C3 hex). Setting both switches 8 and 9 in the up position will add 3 (192 + 2 +1) to the base address creating 195 decimal (C4 hex), and so on.

NOTE
Most applications, including MTS Level Plus Tank Monitors and LPS-80 software require the 'Data Error Detection' and the 'Communication Time-Out Timer' to be enabled (switches 2 and 3 in On position, see fig. 8.2).



*Figure 8.4 Example Address Switch Settings
(For all addresses see Appendix D)*

Typically the address for each gauge is defined when the network is first planned and laid out. The switch can then be set with the proper address when the gauge is being installed and field wired to the network. This eliminates having to remove the gauge cover at a later time to program the address switch. Alternatively, the customer can request to have the factory pre-program the necessary gauge addresses for each gauge.

Typically the gauges are defined from address C0 to D3 (max. 20 gauges per network). If a Level Plus Monitor is installed, you can use only the addresses from C0 to C7 (max. 8 gauges per network). In large networks (more than 20 gauges, max. 20 gauges per loop) you can address each loop of the network from C0 to D3 (similar addresses in different loops) or you can use all the addresses available (from C0 to FD, see also Appendix D).

The digital printed circuit card is manufactured with one of two available types (styles) of switches. One type has the switch actuators positioned on the side of the switch housing while the other type has the actuators positioned on top of the switch housing. See figure 8.5.

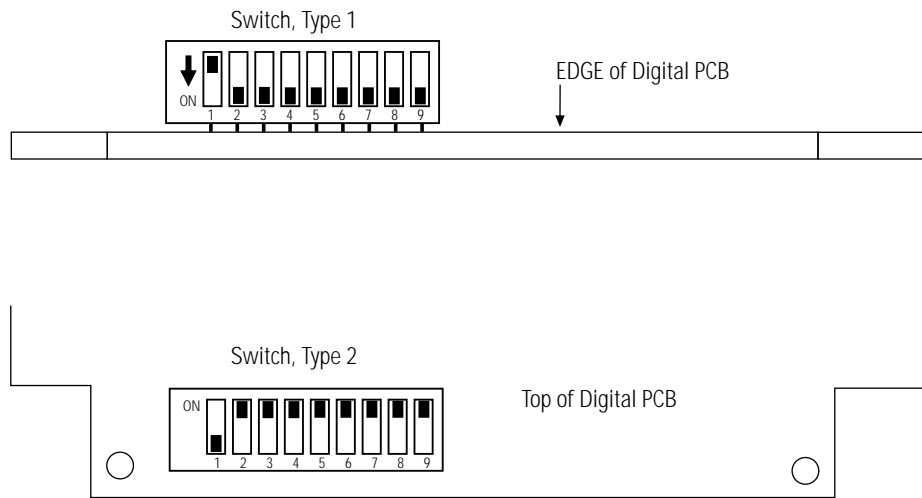

Figure 8.5 Switch Types

The operation of the two types of switches is the same. There is a symbol on the left side of the switch housing indicating the ON position for each type of switch. Observe this symbol to determine when a switch is on or off.

NOTE

All gauges are shipped from the factory with all the switches in On position. You must properly address the gauge(s) according with your network before power up (see fig. 8.4 and Appendix D).

8.2 Programmable Gauge Parameters

The gauge electronics includes an on-board EEPROM (Electrically Erasable Programmable Read Only Memory) where programmable parameters are stored. Many of these parameters are required by the firmware for basic gauge operation. Others are parameters that are related to the tank or the equipment that the gauge is installed on. All of the parameters are pre-programmed during the manufacturing process. Certain parameters can be reprogrammed (adjusted) by the user to calibrate the gauge to a particular tank or application. Reprogramming of the parameters is done through the communication interface using specially assigned commands and data formats. Commands are available to both read and write the programmable parameters. Additional information about the commands and required data formats can be found in section 10.3 of this manual.

NOTE

MTS has developed two communication tool products to aid customers in programming or adjusting DDA memory parameters. DDASETUP is an IBM-PC based program that can be used with the customer's IBM-PC compatible computer. This method requires the purchase of an EIA-232 to EIA-485 signal converter. The second product is the HT-100 hand-held terminal. The HT-100 is an integrated terminal providing direct EIA-485 output signals. Both tools provide easy access to all user accessible DDA memory parameters.

The following is a list of the user programmable parameters along with a description of how the parameters are used by the DDA gauge.

1. Number of floats - The number of floats parameter is used by the firmware to determine the correct number of floats on the gauge sensing element. Since each float on the sensing element returns a signal, the firmware can check for the absence of signals which indicates a missing float or for the presence of additional signals which might indicate noise from external sources. If either of these conditions is identified, the gauge will output an error code identifying the specific condition. This parameter is factory programmed per the customer sales order information which describes the number of floats to be shipped with the gauge. If the actual number of floats installed on the gauge is changed, this parameter must also be changed for correct firmware operation. See DDA command 55 hex, in section 10.3 of this manual.
2. Number of RTD's - The number of RTD's parameter is used by the firmware to determine how many RTD's (resistive thermal device) to read when a temperature request has been made. This parameter allows the firmware to skip the processing of RTD's that are not installed in the gauge. This improves the overall response time associated with temperature commands. The number of RTD's installed on a gauge is a customer option at the time the gauge is ordered. This parameter is factory programmed per the customer sales order information which describes the number of RTD's to be installed in the gauge. The number of RTD's along with the RTD position data can also be found on the gauge label attached to the outside of the housing. If the actual number of RTD's installed in the gauge is changed, this parameter must also be changed for correct firmware operation. See DDA command 55 hex, in section 10.3 of this manual.
3. RTD positions - The RTD position parameter(s) are used by the firmware to determine which RTD's are submerged in the product. Only RTD's that are submerged 1.5 inches or more below the product float are included in the average temperature calculation. RTD position data is used only for average temperature calculations. Individual RTD temperature calculations are independent of the RTD position parameters. The number of RTD's installed on a gauge (and their position) is a customer option at the time the gauge is ordered. The RTD position parameter(s) are factory programmed per the customer sales order information which describes the RTD positions in the gauge. The number of RTD's along with the RTD position data can also be found on the gauge label attached to the outside of the housing. If the physical RTD positions in the gauge are changed, the RTD position parameter(s) must also be changed for correct firmware operation. See DDA command 59 hex, in section 10.3 of this manual.

NOTE

The RTD position data on the customer sales order always represents the RTD positions with respect to the gauge tip. The firmware requires the RTD position data to be programmed with respect to the gauge flange. The gauge label provides the RTD position data with respect to both the tip and the flange. The RTD position data with respect to the flange is always shown on the label enclosed in brackets (i.e. [xxx]). Always use the position information enclosed in brackets when programming the DDA memory. RTD #1 is always listed first on the label.

4. Gradient - The gradient parameter is used by the firmware to calculate the absolute position of a float. This parameter has the units of microseconds per inch and represents the characteristic response time of the level sensing element (waveguide). The gradient parameter is factory programmed using data collected from the factory calibration fixtures and is also listed on the gauge label attached to the outside of the housing. The gradient factor programmed in the gauge must always match the gradient parameter listed on the gauge label. See DDA command 56 hex, in section 10.3 of this manual.
5. Float zero position(s) - The float zero position parameter(s) are used by the firmware to offset the calculated level data. The float zero positions can be reprogrammed (or adjusted) to calibrate the measured float positions to the actual product height in the tank. Independent zero positions are provided for the product float and the interface float. From a user standpoint, the zero position is the position along the gauge stroke that is defined (and displayed) as zero (0.000) level. Typically the zero position is set equal to the gauge length for innage type level measurements. Then when the float is at the end of the gauge, the displayed output will be zero (0.000) inches. As the float is moved upwards toward the flange of the gauge, the displayed level output will be positive and relative to the programmed zero position. If the float goes below the defined zero position, the displayed level output will be negative. The zero reference can be assigned any value between 0.000 and 9999.999 inches. There are two ways to program the zero position parameters. One method (using DDA command 57 hex) allows the user to input the absolute zero position data directly into memory. The second method (using DDA command 58 hex) allows the user to input the current float level (or product height) and the DDA will calculate the required zero position such that the displayed level data now matches the measured product (or interface) height. The second method precisely calibrates the gauge and float system to the product in the tank. The float position parameters are factory programmed equal to the gauge length. The gauge length information is also listed on the gauge label for reference.
6. Firmware control code #1 - Firmware control code #1 is used by the firmware to control the mode of the data error detection (DED) function and the communication time-out timer (CTT) function. Both of these functions are programmable through the communication interface, but are also controlled by the hardware decode switches located on the digital printed circuit card. See section 8.1 of this manual for additional information about the hardware decode switches. The hardware decode switches are used to enable or disable each function and always override the current firmware setting. If the function is enabled via the switches, then the firmware control code is used to determine the current mode of each function. In the case of the DED function, the firmware control code determines what error detection method is used, i.e. 16 bit checksum, 16 bit cyclic redundancy check or none (can also be disabled via the firmware control code). For the CTT function, the firmware control code just enables or disables the time-out timer function. Firmware control code #1 is factory programmed for 16 bit checksum DED and CTT enabled, i.e. data codes "00". See DDA commands 50 and 5A hex, in section 10.3 of this manual. The hardware decode switches are both factory set to on, i.e. data error detection function enabled and communication time-out timer function enabled. If the DED and CTT functions are not used, the decode switches can be set off.

NOTE

See sections 8.1 and 8.2 of this manual for additional information about the data error detection function and communication time-out timer function. Also see section 10.3, commands 50 Hex and 5A Hex for additional functions controlled by the DDA firmware control code.

7. Hardware control code #1 - Hardware control code #1 is used by the firmware to control certain hardware circuitry functions such as amplifier gain, waveguide driver levels, interrogation rates, etc. The control code value is determined by the factory when the gauge is manufactured and is specific to each gauge. The 6 digit control code for each gauge is listed on the gauge label next to the letters "CCxxxxxx", as shown. The hardware control code is programmable through the communication interface, and only needs to be reprogrammed if the digital printed circuit card is replaced for any reason. The control code does not need to be altered if the analog printed circuit card is replaced. See DDA commands 51 and 5B hex, in section 10.3 of this manual.
8. Linearization data (optional) - Linearization data is also stored in the gauge memory for certain style gauges that require precision linearity specifications.
9. Reference magnet position - The reference magnet position data is used by the firmware during level processing to remove any temperature dependence on the output level information. The reference position data is automatically measured and stored in the EEPROM upon execution of DDA command 5E hex. No additional data input is required. The reference magnet position data is factory programmed and only needs to be reprogrammed if the digital printed circuit card has been replaced.

NOTE

If the digital printed circuit card is ever replaced because of component failure or other reasons, all of the parameters must be reprogrammed. In addition a special command (command 5E hex) must be executed to establish the reference magnet position data. The reference magnet position data is used by the firmware during level processing to remove any temperature dependence on the output level information. Refer to section 9.5 of this manual for additional information about printed circuit board troubleshooting and replacements.

9 MAINTENANCE AND TROUBLESHOOTING

After the initial installation and verification of a DDA system, there is no regular maintenance that needs to be performed on MTS Level Plus gauges. However, it is an accepted practice to verify that the intrinsic safety of the system is maintained throughout the life of the system. This can be performed through periodic inspection programs that check the integrity of the intrinsically safe system and any associated equipment. There are many publications available on the subject of installing and maintaining intrinsically safe systems. These publications provide an excellent reference when structuring a plant maintenance and inspection program. See appendix A of this manual for a partial listing of publications on this subject.

The repair and troubleshooting of devices in an intrinsically safe system must be approached with caution. There are strict rules and guidelines that must be adhered to and it is the responsibility of the user or maintenance personnel to insure that the intrinsic safety of the system is maintained. When making test measurements on an intrinsically safe system, always use test equipment that is approved for use in this application. If this is not possible, then the necessary (hot) permits must be obtained to insure the areas involved in testing of the system are free of hazardous (explosive) materials.

Some basic rules to follow when servicing intrinsically safe systems are:

- Only trained and qualified personnel should be allowed to service I.S. (intrinsically safe) systems and equipment.
- Always use approved test equipment when making test measurements on an I.S. system.
- Always follow manufacturer's installation drawings and instructions when installing or servicing an I.S. system.
- Always make sure power has been removed from an I.S. system before making connections or disconnections.
- Always maintain up-to-date documentation for I.S. installations.
- Never make connections between different I.S. systems.
- Never remove or by-pass the safety barriers of an I.S. system.
- Never substitute any components in I.S. approved equipment.
- Never substitute any associated apparatus in an I.S. system.

Field wiring problems are likely to be the most often encountered problems associated with a DDA network. The list of problems associated with field wiring can typically be grouped into two categories: prestart-up problems and poststart-up problems. Many prestart-up problems are often caused by:

- wiring shorts due to improperly terminated wires
- wiring shorts due to nicked or scraped wires
- wiring shorts due to crossed wires
- improperly connected shields and system grounds
- improper cable types
- excessive cable resistance
- damaged gauge electronics
- improper communication address setting

Many post start-up problems are often caused by:

- cables damaged after installation
- water in cables or conduits
- corroded connections or wire splices
- modifications to existing wiring
- marginally excessive cable resistance
- gauge electronics failures
- electronics damage from high voltage transients, lightning, etc.

The following test procedures can be used to help identify and solve problems associated with field wiring and gauge electronics.

NOTE
Always turn OFF the power supply and host computer device before making any connections or disconnections to the network.

9.1 Cable Isolation Test

The cable isolation test is performed with all DDA gauges, power supply, host computer device, and safety barriers disconnected from network.

1. Make sure all power supplies and computer devices connected to the DDA network are turned OFF.
2. Disconnect each DDA gauge from the network at the gauge terminal block and isolate each wire from other wires and any grounded surface. Disconnect both the power supply and communication circuits.
3. Disconnect the cables (power supply and communication) from the outputs of the safety barriers. Also disconnect the cable shield from the safety barrier ground bus for each circuit.
4. Using an ohmmeter, measure the resistance between each pair of wires as listed below. Make the resistance measurements at the end of the cable that was disconnected from the safety barriers. In all cases, the resistance should be infinite or “open circuit”. Any other measured value, other than infinite indicates a short or leakage between that pair of conductors and must be corrected.

wire pair #1: measure resistance between + 24 volt power supply wire and power supply common wire.

Measured resistance = _____ ohms

wire pair #2: measure resistance between + 24 volt power supply wire and the cable shield (for the power supply circuit).

Measured resistance = _____ ohms

wire pair #3: measure the resistance between the power supply common wire and the cable shield (for power supply circuit)

Measured resistance = _____ ohms

wire pair #4: measure the resistance between the RX/TX+ communication wire and the RX/TX- communication wire

Measured resistance = _____ ohms

wire pair #5: measure the resistance between the RX/TX+ communication wire and the cable shield (for the communication circuit)

Measured resistance = _____ ohms

wire pair #6: measure the resistance between the RX/TX- communication wire and the cable shield (for the communication circuit) Measured resistance = _____ ohms

There must also be isolation maintained (infinite resistance) between the power supply circuit and the communications circuit. Measurements should be made to verify this for all possible wire pair combinations between both circuits.

5. Reconnect all cables and cable shields to the respective safety barriers.
6. Reconnect all gauges, power supply and host computer device.
7. Document results for future reference.

9.2 Cable Connectivity Test

The cable connectivity can be tested by two methods. The first method described is usually done as a prestart-up check before the gauges are connected to the network. This method requires shorting the cable connections at the gauge end one at a time and making resistance measurements at the safety barrier terminals. The resistance measurements can then be compared with expected values to determine if each cable run is properly connected.

The second method described is usually done as a poststart-up check after the gauges and power supply are connected. This method requires the use of a voltmeter to measure voltage levels at the gauge terminal block connections. This can only be done using an intrinsically safe voltmeter or through the use of “hot permits” if the area is considered to have hazardous (explosive) materials present. If it is determined that the area is not hazardous, then standard voltmeters can be used.

Test Method 1

NOTE

If test method #1 is selected, it is recommended to perform the cable connectivity test and the cable isolation test at the same time. Since the gauges are disconnected from the network in both cases, it takes only a small amount of extra time to perform the cable isolation tests. This will insure that any suspected problems are not due to improper cable isolation.

1. Make sure all power supplies and computer devices connected to the DDA network are turned OFF.
2. Disconnect each DDA gauge from the network at the gauge terminal block and isolate each wire from other wires and any grounded surface. Disconnect both the power supply and communication circuits. Do not disconnect the cables from the safety barriers.
3. Determine the end-to-end resistance value of each barrier. Using an ohmmeter, measure the resistance from the input terminal of the safety barrier to the output terminal of the safety barrier. This value will be used along with the cable resistance measurements to determine cable connectivity.

Power supply circuit:

Safety barrier resistance (end-to-end) = _____

Communications circuit:

Safety barrier #1 resistance (end-to-end) = _____

Safety barrier #2 resistance (end-to-end) = _____

Typical values for the approved safety barrier types are shown below. Measured values that vary by more than 20% from those listed may indicate a problem with the safety barrier.

End-to-end resistance values for approved power supply circuit barriers (from manufacturer's data sheets):

- STAHL 8901/31-280/165/80 = 201 ohms
- MTL 728 = 340 ohms
- PEPPERL & FUCHS Z428/EX = 327 ohms

End-to-end resistance values for approved communications circuit barriers (from manufacturer's data sheets):

- STAHL 8901/32-093/135/70 = 100 ohms
- MTL 710 = 85 ohms
- PEPPERL & FUCHS Z111/EX = 83 ohms

4. Using jumper wires, short the wire connections at the first gauge in the system. This must be done at or near the gauge terminal block connection. Use one jumper wire to short the power supply (+) wire end to the power supply common wire end. Use another jumper wire to short the RX/TX+ wire end to the RX/TX- wire end. Make sure that the jumper connections do not touch each other or other metallic surfaces.
5. Measure the resistance for both circuits at the safety barrier input terminals. For the power supply circuit, measure between the power supply (+) barrier input terminal and the barrier ground connection (bus bar). For the communication circuit, measure between the RX/TX+ barrier input terminal and the RX/TX- barrier input terminal. List the measured values.

Power supply circuit (with gauge #1 wires shorted):

Measured loop resistance = _____ ohms.

Communication circuit (with gauge #1 wires shorted):

Measured loop resistance = _____ ohms

6. Calculate the theoretical loop resistance for the power supply circuit and the communication circuit. This is done by using the resistance specifications for the given cable (dependent on wire size - AWG), the length of the cable run from the safety barrier to the gauge and the end-to-end resistance measurements from the safety barriers (measured previously). Typical resistance specifications for common wire sizes are shown below. For more accurate calculations, actual wire data sheets can be consulted for resistance parameters.

	Stranded Core (ohms)	Solid Core (ohms)
16 AWG	3.7	4.0
18 AWG	5.9	6.4
20 AWG	10.3	10.2
22 AWG	14.7	16.1
24 AWG	23.3	25.7

(values listed above indicate ohms per 1000 feet per conductor)

Since the cable has a power conductor and a return conductor, the resistance figures for the cable must be doubled.

For the power supply circuit:

Total loop resistance = barrier resistance (1 barrier) + cable resistance

Example:

Assume STAHL 8901/31-280/165/80 safety barrier and 750 feet of 18 AWG stranded cable between gauge #1 and the safety barrier.

Barrier resistance (measured) = 212 ohms

Cable Resistance (doubled) = 11.8 ohms per 1000 feet

Calculated total loop resistance = $212 + 11.8 \times (750/1000) = 220.85$ ohms

For the communication circuit:

Total loop resistance = barrier resistance (2 barriers) + cable resistance

Example:

Assume MTL 710 safety barriers and 2500 feet of 18 AWG stranded cable between gauge #1 and the safety barriers.

Barrier #1 resistance (measured) = 72 ohms

Barrier #2 resistance (measured) = 75 ohms

Cable Resistance (doubled) = 11.8 ohms per 1000 feet

Calculated total loop resistance = $72 + 75 + 11.8 \times (2500/1000) = 176.5$ ohms

7. Compare measured loop resistance values with calculated loop resistance values. The measured total loop resistance should match the calculated (theoretical) total loop resistance within +/- 10 percent. Any larger variations may indicate a connectivity problem for the respective gauge on the network and must be corrected.
8. Repeat steps 3, 4, 5, and 6 above to verify proper connectivity for each gauge on the network. The cable length for each gauge will vary based on the location of each gauge on the network.
9. Document results for future reference.

Test Method 2

This test method for cable connectivity is performed with the +24 volt power supply connected. The host computer device must be disconnected from the communication circuit. All voltage and current measurements must be done with approved intrinsically safe instruments or by using standard equipment and having secured the necessary "safe area" work permits.

1. Make sure all power supplies and computer devices connected to the DDA network are turned OFF. The host computer device must be disconnected from the network.
2. Temporarily disconnect the positive wire between the network power supply and the input terminal of the power supply circuit safety barrier.
3. Connect a current (milliamp) meter in series between the power supply and the safety barrier input terminal.
4. Turn on the network power supply and measure the current being drawn by the DDA network. List below for future use.

Power supply current (all gauges in stand-by mode) = _____ milliamps

This is the current drawn from the power supply for all gauges operating in stand-by (sleep) mode. The measured current must meet the specified maximum and minimum values for a network of N

gauges. The specified current draw for each gauge in a stand-by mode is 1.0 milliamps (minimum), 1.2 milliamps (typical) and 1.5 milliamps (maximum). For a network of N gauges, the specified maximum current draw will be $N \times 1.5$ milliamps. The typical current draw will be $N \times 1.2$ milliamps. The minimum current draw will be $N \times 1.0$ milliamps. If the measured value exceeds the maximum specified value, or is less than the minimum specified value, a problem exists in the network wiring or with the electronics of one or more gauges. This problem must be identified and fixed before continuing with the cable connectivity test. Refer to “Gauge Current and Voltage Tests” in section 9.3 for procedures in identifying current consumption problems.

5. Turn OFF the network power supply. Remove the current meter from the circuit and reconnect the power supply directly to the power supply safety barrier.
6. Turn ON the network power supply. With an intrinsically safe measuring instrument (voltmeter or other), measure the voltage at each gauge terminal block for both the power supply circuit and the communication circuit. If an I.S. measuring instrument is not available, approved procedures and “safe area” work permits have to be used. For the power supply circuit, connect the voltmeter positive lead to the DDA gauge power supply positive terminal (terminal #1 on the terminal block) and the voltmeter negative lead to the DDA gauge power supply common terminal (terminal #2). For the communication circuit, connect the voltmeter positive lead to the DDA gauge RX/TX+ terminal (terminal #4) and the voltmeter negative lead to the DDA RX/TX- terminal (terminal #5). In addition, measure the voltage between each communication line and DC ground (power supply common, terminal #2). See figure 9.1 below.

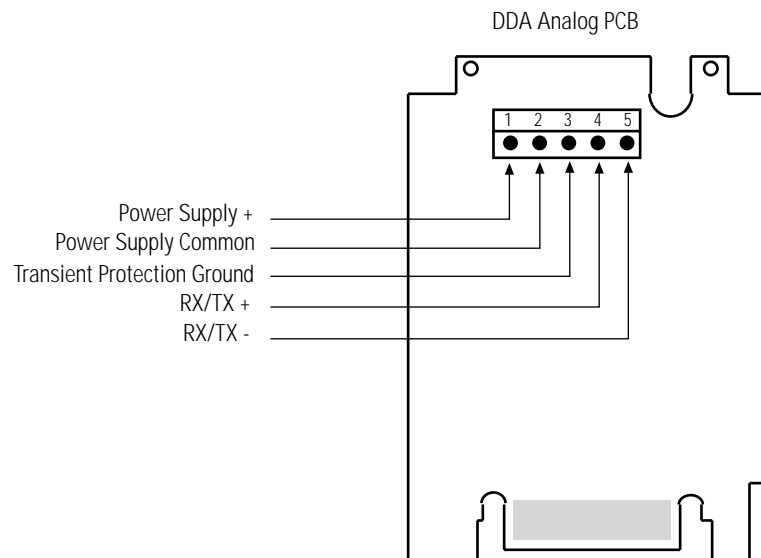

Figure 9.1 Terminal Block Connections

Measure and list the voltage values for each DDA gauge on the network. See example chart in figure 9.2. Next connect a jumper between the RX/TX+ output terminal (i.e. hazardous side) of the safety barrier and the RX/TX- output terminal (i.e. hazardous side) of the safety barrier, shorting the two communication lines together. Again, measure the voltage at each gauge terminal block for the communication circuit only. Add these values to a chart like shown in figure 9.2.

Voltage Measurements at Each Gauge in Network

Gauge #	Voltage - Power Supply On (Terminals 1 - 2)	Voltage - RX/TX Lines Open (Terminals 4 - 5)	Voltage - RX/TX lines open (Terminals 2 - 4)	Voltage - RX/TX lines open (Terminals 2 - 5)	Voltage - RX/TX Lines Shorted (Terminals 4 - 5)
1					
2					
3					
4					
5					
6					
7					
8					
9					
10					
11					
12					
13					
14					
15					
16					
17					
18					
19					
20					

Figure 9.2 Example Chart

7. Compare the measured data with expected values. With all DDA gauges in stand-by mode and a network current draw of less than $N \times 1.5$ milliamps (where N is the number of gauges), the measured voltage at each gauge should be no less than 16.0 volts for the power supply circuit. For the communication circuit, the measured DC voltage at each gauge between terminals 4 and 5 (RX/TX lines open) should be 0.625 (± 0.05) volts. The measured DC voltage between terminals 2 and 4 (RX/TX lines open) should be 2.3 (± 0.25) volts. The measured DC voltage between terminals 2 and 5 (RX/TX lines open) should be 1.7 (± 0.25) volts. The measured DC voltage between terminals 4 and 5 (RX/TX lines shorted) should be 0.45 volts or less. Measured voltage values outside of the above mentioned ranges may indicate cable connectivity problems with one or more gauges and must be corrected for proper network operation. Some possible causes of cable connectivity problems are mentioned below. Each of these items should be investigated as possible causes for network connectivity problems.

- unconnected wires or crossed wires
- wire “opens” or “shorts”
- improperly connected shields and system grounds
- excessive cable resistance
- corroded connections or wire splices

If cable connectivity problems have been ruled out, the improper voltage values may be due to gauge electronic problems. If gauge electronic problems are suspected, proceed to section 9.3 of this manual. This section describes test procedures that can be used to help determine which gauges may be causing network problems.

9.3 Gauge Current and Voltage Tests

The gauge current test can be used to determine if a given gauge is drawing the proper current in both stand-by mode and run mode. A gauge that draws too much current can reduce the available voltage and current to other gauges on the network. This is primarily due to the safety barrier resistance limiting the available voltage and current to the network. The current consumption test can be performed while the gauge is installed and connected to the network or stand alone on the test bench.

Gauge Current Test (gauge installed in tank)

Testing the gauge current in the field requires making current measurements at the gauge terminal block. All voltage and current measurements must be done with approved intrinsically safe instruments or by using standard equipment and having secured the necessary "safe area" work permits.

1. Make sure all power supplies and computer devices connected to the DDA network are turned OFF.
2. Disconnect the positive power supply lead for gauge #1 at the gauge terminal block.
3. Connect an ammeter in series between the gauge power supply terminal (terminal #1) and the positive power supply lead from the network.
4. Turn ON the network power supply and computer device at the control room. The computer device must be in idle mode and not communicating with the gauge(s), or disconnected from the network.

NOTE

A second person can aid in this test by turning the power supply and computer equipment on and off at the correct times. Then communicating via mobile radio to the field personnel to make the measurements when the power supply is on and to only make connections to the network while the power supply is off.

5. Measure the current (in milliamps) of the gauge in stand-by mode. List the measured current value.

Gauge current draw (stand-by mode) = _____ milliamps

6. The next step involves measuring the gauge current in the active (test) mode. The hardware switch on the digital printed circuit card is used to put the gauge into test mode. It is important to note the existing switch settings so that they can be restored after the test is completed.

Existing Switch Settings (ON/OFF)

1 2 3 4 5 6 7 8 9

- Use the hardware switch to force the gauge into test mode #1. This is done by first setting switches 1 through 9 to the OFF position, then by setting switch 1 to ON. Only set switch 1 to the ON position after the other switches have been set or the test mode will not be activated properly. See figure 9.3 for example switch settings to activate test mode #1.

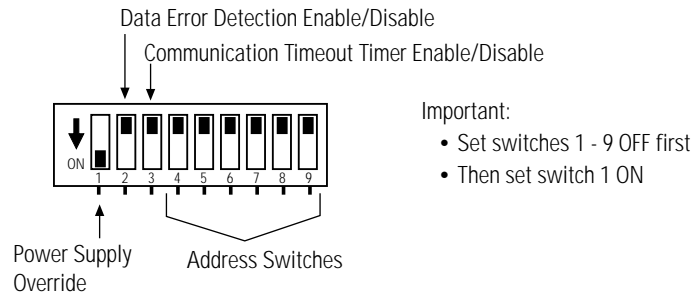

Figure 9.3 Example Switch Setting for Test Mode #1

- Measure the current (in milliamps) of the gauge in test mode #1. List the measured current value.

Gauge current draw (test mode #1) = _____ milliamps

- Set the gauge power supply override switch to OFF and reset switches 2 through 9 back to the original values (as listed in step 6).
- Turn OFF the network power supply and computer equipment at the control room.
- Remove the ammeter from the circuit and reconnect the network power supply lead to the gauge terminal block.
- Repeat the above procedure and measure the stand-by and test mode currents of each gauge on the network (or until the malfunctioning gauge is found).

The specified current draw for a single DDA gauge is listed below.

	minimum	typical	maximum
Gauge current in stand-by mode:	1.0	1.2	1.5 milliamps
Gauge current in test mode #1:	20.0	25.0	30.0 milliamps

NOTE

The "test mode" gauge current listed above is for gauges operating under switch override control. The current may be higher (40.0 milliamps maximum) during gauge start-up or while communicating with the host computer.

A gauge having a "stand-by" current greater than 1.5 milliamps or less than 1.0 milliamps indicates a problem with the on board power supply controller/regulator circuit. This problem is usually associated with the analog printed circuit card, but the digital card can also cause similar symptoms. Also, verify that there are no crossed wires in the field wiring. See section 9.5 for board replacement procedures.

A gauge having a "test mode #1" current greater than 30.0 milliamps or less than 20.0 milliamps

indicates a general problem with the electronics. The problem can be related to either the analog or digital cards. Field wiring should also be verified for possible crossed wires. See section 9.5 for board replacement procedures.

NOTE

Never attempt to repair a printed circuit card. Substitutions of electronic components may impair the intrinsic safety. Return damaged or malfunctioning cards to the factory for repair.

Gauge Current Test (gauge not installed in tank)

Testing the gauge current on the test bench requires removing the gauge from the tank. However, if a second gauge housing is available, only the electronic circuit cards require removal. Insert the electronics cards from the field into the extra gauge housing for the current measurement test. This test will require a 24 volt DC power supply, a milliampmeter, a voltmeter, and a 200 ohm, 1/2 watt resistor.

1. Connect the 24 volt power supply, resistor, ammeter, voltmeter, and gauge as shown in figure 9.4.

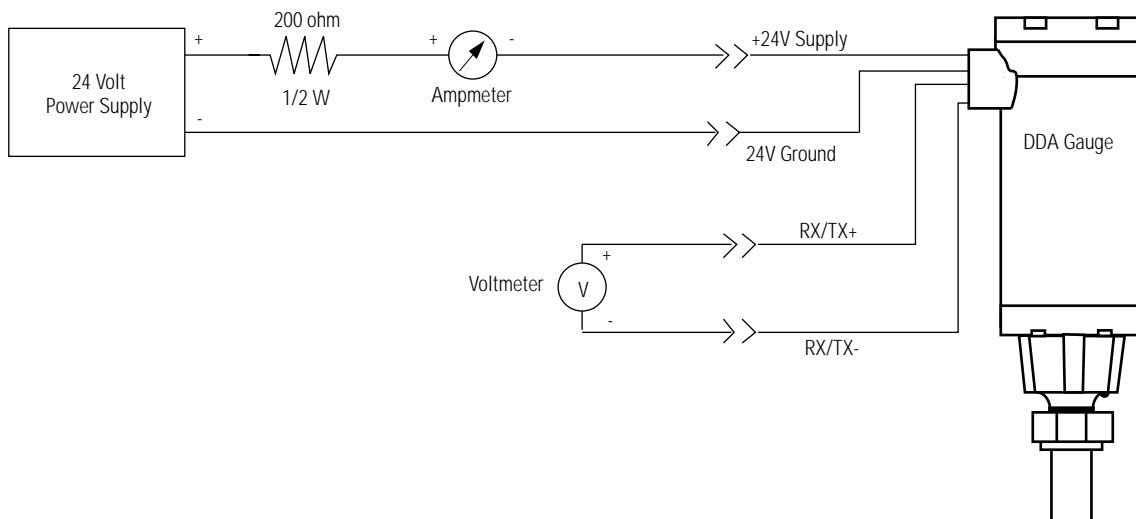

Figure 9.4 Test Configuration

2. Turn ON the 24 volt power supply.
3. Measure the current (in milliamps) of the gauge in stand-by mode. List the measured current value.

Gauge current draw (stand-by mode) = _____ milliamps

4. Measure the voltage across the RX/TX+ and RX/TX- terminals of the gauge.

Voltage across RX/TX terminals = _____ volts

5. The next step involves measuring the gauge current in the active (test) mode. The hardware switch on the digital printed circuit card is used to put the gauge into test mode. It is important to note the existing switch settings so that they can be restored after the test is completed.

Existing Switch Settings (ON/OFF)

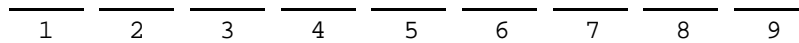

6. Use the hardware switch to force the gauge into test mode #1. This is done by first setting switches 1 through 9 to the OFF position, then by setting switch 1 to ON. Only set switch 1 to the ON position after the other switches have been set or the test mode will not be activated properly. See figure 9.3 for example switch settings to activate test mode #1.
7. Measure the current (in milliamps) of the gauge in test mode #1. List the measured current value.
Gauge current draw (test mode #1) = _____ milliamps
8. Again measure the voltage across the RX/TX terminals while the gauge is in test mode.
Voltage across RX/TX terminals = _____ volts
9. Set the gauge power supply override switch to OFF and reset switches 2 through 9 back to the original values (as listed in step 5).
10. Turn OFF the 24 volt power supply.
11. The voltage measured across the RX/TX terminals should be 0.625 (± 0.05) volts for both tests (stand-by and test mode). Voltage values outside this range indicate electronic problems with the ANALOG printed circuit card. See section 9.5 for board replacement procedures.
12. Compare the current measurements of the gauge with those listed in step 12 of gauge current test in previous section. If the gauge current measurements are out of specification, then a problem exists with either the analog or digital (or both) printed circuit cards. See section 9.5 for board replacement procedures. If the gauge current measurements are in specification, and a network problem still exists, then the network wiring or other network components (gauges, safety barriers, etc.) may be the cause. Verify network wiring using test procedures described in sections 9.1 and 9.2.

Gauge Voltage Test (gauge installed in tank)

The gauge voltage test can be used to determine if a given gauge on a network has adequate voltage for proper operation. The gauge voltage test can only be performed when the gauge is connected to a completely wired network. This is important since the number of gauges on the network and the network cable lengths will determine the maximum available voltage at any gauge connection.

Testing the gauge voltage in the field requires making voltage measurements at the gauge terminal block. All voltage and current measurements must be done with approved intrinsically safe instruments or by using standard equipment and having secured the necessary "safe area" work permits.

1. Turn ON the network power supply and computer device at the control room. The computer device must be in idle mode and not communicating with the gauge(s).
2. Measure the voltage (in volts) at the power supply input terminals on the gauge while in stand-by mode. For the power supply circuit, connect the voltmeter positive lead to the DDA gauge power supply positive terminal (terminal #1 on the terminal block) and the voltmeter negative lead to the DDA gauge power supply common terminal (terminal #2). List the measured voltage value.

Gauge voltage at power supply input terminals (stand-by mode) = _____ volts

3. The next step involves measuring the gauge current in the active (test) mode. The hardware switch on the digital printed circuit card is used to put the gauge into test mode. It is important to note the existing switch settings so that they can be restored after the test is completed.

Existing Switch Settings (ON/OFF)

1 2 3 4 5 6 7 8 9

4. Use the hardware switch to force the gauge into test mode #1. This is done by first setting switches 1 through 9 to the OFF position, then by setting switch 1 to ON. Only set switch 1 to the ON position after the other switches have been set or the test mode will not be activated properly. See figure 9.3 for example switch settings to activate test mode #1.
5. Measure the voltage (in volts) at the power supply input terminals on the gauge while in test mode. List the measured voltage value.

Gauge voltage at power supply input terminals (test mode #1) = _____ volts.

6. Set the gauge power supply override switch to OFF and reset switches 2 through 9 back to the original values (as listed in step 3).
7. Turn OFF the network power supply and computer equipment at the control room.
8. Compare the measured data with expected values. With all DDA gauges in stand-by mode and a network current draw of less than $N \times 1.5$ milliamps (where N is the number of gauges), the measured voltage at each gauge should be no less than 16.0 volts for the power supply circuit. For one gauge in test mode and the other gauges on the network in stand-by mode, the measured voltage for the gauge in test mode must be no less than 8.0 volts for the power supply circuit. Measured values outside of the above mentioned ranges may indicate cable problems or gauge electronic problems with one or more gauges and must be corrected for proper network operation. Some possible causes of network voltage problems are mentioned below. Each of these items should be investigated as possible causes for network voltage problems.
 - unconnected wires or crossed wires
 - wire "opens" or "shorts"
 - improperly connected shields and system grounds
 - excessive cable resistance
 - corroded connections or wire splices
 - gauge in run (or test) mode drawing excessive current
 - other gauges on network drawing excessive stand-by currents or run mode currents
 - improper power supply for network
 - improper safety barrier selection
9. Repeat steps 2 - 8 for each gauge on the network.

Additional Gauge Tests

NOTE

The following tests require the gauge to be connected to a power source and an EIA-485 compatible communication terminal be available. The MTS HT-100 hand-held terminal or DDASETUP software running on an IBM-PC compatible computer can be used for this purpose. Contact the MTS customer service department for additional information on these MTS products.

1. Communication output test - This test can be used to verify the DDA gauge communication output circuitry. This test assumes that the gauge power regulation and microprocessor circuitry are functional. Connect the gauge as shown in figure 9.5 below.

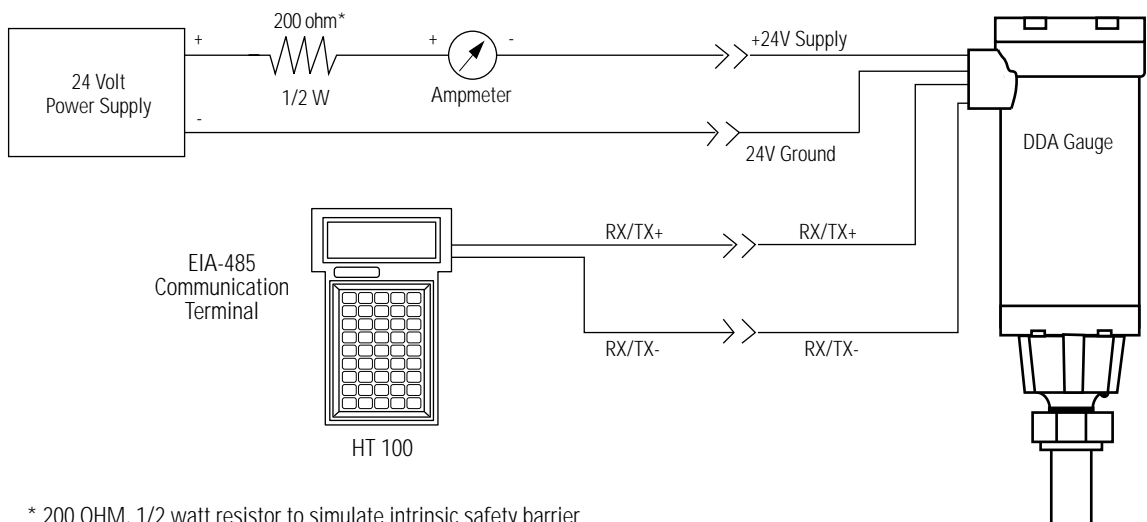

Figure 9.5 Gauge Connection for Communication Output Test

Using the switch located on the digital printed circuit board, activate DDA test mode #1. Refer to section 9.3 in this manual for additional information about activating DDA test mode #1. After test mode #1 has been activated, then set switch #9 to the “on” position. See figure 9.6 below.

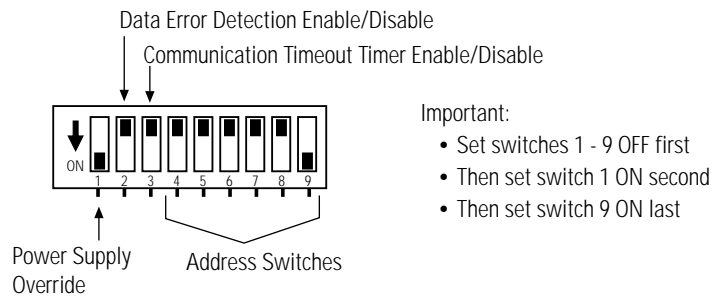

Figure 9.6 Example Switch Setting for Communication Output Test

The DDA gauge will output the following communication test message:

<SOH><STX>ETX><EOT><ENQ><ACK><NAK><ABCDEFGHIJKLMNPOQRTSSTUVUWXYZ.0123456789:->

This test does not perform internal loop back error checking or transmit the data checksum. Refer to section 10.3, command 47 Hex for the communication hardware test that performs loop back error checking. The MTS HT-100 terminal or DDASETUP can be used to issue any DDA command in section 10.3.

2. Level output test - This test can be used to verify the basic level reading function of the DDA gauge. Connect the gauge as shown in figure 9.5. Activate DDA test mode #1 (See Communication output test above) and then set switch #8 to the “on” position. See figure 9.7 below.

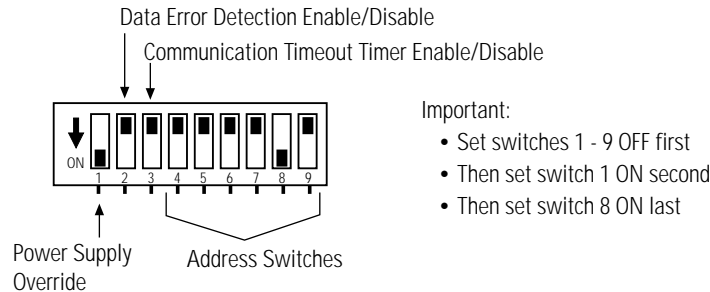

Figure 9.7 Example Switch Setting for Level Output Test

The DDA gauge will then perform a basic level measurement and output the data via the EIA-485 communication lines. The format of the data is the same as for level command 12 Hex (see section 10.3).

3. Temperature output test - This test can be used to verify the basic temperature reading function of the DDA gauge. Connect the gauge as shown in figure 9.5. Activate DDA test mode #1 (see Communication Output Test above) and then set switch #7 to the “on” position. See figure 9.8 below.

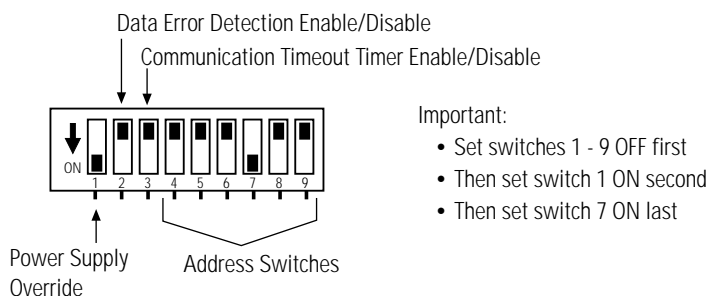

Figure 9.8 Example Switch Setting for Temperature Output Test

The DDA gauge will then perform a basic temperature measurement and output the data via the EIA-485 communication lines. The format of the data is the same as for temperature command 10 Hex (See section 10.3).

9.4 Built in Gauge Diagnostics

The DDA gauge electronics support several built in functional tests. Additional circuitry allows the on-board microprocessor to test certain DDA electronic modules and functions. The built in functional tests are accessed through the communication interface and a special set of commands. See section 10 of this manual for additional information about the command protocol. The following test functions are currently supported by the DDA firmware.

- RAM read/write test
- ROM data checksum test
- EEPROM data checksum test
- Counter integrity test
- Analog converter test
- Communication hardware test
- Driver/Amplifier/Comparator test

9.5 Replacing Printed Circuit Cards

Use the following procedure when replacing printed circuit cards.

1. Make sure all power supplies and computer devices connected to the DDA network are turned OFF.
2. Loosen the six top screws from the cover of the gauge. The cover screws are captive type and will remain in the cover assembly.
3. Remove the cover. If the cover is snug, use a thin bladed screwdriver to separate the cover from the housing. Be careful not to damage the O-ring seal.
4. Replace the defective printed circuit card(s). When replacing the analog printed circuit card, disconnect and reconnect the interface wires as required. Note that the printed circuit cards are keyed to their respective slots in the housing. This keying feature insures that each board can only be installed in the proper slot and in the proper orientation. Do not try to force the printed circuit card into the motherboard connector or damage to the card or connector may result.

The analog card is always installed in the slot nearest the conduit entry. The analog card can be identified by the 5 position terminal block at the top of the card and the 25 position edge card connector at the bottom of the card. The wiring terminal block is always located towards the conduit entry. See figure 9.9.

The digital card is always installed in the slot furthest from the conduit entry. The digital card can be identified by the 9 position hardware/address decode switch at the top of the card and the 15 position edge card connector at the bottom of the card. The hardware/address decode switch is always located towards the analog card. See figure 9.9.

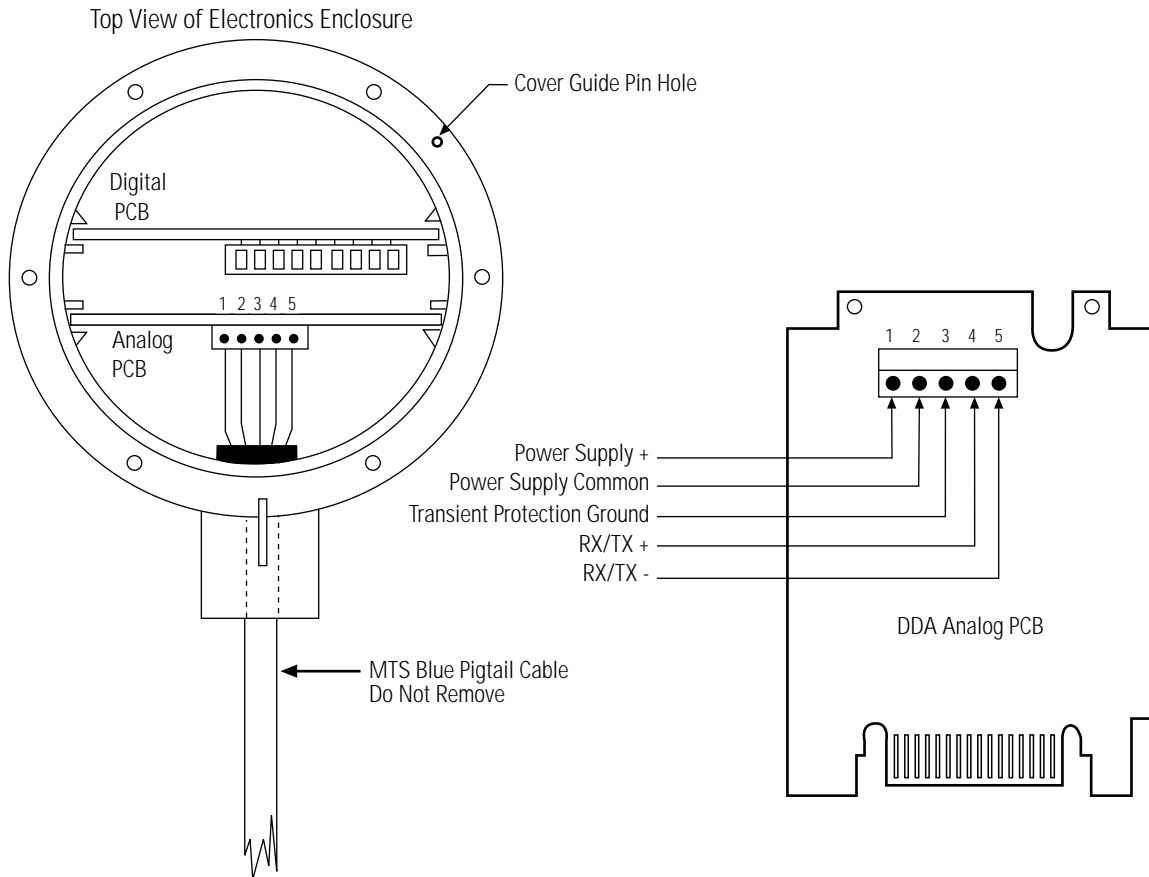

Figure 9.9 Digital and Analog Card Identification

5. When reconnecting the interface wires, the connections are as shown in figure 9.9. Always inspect each connection to insure the wire is properly connected and that there are no loose wire strands shorting between the individual terminals.
6. If the digital printed circuit card has been replaced, re-program the hardware/address decode switch with the proper settings. See section 8.1 of this manual for additional information on setting the hardware/address decode switch.
7. Install the housing cover and tighten the six cover screws. When re-installing the cover it may be necessary to re-moisten the sealing O-ring with silicone grease. This will keep the O-ring from drying out and sticking to the gauge housing, making the cover hard to remove. Note that the cover has a guide pin that determines the correct cover orientation.
8. If the digital printed circuit card has been replaced, it will be necessary to reprogram the on-board EEPROM memory chip. See section 9.6 for additional information on reprogramming the digital card.

9.6 Reprogramming Digital Cards After Replacement

The digital circuit card includes an on-board EEPROM (Electrically Erasable Programmable Read Only Memory) where programmable parameters are stored. Many of these parameters are required by the firmware for the basic gauge operation. Others are parameters that are related to the tank or the equipment that the gauge is installed on. If a digital card has been replaced, each of the gauge parameters in the new card must be reprogrammed to be the same as the original card. The gauge parameters can be reprogrammed through the communication interface. See section 8.2 of this manual for additional information on reprogramming the gauge parameters. The list of parameters that must be reprogrammed is as follows.

- Number of float/number of RTD's
- RTD position(s)
- Gradient
- Float zero positions (2)
- Firmware control code #1
- Hardware control code #1
- Reference magnet position (see paragraph below)

After all of the above gauge parameters have been reprogrammed, the user must execute a special firmware command (command 5E hex) to establish the DDA reference magnet position. The reference magnet position data is used by the firmware during level processing to remove any temperature dependence on the output level information. The reference position data is automatically measured and stored in the EEPROM upon execution of command 5E hex. No additional data input is required. See sections 8.2 and 10.3 for additional information on the programming of the reference magnet position data.

10 HARDWARE/SOFTWARE ENVIRONMENT

The DDA gauge is based on an intrinsically safe EIA-485 network allowing up to 20 gauges to be multi-dropped on one communication line. The network requires a 4-wire interface to provide both power and communications to each of the gauges located in the hazardous area. The gauges are connected in a multi-point configuration as shown in figure 10.1.

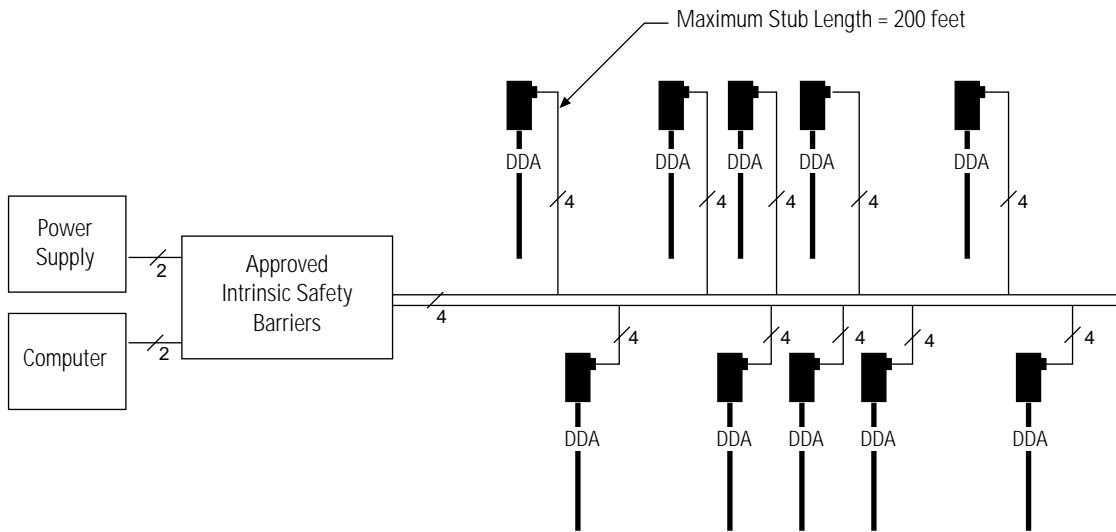

Figure 10.1 DDA Network

The EIA-485 network operates in a master/slave mode where the master (host computer or similar type network controller) interrogates each slave (DDA gauge) for a specific type of data. Each slave has a unique switch programmable hardware address that is issued by the host computer to activate a particular gauge. In addition, the DDA hardware supports a command decoder that supports up to 128 different commands. The host computer interrogates a gauge for data by sending an address byte, followed immediately by a command byte. The addressed gauge will “wake up”, identify itself by transmitting an echo of its own local address followed by the received command, and then perform the requested action. After the requested action has been completed, the data (if any) will be transmitted back to the host computer on the EIA-485 network.

NOTE

This is a 2-wire differential communication interface and all data transmissions must be half-duplex. Only one device (the master or one gauge) can transmit data at any given time. All communications are limited to 4800 baud only.

The serial communication protocol is based on a standard asynchronous serial data transmission format. All words are transmitted serially as 11 bits. Each word begins with a start bit, followed by 8 data bits (bit D1 transmitted first), an even parity bit and one stop bit. See example 1.

Example 1 - Serial data transmission format

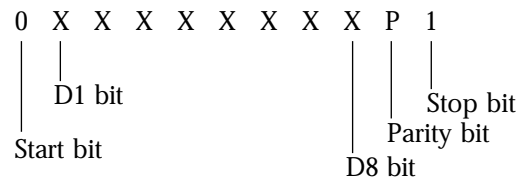

(11 bit total word size)

After the DDA address decoder circuitry receives the 11 bit word, an even parity check is performed across the 8-bit data field. If a parity error is found, the word is ignored and the decoder circuitry resets for the next transmission. If the parity check is good, the decoder circuitry checks for a valid address byte. The address decoder circuitry uses the D8 bit to distinguish the difference between address bytes and command bytes. Address bytes are defined as having the most significant bit (D8) set equal to one. Valid address byte values include C0 hex to FD hex (192 to 253 decimal). Address byte values from 80 hex to BF hex are reserved for future use, address byte values FE and FF hex are reserved for test functions. See example 2.

Example 2 - Address byte

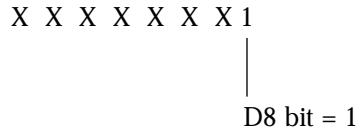

(8 bit word - shown as D1 bit on left)

If the received address byte matches the local DDA address, the DDA power supply circuitry is activated. If a valid address byte has been found, the decoder circuitry checks to see if the next received word is a command byte. Valid command byte values include 00 hex to 7F hex (0 to 127 decimal). In addition, all data byte values are restricted to be within 00 hex and 7F hex. See example 3.

Example 3 - Command byte (and data bytes)

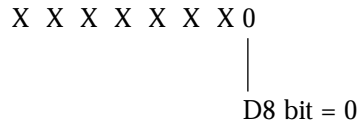

(8 bit word - shown as D1 bit on left)

Again, an even parity check is performed on the command byte. If the parity check is good, the eight bit data word is latched into a command buffer. This buffer is read by the DDA software to determine which command to execute. If the parity check fails, the command byte is rejected and the old command (from the previous interrogation sequence) will be left in the command buffer. The DDA hardware cannot determine if the current command was possibly rejected. The host computer must then verify if the correct command was received by reading the echo of the address byte and command byte sent by the DDA gauge. This is the only guaranteed way to determine that both the address and command bytes were received properly.

This method also insures proper verification, even if the parity check fails to detect a multiple bit data error in either the address byte or command byte. If the host computer determines that either the address byte or command byte has been corrupted, it must wait the proper time-out period and ignore the received message from the DDA gauge that was improperly interrogated. The time-out period is variable and is based on the duration of the selected DDA command.

10.1 DDA/Host Computer Communication Protocol

The DDA/Host computer communication protocol consists of two parts: the interrogation sequence generated by the host computer and the data response generated by the interrogated DDA gauge. The host interrogation sequence always consists of an address byte followed immediately by a command byte.

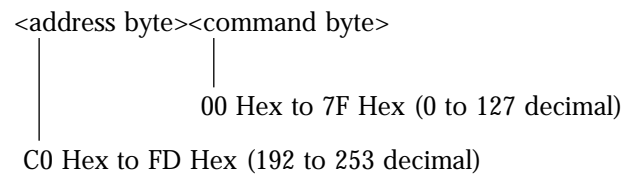

The maximum delay between the address byte and the command byte is 5 milliseconds. The DDA gauge will not receive the new command byte if this delay period is exceeded (and the old command byte will be left in the command buffer). See previous section for additional information on verification of the address/command bytes. An example of an interrogation sequence to access a gauge programmed for address F0 hex is shown below.

Example 4 - Interrogation data sequence

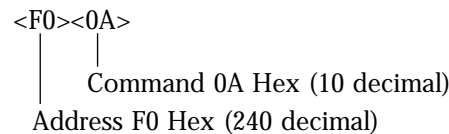

The gauge response consists of several components. After a gauge has been interrogated, the gauge first responds by transmitting its own local address and the command that was received from the host computer. This re-transmission of the gauge address and received command serves two purposes. The first being a simple identification that the correct gauge received the correct command and that it is currently active. The second purpose is to reset the DDA address/command decoder circuitry for the next interrogation sequence.

NOTE

If the DDA gauge does not respond to the first interrogation by the host, the address/command decoder will be left in an intermediate state. If this occurs, the host will have to re-interrogate the respective gauge to reset the address/command decoder circuitry and then interrogate the respective gauge again to perform a new gauge measurement. This hardware feature must be considered when writing software communication drivers to access DDA gauge data.

After the DDA gauge has retransmitted its local address and received command, it will perform the

requested measurement as defined by the received command. After the requested measurement has been completed, the data for that measurement will be transmitted to the host in a predefined format including certain control characters. The DDA transmitted data format begins with a “start of text” character (STX = 02 hex). The STX character is immediately followed by the requested data and then terminated with an “end of text” character (ETX = 03 hex). Certain commands allow multiple data fields to be transmitted within one transmitted data sequence. For these data transmissions, each data field is separated by an ASCII “colon” character (: = 3A hex). See examples below.

Example 5 - Single field data transmission

<STX><dddd.ddd><ETX>

Example 6 - Multiple field data transmission

<STX><dddd.ddd:dddd.ddd:dddd.ddd><ETX>

All transmitted data will consist of 7-bit ASCII characters limited to hex values between 00 hex and 7F hex (i.e. data bit D8 = 0).

After a DDA gauge has completed a data transmission, the host must wait 50 milliseconds before another interrogation can be performed. This delay is required to enable the previously interrogated gauge to go into sleep mode and release the network communication lines.

All DDA control commands support a checksum calculation function (DED - Data Error Detection) that allows the host computer (MASTER) to check the integrity of the transmitted data. The actual checksum value that is transmitted is the compliment (2's compliment) of the calculated value. The checksum scheme is based on a 16 bit summation of the hex data within the transmitted block (including the STX and ETX characters) without regard to overflow. The two byte result of the adding process is then complimented and appended to the transmitted data block. This compliment process makes the final checksum comparison more efficient in that the checksum result added to its compliment will always result in a zero sum for uncorrupted data transmissions. Checksum data (two hex bytes) can range from 0000 hex to FFFF hex. Since the communication network only allows transmitted data values between 00 and 7F hex, special processing is required on the hex checksum value before it can be transmitted.

This two byte hex value must first be converted to numeric (decimal) ASCII characters before transmission. For example, a checksum value of FFFF hex would be transmitted as ASCII 65535. The host computer would then have to convert ASCII 65535 back to hex and perform its own checksum calculation and comparison for the received data from the DDA gauge. An example of a single field data transmission including checksum data and an example checksum calculation are shown below.

Example 7 - Single field data transmission including checksum data

<STX><dddd.ddd><ETX><ccccc>

Appended checksum value

NOTE

The appended checksum value will always consist of five decimal (ASCII) characters ranging from 00000 to 65535. The checksum function can be enabled or disabled with the switch located on the digital printed circuit card. See Section 8.1 of this document for additional information.

Example 8 - Checksum calculation example

Message transmitted from DDA gauge (command 12 Hex):

<STX><265.322:109.456><ETX>64760

Hex character equivalent of transmitted data record including <STX> and <ETX> characters:

02, 32, 36, 35, 2E, 33, 32, 32, 3A, 31, 30, 39, 2E, 34, 35, 36, 03

Two byte Hex summation of data: 0308 Hex

Two's compliment: FCF8 Hex

Convert to decimal ASCII: 64760

To verify transmitted data from the DDA gauge, perform the two byte Hex summation over the data record (including <STX> and <ETX>) as shown above. The result in this example is 0308 Hex. Then convert the decimal ASCII checksum value back to Hex (i.e. 64760 to FCF8 Hex). Add the Hex summation value to the Hex checksum value and the result will be zero (disregarding overflow) for uncorrupted data.

0308 Hex + FCF8 Hex = 0000 Hex

NOTE

CRC (Cyclic Redundancy Check) error checking will be offered at a later date. A command switch will be defined that will let the DDA data be transmitted with CRC error checking instead of checksum error checking. The checksum calculations will use the CRC-CCITT defined polynomial with a 16 bit CRC result. This 16 bit CRC value will be appended to each transmitted message. Since the communication network only allows transmitted data values between 00 and 7F hex, special processing is required on the 16 bit hex CRC value before it can be transmitted. This 16 bit (two byte) hex value must first be converted to numeric (decimal) ASCII characters before transmission. For example, a checksum value of FFFF hex would be transmitted as ASCII 65535.

10.2 Network Protocol/Timing Considerations

The DDA network has several timing constraints that must be considered when designing and coding communication drivers. The DDA network follows the EIA-485 standard which defines a multi-drop communication interface that uses differential drivers and receivers operating in half-duplex mode. In this configuration each device's driver and receiver are wired together as shown in figure 10.2.

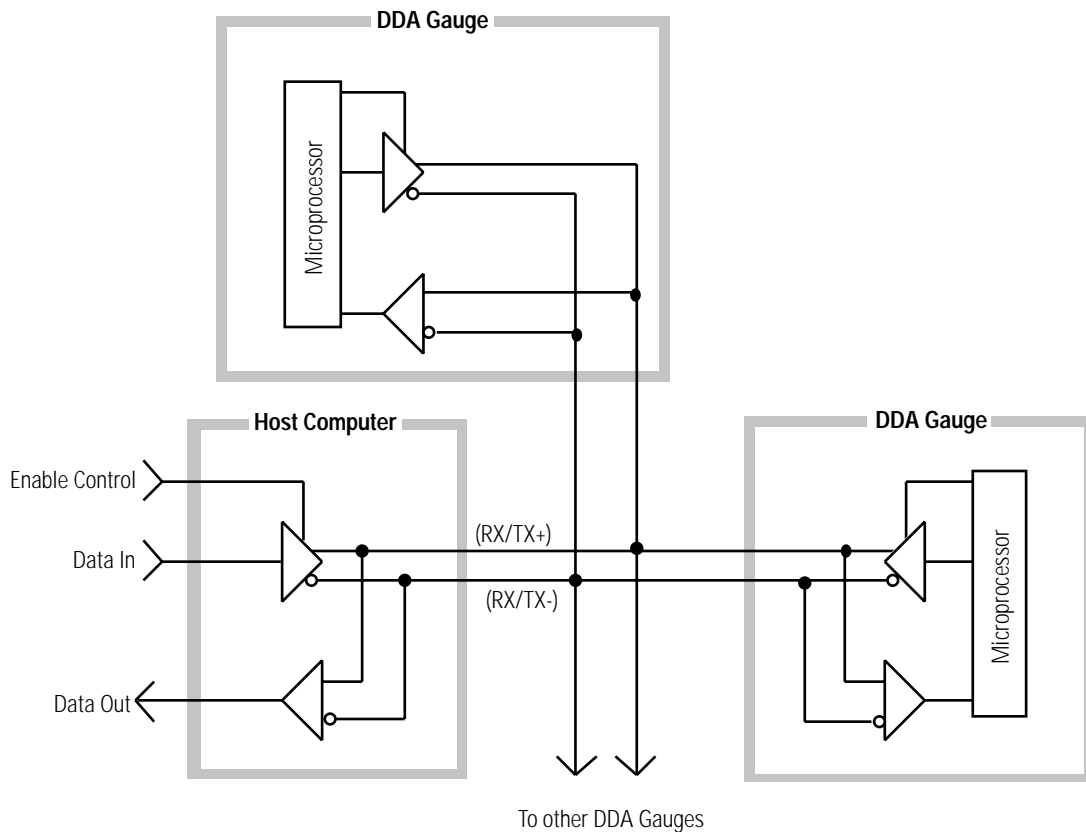

Figure 10.2 EIA-485 multi-drop example

This requires that the driver in each device on the network be disabled (high impedance) except when that device is ready to transmit data. In order to keep devices from transmitting data at the same time, one device is selected as the host (or master). For the DDA network, the host computer (or other communication interface) is the master, and controls the communication timing and protocol. The DDA gauges act as slave devices, only transmitting data when requested by the host computer device. In this fashion, the host computer enables its driver and transmits the address/command interrogation sequence. After the address/command has been completely transmitted, the host disables its driver to allow reception of the data from the DDA gauge. The gauge with the matching address then becomes active, enables its driver and transmits the address/command echo followed by the requested data. The gauge then disables its driver and goes back into sleep mode. Since all devices operate independently, certain timing constraints are imposed on the protocol to eliminate multiple devices from transmitting data simultaneously.

NOTE

Many available communication cards (line drivers) for use with the host computer device use a special control line input to control the enabling and disabling of the EIA-485 driver. Typically this input is connected to the computers RTS or DTR communication port control line. The computer can then control the state of the driver by toggling the RTS or DTR signal lines via software control. An example of this control method is shown in the next section. Other control methods are also used depending on the manufacturer of the equipment.

The network protocol timing sequences are shown below in figure 10.3. This time line representation of data transmission sequences also provides information about host computer control of the EIA-485 communication card. This example shows driver enable control via the RTS control line.

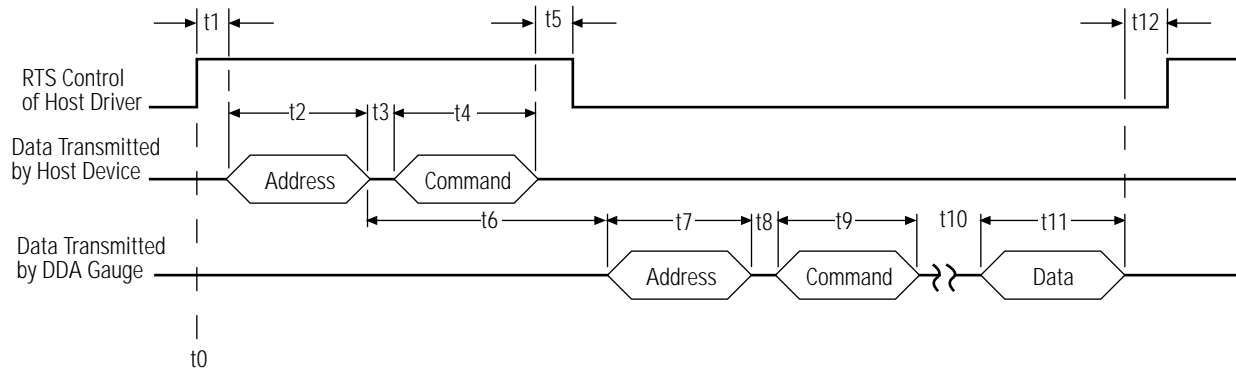

Figure 10.3 Network Protocol Timing Information

An example interrogation sequence is described below (refer to figure 10.3 above).

1. The start of the sequence begins when the host enables its EIA-485 driver to transmit the address/command bytes. This is shown on the timeline as T0. In this example, the host enables the driver by raising the RTS control line of the computer communication port.
2. After the driver is enabled, the host performs a small time delay (T1) to let the communication lines transition from the high impedance state to the active (enabled) state. This typically requires no more than 1 millisecond. If the communication lines are extremely long, additional time may be required due to the additional capacitance of the wires.
3. The host then transmits the address byte followed immediately by the command byte. For 4800 baud transmission rates, the time to transmit one byte (11 bit word size) is fixed at 2.3 milliseconds. Then time delays T2 and T4 are fixed at 2.3 milliseconds. Time delay T3 is the interbyte transmission time. Normally this is at least one bit time (0.21 milliseconds @ 4800 baud) which is controlled by the computer communication hardware. Sometimes software overhead can extend this delay. The maximum permissible delay for period T3 is 5 milliseconds. Then the total maximum delay for periods T2, T3, and T4 is 9.6 milliseconds.
4. After the host transmits the address and command bytes, it must then disable its driver to allow the gauge to transmit the address/command echo and the requested data. Before the driver is disabled, the software must insure that the command byte has been completely transmitted. This can be done by observing control flags from UART of the communication port, such as Transmit Register Empty (TRE) and Transmit Holding Register Empty (if the UART is double buffered). Software delay methods based on maximum character transmission times for 4800 baud rates can also be used but are less reliable. Once it has been verified that the command byte has been completely transmitted, an additional delay should be added before the driver is disabled. This delay (T5) will insure that the data has propagated the network wiring before the driver goes to the high impedance (disabled) state. A delay period of T5 = 1 millisecond is adequate for most long cable runs. The maximum delay allowed for T5 is based on the fact that time period T6 is fixed in the DDA hardware to be 22 (+/- 2) milliseconds. The host driver should be disabled well before (at least 5 milliseconds) the DDA gauge enables its driver and begins transmission of the address/command echo. Assuming the maximum delay of 5 milliseconds for period T3, and 2.3 milliseconds for T4, and that the host driver should be disabled for 5 milliseconds before the gauge begins transmitting data, the maximum delay for T5 then is 7.7 milliseconds.

NOTE

If T3 is less than 5 milliseconds, then the maximum delay for T5 can be extended by the difference (5 milliseconds - T3 actual).

5. The gauge will begin to transmit the address/command echo in 22 (+/- 2) milliseconds after the address byte is received from the host computer. This is defined as period T6 and is fixed by the DDA hardware. Based on a baud rate of 4800, the address echo is transmitted in 2.3 milliseconds (period T7). The interbyte delay period (T8) for the DDA gauge is fixed at 0.1 milliseconds and the command echo is transmitted in 2.3 milliseconds (period T9).
6. Period T10 is the time required for the DDA electronics to perform the requested command. This is a variable delay based on the command requested. The typical gauge response time for each command is listed in the DDA command section of this manual (section 10.3).
7. Period T11 is the time required for the DDA electronics to transmit the data for the requested command. This is a variable delay based on the command requested. The typical data transmission time for each command is listed in the DDA command section of this manual (section 10.3).
8. After the gauge has completed the data transmission for the requested command, it will disable its driver and go back to inactive mode. The gauge electronics require 50 milliseconds to transition from active mode to inactive mode. Another gauge (or the same gauge) cannot be interrogated until time period T12 = 50 milliseconds has elapsed.
9. Repeat the sequence for the next gauge.

Other protocol considerations

1. The transmitted ASCII data from the DDA gauge may contain data fields with Exxx error codes. All DDA error codes are preceded by ASCII 'E' (45 Hex, 69 decimal). Communication interface drivers must parse and handle DDA error codes properly or data processing errors could result. See section 10.3 for additional information about DDA error codes.
2. If a DDA gauge fails to respond to an interrogation from the host device, the DDA address/command decoder circuitry may be left in an intermediate state. Normally the address/command echo from the DDA microprocessor resets the gauge decoder circuitry. If the gauge fails to echo the address/command bytes, then it would be the next address/command byte interrogation from the host device that would reset the decoder circuitry. Consequently the gauge will not respond to the second address/command transmission from the host device. This protocol feature should be considered when adding retry functions to DDA communication interface drivers.
3. Use the DDA 'Data Error Detection' function to verify the integrity of the data transmitted from the gauge.
4. Certain EIA-485 communication cards (and EIA-232 to EIA-485 converter cards) allow user control of the receiver function. This feature must be considered when developing communication drivers. Due to the half-duplex EIA-485 loopback wire connections, all data that is transmitted by the host computer device will be "echoed" into the receiver inputs. If the receiver function is enabled, then the host transmitted data along with the DDA gauge transmitted data will be received into the computer receive buffer.
5. A good protocol technique is to read the RTDs with a slower rate than the level(s). This will avoid a self-heating effect (due to the current that flows through the RTDs elements) and also the gauge response will be much faster (the gauge response time is different to read levels and temperatures). We suggest to use this 'time slicing' technique reading the level(s) continuously and the RTDs using a rate of 30-60 sec. or more.

10.3 DDA Command Definitions (including protocol information)

Special Control Commands

Command 00 Hex (0 Dec) - Gauge disable command.

This command can be used to disable an active gauge (force gauge back to sleep mode). This command does not need to be preceded by an address byte and can only be issued when DDA gauges are not transmitting data. This “disable” command is typically used with other commands that could leave the gauge in active mode, i.e. certain memory transfer commands, test mode commands, etc.

NOTE

During normal mode operation, a DDA gauge will force itself back into sleep mode if any data is transmitted on the network by any other device. This is a safety feature added to the firmware to avoid data collisions on the network.

Command 01 Hex (1 Dec): Module identification command
Data Format: <STX><DDA><ETX><cccc>
• Fixed length record containing 3 ASCII characters “DDA”.
• Five (5) character checksum appended after ETX character.
TA = TB: 95 milliseconds
TC: 23 milliseconds

Command 02 Hex - Command Hex 09 - Not Defined

Level Commands

Command 0A Hex (10 Dec): Output level 1 (product) at 0.1 inch resolution (with checksum)
Data Format: <STX><dddd.d><ETX><cccc>
• Variable length record with one (1) to four (4) characters to the left of decimal character.
• Fixed at one (1) character to the right of decimal character.
• Five (5) character checksum appended after ETX character.
TA: 270 milliseconds
TB: 420 milliseconds
TC: 30 milliseconds

NOTE

<cccc> Checksum characters are only appended if the Data Error Detection (DED) function is enabled. See DDA Gauge Setup Section 8 for additional information about the DED function.

NOTE

The typical gauge response time is defined as the time it takes for the gauge to measure and calculate the requested data. The period begins after the gauge has transmitted the address/command echo and ends when the gauge begins to transmit the requested data (See time reference t10 in Figure 10.3). The typical data transmission time is the time it takes the gauge to transmit the requested data. This time is based on the number of characters transmitted multiplied by 2.3 milliseconds per character (i.e. 4800 baud. See time reference t11 in figure 10.3). See section 10.2 of this document for additional information about gauge response times.

TA = typical gauge response time for style D7, D8, D9 gauges.

TB = typical gauge response time for style LD, LDF gauges.

TC = typical data transmission time (includes checksum).

NOTE

Data characters can include:

- 0 through 9
- (-) minus sign
- (.) decimal point
- (E) ASCII 45 Hex precedes all error codes
- (:) ASCII 3A Hex is used as a data field separator for multiple data field transmissions
- (space) ASCII 20 Hex space character

Command 0B Hex (11 Dec):	Output level 1 (product) at 0.01 inch resolution (with checksum)
Data Format:	<STX><dddd.dd><ETX><ccccc>
	<ul style="list-style-type: none"> • Variable length record with one (1) to four (4) characters to the left of decimal character. • Fixed at two (2) characters to the right of decimal character. • Five (5) character checksum appended after ETX character.
TA:	430 milliseconds
TB:	700 milliseconds
TC:	32 milliseconds
Command 0C Hex (12 Dec):	Output level 1 (product) at 0.001 inch resolution (with checksum)
Data Format:	<STX><dddd.ddd><ETX><ccccc>
	<ul style="list-style-type: none"> • Variable length record with one (1) to four (4) characters to the left of decimal character. • Fixed at three (3) characters to the right of decimal character. • Five (5) character checksum appended after ETX character.
TA:	1.28 seconds
TB:	2.16 seconds
TC:	35 milliseconds

- Command 0D Hex (13 Dec): Output level 2 (interface) at 0.1 inch resolution (with checksum)
 Data Format, TA, TB, TC: Same as Command 0A
- Command 0E Hex (14 Dec): Output level 2 (interface) at 0.01 inch resolution (with checksum)
 Data Format, TA, TB, TC: Same as Command 0B
- Command 0F Hex (15 Dec): Output level 2 (interface) at 0.001 inch resolution (with checksum)
 Data Format, TA, TB, TC: Same as Command 0C
- Command 10 Hex (16 Dec): Output level 1 (product) and level 2 (interface) at 0.1 inch resolution (with checksum)
 Data Format: <STX><dddd.d:dddd.d><ETX><cccc>
- Variable length record with one (1) to four (4) characters to the left of each decimal character in each data field.
 - Fixed at one character to the right of each decimal character in each data field.
 - Level 1, level 2 data fields separated by ASCII colon (:) character.
 - Five (5) character checksum appended after ETX character.
- TA: 350 milliseconds
 TB: 530 milliseconds
 TC: 46 milliseconds
- Command 11 Hex (17 Dec): Output level 1 (product) and level 2 (interface) at 0.01 inch resolution (with checksum)
 Data Format: <STX><dddd.dd:dddd.dd><ETX><cccc>
- Variable length record with one (1) to four (4) characters to the left of each decimal character in each data field.
 - Fixed at two (2) characters to the right of each decimal character in each data field.
 - Level 1, level 2 data fields separated by ASCII colon (:) character.
 - Five (5) character checksum appended after ETX character.
- TA: 600 milliseconds
 TB: 970 milliseconds
 TC: 51 milliseconds

Command 12 Hex (18 Dec): Output level 1 (product) and level 2 (interface) at 0.001 inch resolution (with checksum)

Data Format: <STX><dddd.ddd:dddd.ddd><ETX><ccccc>

- Variable length record with one (1) to four (4) characters to the left of each decimal character in each data field.
- Fixed at three (3) characters to the right of each decimal character in each data field.
- Level 1, level 2 data fields separated by ASCII colon (:) character.
- Five (5) character checksum appended after ETX character.

TA: 1.88 seconds
 TB: 3.20 seconds
 TC: 55 milliseconds

Command 13 Hex - Command 18 Hex - Not Defined

Temperature Commands

Command 19 Hex (25 Dec): Average Temperature at 1.0 degree F resolution (with checksum)

NOTE

Average temperature is the average temperature reading from all RTDs submerged by approximately 1.5 inches of product.

Data Format: <STX><dddd><ETX><ccccc>

- Variable length record with one (1) to four (4) characters.
- Five (5) character checksum appended after ETX character.

TA = TB: 1.0 second + 0.9 seconds per RTD
 TC: 25 milliseconds

Command 1A Hex (26 Dec): Average temperature at 0.2 degree F resolution (with checksum)

Data Format: <STX><dddd.d><ETX><ccccc>

- Variable length record with one (1) to four (4) characters to the left of decimal character.
- Fixed at one (1) character to the right of decimal character.
- Five (5) character checksum appended after ETX character.

TA = TB: 1.7 seconds + 1.6 seconds per RTD
 TC: 30 milliseconds

Command 1B Hex (27 Dec):	Average temperature at 0.02 degree F resolution (with checksum)
Data Format:	<STX><dddd.dd><ETX><cccc> <ul style="list-style-type: none"> • Variable length record with one (1) to four (4) characters to the left of decimal character. • Fixed at two characters to the right of decimal character. • Five (5) character checksum appended after ETX character.
TA = TB:	2.9 seconds + 2.7 seconds per RTD
TC:	32 milliseconds
Command 1C Hex (28 Dec):	Individual RTD temperature at 1.0 degree F resolution (with checksum)
Data Format:	<STX><dddd:dddd:dddd:dddd:dddd><ETX><cccc> <ul style="list-style-type: none"> • Variable length record with one (1) to four (4) characters in each data field. • Variable number of data fields (up to 5) separated by ASCII colon (:) characters. Number of data fields is based on the number of RTDs programmed in DDA gauge memory. • First data field is always RTD #1, second data field is RTD #2, ... etc. • Five (5) character checksum appended after ETX character.
TA = TB:	0.7 seconds + 0.9 seconds per RTD
TC:	71 milliseconds maximum (if using 5 RTDs)
Command 1D Hex (29 Dec):	Individual RTD temperature at 0.2 degree F resolution (with checksum)
Data Format:	<STX><dddd.d:dddd.d:dddd.d:dddd.d:dddd.d><ETX><cccc> <ul style="list-style-type: none"> • Variable length record with one (1) to four (4) characters to the left of decimal character in each data field. • Fixed at one (1) character to the right of each decimal character in each data field. • Variable number of data fields (up to 5) separated by ASCII colon (:) characters. Number of data fields is based on the number of RTDs programmed in DDA gauge memory. • First data field is always RTD #1, second data field is RTD #2,...etc. • Five (5) character checksum appended after ETX character.
TA = TB:	1.4 seconds + 1.6 seconds per RTD
TC:	94 milliseconds maximum (if using 5 RTDs)

Command 1E Hex (30 Dec): Individual RTD temperature at 0.02 degree F resolution (with checksum)

Data Format: <STX><dddd.dd:dddd.dd:dddd.dd:dddd.dd:dddd.dd><ETX><cccc>

- Variable length record with one (1) to four (4) characters to the left of decimal character in each data field.
- Fixed at two (2) characters to the right of each decimal character in each data field.
- Variable number of data fields (up to 5) separated by ASCII colon (:) characters. Number of data fields is based on the number of RTDs programmed in DDA gauge memory.
- First data field is always RTD #1, second data field is RTD #2,...etc.
- Five (5) character checksum appended after ETX character.

TA = TB: 2.6 seconds + 2.7 seconds per RTD

TC: 106 milliseconds maximum (if using 5 RTDs)

NOTE

High resolution (0.02°F) temperatures commands can cause slight errors in the output data due to self-heating effects in the temperature measurement circuitry. The worst case error is 0.10 degrees Fahrenheit for immediately repeated interrogations. Temperature measurement errors due to self-heating effects can be minimized (to less than 0.02 degrees F) by allowing one minute or longer between temperature interrogations.

Command 1F Hex (31 Dec): Average and individual RTD temperature at 1.0 degree F resolution (with checksum).

Data Format: <STX><dddd:dddd:dddd:dddd><ETX><cccc>

- Variable length record with one (1) to four (4) characters in each data field.
- Variable number of data fields (up to 6) separated by ASCII colon (:) characters. The number of data fields is based on the number of RTD's programmed in DDA gauge memory (number of RTD's + 1).
- The first data field is always the average of the individual RTD's submerged by at least 1.5 inches of product.
- The second data field is always RTD #1, third data field is RTD #2, ... etc.
- Five (5) character checksum appended after ETX character.

TA = TB: 0.8 seconds + 0.9 seconds per RTD

TC: 83 milliseconds maximum (if using 5 RTD's)

Command 20 Hex (32 Dec): Average and individual RTD temperature at 0.2 degree F resolution (with checksum).

Data Format: <STX><dddd.d:dddd.d:dddd.d:dddd.d:dddd.d:dddd.d><ETX><cccc>

- Variable length record with one (1) to four (4) characters to the left of decimal character in each data field.
- Fixed at one (1) character to the right of each decimal character in each data field.
- Variable number of data fields (up to 6) separated by ASCII colon (:) characters. The number of data fields is based on the number of RTD's programmed in DDA gauge memory (number of RTD's + 1).
- The first data field is always the average of the individual RTD's submerged by at least 1.5 inches of product.
- The second data field is always RTD #1, third data field is RTD #2, ... etc.
- Five (5) character checksum appended after ETX character.

TA = TB: 1.6 seconds + 1.6 seconds per RTD

TC: 110 milliseconds maximum (if using 5 RTD's)

Command 21 Hex (33 Dec): Average and individual RTD temperature at 0.02 degree F resolution (with checksum).

Data Format: <STX><dddd.dd:dddd.dd:dddd.dd:dddd.dd:dddd.dd:dddd.dd><ETX><cccc>

- Variable length record with one (1) to four (4) characters to the left of decimal character in each data field.
- Fixed at two (2) characters to the right of each decimal character in each data field.
- Variable number of data fields (up to 6) separated by ASCII colon (:) characters. The number of data fields is based on the number of RTD's programmed in DDA gauge memory (number of RTD's + 1).
- The first data field is always the average of the individual RTD's submerged by at least 1.5 inches of product.
- The second data field is always RTD #1, third data field is RTD #2, ... etc.
- Five (5) character checksum appended after ETX character.

TA = TB: 2.8 seconds + 2.7 seconds per RTD

TC: 125 milliseconds maximum (if using 5 RTD's)

Command 22 Hex - Command 24 Hex - Reserved

Command 25 Hex (37 Dec): Fast average and individual RTD temperature at 1.0 degree F resolution (with checksum)

Data Format: Same as command 1F Hex

TA = TB: 0.5 seconds + 0.3 seconds per RTD

TC: 83 milliseconds maximum (if using 5 RTD's)

Command 26 Hex - Command 27 Hex - Not defined

Multiple Output Commands (Level and Temperature)

- Command 28 Hex (40 Dec): Level 1 (product) at 0.1 inch resolution, and average temperature at 1.0 degree F resolution (with checksum)
- Data Format: <STX><dddd.d:dddd><ETX><cccc>
- Variable length record with one (1) to four (4) characters to the left of decimal character in first data field.
 - Fixed at one(1) character to the right of decimal character in first data field.
 - Variable length record with one (1) to four (4) characters in second data field.
 - Level 1 temperature data fields separated by ASCII colon (:) character.
 - Five (5) character checksum appended after ETX character.
- TA: 1.1 seconds + 0.9 seconds per RTD
TB: 1.2 seconds + 0.9 seconds per RTD
TC: 41 milliseconds
- Command 29 Hex (41 Dec): Level 1 (product) at 0.01 inch resolution, and average temperature at 0.2 degree F resolution (with checksum)
- Data Format: <STX><dddd.dd:dddd.d><ETX><cccc>
- Variable length record with one (1) to four (4) characters to the left of decimal character in first data field.
 - Fixed at two (2) characters to the right of decimal character in first data field.
 - Variable length record with one (1) to four (4) characters to the left of decimal character in second data field
 - Fixed at one (1) character to the right of decimal character in second data field.
 - Level 1, temperature data fields separated by ASCII colon (:) character.
 - Five (5) character checksum appended after ETX character
- TA: 2.0 seconds + 1.6 seconds per RTD
TB: 2.2 seconds + 1.6 seconds per RTD
TC: 48 milliseconds
- Command 2A Hex (42 Dec): Level 1 (product) at 0.001 inch resolution, and average temperature at 0.02 degree F resolution (with checksum)
- Data Format: <STX><dddd.ddd:dddd.dd><ETX><cccc>
- Variable length record with one (1) to four (4) characters to the left of decimal character in first data field.
 - Fixed at three (3) characters to the right of decimal character in first data field.
 - Variable length record with one (1) to four (4) characters to the left of decimal character in second data field.
 - Fixed at two (2) characters to the right of decimal character in second data field.
 - Level 1, temperature data fields separated by ASCII colon (:) character.
 - Five (5) character checksum appended after ETX character.
- TA: 4.0 seconds + 2.7 seconds per RTD
TB: 4.8 seconds + 2.7 seconds per RTD
TC: 53 milliseconds

Command 2B Hex (43 Dec): Level 1 (product), level 2 (interface) at 0.1 inch resolution, and average temperature at 1.0 degree F resolution (with checksum)

Data Format: <STX><dddd.d:dddd.d:dddd><ETX><ccccc>

- Variable length record with one (1) to four (4) characters to the left of decimal character in first data field.
- Fixed at one (1) character to the right of decimal character in first data field.
- Variable length record with one (1) to four (4) characters to the left of decimal character in second data field.
- Fixed at one (1) character to the right of decimal character in second data field.
- Variable length record with one (1) to four (4) characters in third data field.
- Level 1, level 2, temperature data fields separated by ASCII colon (:) character.
- Five (5) character checksum appended after ETX character.

TA: 1.2 seconds + 0.9 seconds per RTD
TB: 1.3 seconds + 0.9 seconds per RTD
TC: 58 milliseconds

Command 2C Hex (44 Dec): Level 1 (product), level 2 (interface) at 0.01 inch resolution, and average temperature at 0.2 degree F resolution (with checksum)

Data Format: <STX><dddd.dd:dddd.dd:dddd.d><ETX><ccccc>

- Variable length record with one (1) to four (4) characters to the left of decimal character in first data field.
- Fixed at two (2) characters to the right of decimal character in first data field.
- Variable length record with one (1) to four (4) characters to the left of decimal character in second data field.
- Fixed at two (2) characters to the right of decimal character in second data field.
- Variable length record with one (1) to four (4) characters to the left of decimal character in third data field.
- Fixed at one (1) character to the right of decimal character in third data field.
- Level 1, level 2, temperature data fields separated by ASCII colon (:) character.
- Five (5) character checksum appended after ETX character.

TA: 2.0 seconds + 1.6 seconds per RTD
TB: 2.4 seconds + 1.6 seconds per RTD
TC: 67 milliseconds

Command 2D Hex (45Dec): Level 1 (product), level 2 (interface) at 0.001 inch resolution, and average temperature at 0.02 degree F resolution (with checksum)

Data Format: <STX><dddd.ddd:ddd:ddd.dd><ETX><cccc>

- Variable length record with one (1) to four (4) characters to the left of decimal character in first data field.
- Fixed at three (3) characters to the right of decimal character in first data field.
- Variable length record with one (1) to four (4) characters to the left of decimal character in second data field.
- Fixed at three (3) characters to the right of decimal character in second data field.
- Variable length record with one (1) to four (4) characters to the left of decimal character in third data field.
- Fixed at two (2) characters to the right of the decimal character in third data field.
- Level 1, level 2, temperature data fields separated by ASCII colon (:) character.
- Five (5) character checksum appended after ETX character.

TA: 4.6 seconds + 2.7 seconds per RTD
 TB: 5.9 seconds + 2.7 seconds per RTD
 TC: 74 milliseconds

Command 2E Hex - Command 30 Hex - Not Defined

Command 31 Hex - Command 40 Hex - Reserved for factory use

Test Commands

NOTE

DDA test commands consist of two components (or data communication sequences). The first component of any test command consists of the usual <addr><command> data necessary to activate the respective DDA gauge. The second component consists of a special access code for each test command.

Command 41 Hex (65 Dec): RAM Read / Write Test
 Host Issued
 Command (Part 1)
 Data Format: <addr><command>

- “addr” is the DDA gauge address
- “command” is the DDA command 41 Hex
- After the address and command byte have been transmitted by the host, the respective DDA gauge will “wake up” and retransmit (echo) the local DDA address and received command. The DDA gauge will remain active, waiting for the second part of the test command to be issued by the host. If the second part of the test is not received within 1.0 seconds (see note below), or the command is not received in the proper format, the DDA gauge will cancel the current command sequence and go back to sleep mode.

NOTE

The time-out timer function can be enabled or disabled with the switch located on the digital printed circuit card. See Section 8.1 of this document for additional information.

Host Issued
Command (Part 2)

Data Format: <SOH><DDAT1><EOT>

- Fixed length record with one data field
- SOH is ASCII 01 Hex
- The data field consists of five (5) ASCII characters, as shown, where “1” is the actual test command number. All characters must be in uppercase ASCII.
- EOT is ASCII 04 Hex.

TA = TB: 250 milliseconds

NOTE

The typical gauge transmission time (TC) for all test commands (except 47 Hex) will be 14 milliseconds for an <ACK> response and 25 milliseconds for a <NAK> response.

DDA Gauge Response (after test has been completed):

Data Format: <ACK><cccc>

- ACK is ASCII 06 Hex. This character is sent by the DDA gauge to confirm, to the host, that the selected test was completed successfully (i.e. without errors).

DDA Gauge Response (after test has been completed)

Data Format: <NAK><Exxx><ETX><cccc>

- NAK is ASCII 15 Hex. This character is sent by the DDA gauge to confirm, to the host, that the selected test was not completed successfully.
- Exxx is an error code defining the type of error that occurred during the selected test. “E” is ASCII 45 Hex and xxx is numeric ASCII error code ranging from 000 to 999. Certain test commands can generate multiple error codes, where each error code is separated by an ASCII colon (:). See Section 10.4 of this document for further description of DDA error codes.
- ETX is ASCII 03 Hex.
- cccc is five a (5) character checksum appended after ETX character. Value can range from 00000 to 65535.

All DDA test commands adhere to the communication sequence as described above, and consist of the following components:

1. Host issued command (Part 1): <address><command>
2. DDA gauge response: <address><command> echo
3. Host issued command (Part 2): DDATx (including necessary control characters)
4. DDA gauge response: <ACK> or <NAK><Exxx> plus checksum

Descriptions for other DDA test commands will include only the data format for Part 2 of each host issued command.

Command 42 Hex (66 Dec): ROM data checksum test
(Part 2) Host Data Format: <SOH><DDAT2><EOT>
TA = TB: 600 milliseconds

Command 43 Hex (67 Dec): Not Defined

Command 44 Hex (67 Dec): Not defined

Command 45 Hex (69 Dec): Counter Integrity Test (24 bit)
(Part 2) Host Data Format: <SOH><DDAT5><EOT>
TA = TB: 20 milliseconds

Command 46 Hex (70 Dec): Analog Converter Test
(Part 2) Host Data Format: <SOH><DDAT6><EOT>
TA = TB: 150 milliseconds

Command 47 Hex (71 Dec): Communication Hardware Test
(Part 2) Host Data Format: <SOH><DDAT7><EOT>
TA = TB: 20 milliseconds

NOTE

The DDA gauge will output the following 47 characters during this test, followed by a final <ACK> or <NAK><E908><cccc>

*<SOH><STX><ETX><EOT><ENQ><ACK><NAK><AB
CDEFGHIJKLMNOPQRSTUVWXYZ.0123456789:- >*

- Last character is ASCII space (20 Hex)*
- The checksum value is only calculated for the ACK/NAK response*
- TC = 122 milliseconds (includes all echoed characters, <ACK> and checksum)*

Command 48 Hex (72 Dec): Waveguide Driver / Amplifier / Comparator Test
(Part 2) Host Data Format: <SOH><DDAT8><EOT>
TA = TB: 50 milliseconds

Command 49 Hex (73 Dec): Not Defined

Command 4A Hex (74 Dec): Not Defined

High Level Memory Read Commands

Command 4B Hex (75 Dec): Read “number of floats and number of RTDs” control variables
Data Format: <STX><d:d><ETX><cccc>

- Fixed length record with one (1) character in each field.
- The first data field is the number of floats, second data field is the number of RTDs.
- Five (5) character checksum appended after ETX character.

TA = TB: 100 milliseconds
TC: 23 milliseconds

Command 4C Hex (76 Dec): Read “gradient” control variable
Data Format: <STX><d.ddddd><ETX><cccc>

- Fixed length record with seven (7) characters (including decimal point).
- Five (5) character checksum appended after ETX character.

TA = TB: 125 milliseconds
TC: 32 milliseconds

Command 4D Hex (77 Dec): Read float zero position data (float #1 and #2)
Data Format: <STX><dddd.ddd:ddd><ETX><cccc>

- Variable length record with one (1) to four (4) characters to the left of decimal character in first data field. The data may include an ASCII (-) negative sign character (2D Hex) in the first character position.
- Fixed at three (3) characters to the right of decimal character in first data field.
- Variable length record with one (1) to four (4) characters to the left of decimal character in second data field. The data may include an ASCII (-) negative sign character (2D Hex) in the first character position.
- Fixed at three (3) characters to the right of decimal character in second data field.
- Float #1, float #2 data fields separated by ASCII colon (:) character.
- Five (5) character checksum appended after ETX character.

TA = TB: 135 milliseconds
TC: 58 milliseconds

Command 4E Hex (78 Dec): Read RTD position data (RTDs 1 - 5)
 Data Format: <STX><dddd.d:dddd.d:dddd.d:dddd.d:dddd.d><ETX><cccc>

- Variable length record with one (1) to four (4) characters to the left of decimal character in each data field.
- Fixed at one (1) character to the right of decimal character in each data field.
- Variable number of data fields (up to 5) separated by ASCII colon (:) characters. The number of data fields is based on the “number of RTDs” control variable. See command 4B Hex.
- The first data field is always RTD #1, second field is always RTD #2,...etc.
- Five (5) character checksum appended after ETX character.

TA = TB: 200 milliseconds
 TC: 95 milliseconds

NOTE
RTD position data is referenced from the mounting flange of the gauge housing. RTD #1 is the RTD closest to the tip of the gauge.

Command 4F Hex (79 Dec): Read factory serial number data and software version number
 Data Format: <STX><dddddd....dddddd:Vd.ddd><ETX><cccc>

- Fixed length record of 50 characters to the left of the colon character and 6 characters to the right of the colon character (57 total).
- Five character checksum appended after ETX character.

TA = TB: 100 milliseconds
 TC: 147 milliseconds

Command 50 Hex (80 Dec): Read firmware control code #1
 Data Format: <STX><d:d:d:d:d><ETX><cccc>

- Fixed length record with one (1) character in each data field.
- First data field is the control variable for the data error detection (DED) mode.
- The second data field is the control variable for the communication time-out timer (CTT).
- The third data field is the control variable for temperature data units
- The fourth data field is the control variable for linearization enable/disable.
- The fifth data field is the control variable for innage/ullage level output.
- The sixth data field is reserved for future use; the output value for this field is ASCII “0”.
- See write command (5A Hex) for field value assignments
- Five (5) character checksum appended after ETX character.
- See section 8.2 of this document for additional information about the firmware control code.

TA = TB: 100 milliseconds
 TC: 42 milliseconds

Command 51 Hex (81 Dec): Read hardware control code #1
 Data Format: <STX><dddddd><ETX><cccc>

- Fixed length record with six (6) characters.
- The hardware control code controls various functions in the DDA electronic hardware.
- The hardware control code must match the hardware control code stamped on the gauge label; the control code on the label is preceded by “CC” (i.e. CC001122).
- Five (5) character checksum appended after ETX character.
- See section 8.2 of this manual for additional information about the hardware control code.

TA = TB: 100 milliseconds
 TC: 30 milliseconds

Command 52 Hex (82 Dec): Not defined

Command 53 Hex (83 Dec): Reserved for factory use

Command 54 Hex (84 Dec): Not defined

High Level Memory Write Commands

Command 55 Hex (85 Dec): Write “number of floats and number of RTDs” control variables
 Host Issued
 Command (Part 1)
 Data Format: <addr><commands>

- addr is the DDA gauge address
- command is DDA command 55
- After the address and command byte have been transmitted by the host, the respective DDA gauge will “wake up” and retransmit (echo) the local DDA address and received command. The DDA gauge will remain active, waiting for the second part of the memory write command to be issued by the host. If the second part of the memory write command is not received within 1.0 seconds (see note below), or the command is not received in the proper format, the DDA gauge will cancel the current command sequence and go back to sleep mode.

NOTE

The time-out timer function can be enabled or disabled with the switch located on the digital printed circuit card. See Section 8.1 of this document for additional information.

Host Issued
Command (Part 2)

Data Format:

<SOH><d:d><EOT>

- Fixed length record with two (2) data fields.
- SOH is ASCII 01 Hex.
- The first data field contains the “number of floats” value to be written to the “number of floats” control variable. This variable is limited to a value of 1 or 2 (ASCII).
- The second data field contains the “number of RTDs” value to be written to the “number of RTDs” control variable. This variable is limited to a value between 0 and 5 (ASCII).
- ASCII colon (:) is the “number of floats/number of RTDs” field separator.
- EOT is ASCII 04 Hex.

DDA Gauge Response
(verification sequence)

Data Format:

<STX><d:d><ETX><cccc>

- Fixed length record with two (2) data fields.
- STX is ASCII 02 Hex.
- The first data field contains the “number of floats” value to be written to the “number of floats” control variable. This variable is limited to a value of 1 or 2 (ASCII).
- The second data field contains the “number of RTDs” value to be written to the “number of RTDs” control variable. This variable is limited to a value between 0 and 5 (ASCII).
- ASCII colon (:) is the “number of floats/number of RTDs” field separator.
- ETX is ASCII 03 Hex
- cccc is a five (5) character checksum appended after ETX character.

Host Issued
Command (Part 3)

Data Format:

<ENQ>

- ENQ is ASCII 05 Hex. This character is sent by the host to initiate the EEPROM write cycle. After the EEPROM memory locations have been successfully written to, the DDA gauge will respond back to the host with a ACK character signifying the memory write cycle was successful, or with a NAK character signifying the memory write cycle was unsuccessful. See DDA gauge response below.
- The ENQ character must be received within 1.0 seconds or the DDA gauge will cancel the current command and go back to sleep.

NOTE

EEPROM write time is 10 milliseconds per byte. The ACK/NAK response will not be transmitted by the DDA gauge until the memory bytes have been written and verified or a memory write error has caused the DDA gauge to time-out.

DDA Gauge Response:

Data Format: <ACK>

- ACK is ASCII 06 Hex. This character is sent by the DDA gauge to confirm to the host that the EEPROM memory write cycle was completed successfully.

Data Format: <NAK><Exxx><ETX><cccc>

- NAK is ASCII 15 Hex. This character is sent by the DDA gauge to confirm to the host that the EEPROM memory write cycle was not completed successfully.
- Exxx is an error code defining the memory write error that occurred during the EEPROM write cycle. "E" is ASCII 45 Hex and xxx is the numeric ASCII error code ranging from 000 to 999. See Section 10.4 of this document for further description of DDA error codes.
- ETX is ASCII 03 Hex
- ccccc is a five character checksum appended after ETX character. Value can range from 00000 to 65535.

All high level memory write commands adhere to the communication sequence as described above, and consist of the following components:

1. Host issued command (Part 1): <address><command>
2. DDA gauge response: <address><command> echo
3. Host issued command (Part 2): data to be written (including necessary control characters)
4. DDA gauge response: verification sequence
5. Host issued command (Part 3): <ENQ>
6. DDA gauge response: <ACK> or <NAK>

Descriptions for other high level memory write commands will include only the data format for Part 2 of each host issued command.

Command 56 Hex (86 Dec): Write "gradient" control variable

(Part 2) Host Data Format: <SOH><d.ddddd><EOT>

- Fixed length record with one data field.
- SOH is ASCII 01 Hex.
- The fixed length data field contains the "gradient" value to be written to the "gradient" control variable. This variable is limited to a value between 7.00000 and 9.99999 (ASCII).
- EOT is ASCII 04 Hex.

- Command 57 Hex (87 Dec): Write float zero position data (float #1 or #2)
(Part 2) Host Data Format: <SOH><c:dddd.ddd><EOT>
- Variable length record with two (2) data fields.
 - The first data field contains one character that controls which zero position memory location is written to (i.e., float #1 or float #2). This control character is limited to a value of 1 or 2 (ASCII).
 - The second data field contains the “zero position” data value to be written to the “zero position” memory location. This is a variable length data field with one (1) to four (4) characters to the left of the decimal character and fixed at three (3) characters to the right of the decimal character. The data may include the ASCII (-) negative sign character (2D Hex) in the first position. The zero position data is limited to a value between -999.999 and 9999.999 (ASCII).
 - EOT is ASCII 04 Hex

NOTE

Zero position is referenced from the mounting flange of the gauge housing.

- Command 58 Hex (88 Dec): Write float zero position data (float #1 or #2) using DDA calibrate mode.
(Part 2) Host Data Format: <SOH><c:dddd.ddd><EOT>
- Variable length record with two (2) data fields.
 - The first data field contains one character that controls which zero position memory location is written to (i.e., float #1 or float #2). This control character is limited to a value of 1 or 2 (ASCII).
 - The second data field contains the “current float position” data value to be used to calculate the “zero position” value that is to be written to the “zero position” memory location. This is a variable length data field with one (1) to four (4) characters to the left of the decimal character and fixed at three (3) characters to the right of the decimal character. The data may include the ASCII (-) negative sign character (2D Hex) in the first position. The “current float position” data is limited to a value between -999.999 and 9999.999 (ASCII).
 - EOT is ASCII 04 Hex.

Command 59 Hex (89 Dec): Write RTD position data (RTD1-5).

(Part 2) Host Data Format: <SOH><c:dddd.d><EOT>

- Variable length record with two (2) data fields.
- The first data field contains one (1) character that controls which “RTD position” memory location is written to (i.e. RTD position #1, 2, 3, 4 or 5). This control character is limited to a value between 1 and 5 (ASCII).
- The second data field contains the “RTD position” data value to be written to the respective “RTD position” memory location. This is a variable length data field with one (1) to four (4) characters to the left of the decimal character and fixed at one (1) character to the right of the decimal character. The RTD position data is limited to a value between 0.0 and 9999.9 (ASCII).
- EOT is ASCII 04 Hex

NOTE

RTD position data is referenced from the mounting flange of the gauge housing. An RTD position value of 0.0 will cause that RTD to be excluded from the temperature measurement process. This feature can be used to “turn off” open or shorted RTDs. RTD #1 is the RTD closest to the tip of the gauge. Each RTD position can also be set equal to the DDA gauge length to override the average temperature submersion algorithm. Each RTD with the position set equal to (or greater) than the gauge length will always be included in the average temperature calculation.

RTD position data can be found on the gauge label. RTD position data from gauge flange (referenced to) is enclosed in brackets, (i.e. [xx.x]) and shown in inches and tenths.

- Command 5A Hex (90 Dec): Write firmware control code #1
(Part 2) Host Data Format: <SOH><d:d:d:d:d><EOT>
- Fixed length record with one character in each data field.
 - SOH is ASCII 01 Hex.
 - The first data field is the control variable for the data error detection (DED) function. This variable can have a value of 0, 1, or 2. A value of 0 enables the DED function, using a 16 bit checksum calculation. A value of 1 enables the DED function, using a 16 bit CRC calculation. A value of 2 disables the DED function.
 - The second field is the control variable for the communication time-out timer (CTT) function. This variable can have a value of 0 or 1. A value of 0 enables the CTT function, and a value of 1 disables the CTT function.
 - The third data field is the control variable for temperature data units. This variable can have a value of 0 or 1. A value of 0 enables Fahrenheit temperature units. A value of 1 enables Celsius temperature units.
 - The fourth data field is the control variable for linearization control. This variable can have a value of 0 or 1. A value of 0 disables linearization of the level data. A value of 1 enables linearization.
 - The fifth data field is the control variable for innage/ullage level output. This variable can have a value of 0, 1 or 2. A value of 0 enables normal innage level output. A value of 1 enables ullage level output and a value of 2 enables ullage level output with reversed RTD submersion processing. Mode 2 is used for inverted gauge applications where the gauge is installed from the bottom of the tank.
 - The sixth data field is reserved for future use. The data value for this field must be "0" (ASCII 30 Hex).
 - EOT is ASCII 04 Hex.
 - See section 8.2 of this document for additional information about the firmware control code.

NOTE

When the linearization function is enabled, level update time delays will be increased by approximately 200 milliseconds per level variable (level 1 and level 2). Consult factory for information on the use of the DDA linearization function.

Command 5B Hex (91 Dec): Write hardware control code #1
(Part 2) Host Data Format: <SOH><dddddd><EOT>

- Fixed length record with six (6) characters.
- SOH is ASCII 01 Hex.
- The hardware control code controls various functions in the DDA electronic hardware.
- The hardware control code must match the hardware control code stamped on the gauge label. The control code on the label is preceded by "CC" (i.e. CC001122).
- EOT is ASCII 04 Hex.
- See section 8.2 of this document for additional information about the hardware control code.

Command 5C Hex (92 Dec): Not Defined

Command 5D Hex (93 Dec): Reserved for factory use

Command 5E Hex (94 Dec): Write (update) reference magnet position
(Part 2) Host Data Format: <SOH><DDATR><EOT>

- Fixed length record with five (5) ASCII characters, "DDATR".
- SOH is ASCII 01 Hex.
- EOT is ASCII 04 Hex.
- The reference magnet position is automatically measured by the DDA gauge and stored in EEPROM. No data is required.
- See section 8.2 on this document for additional information about this function.

NOTE

Command 5E Hex does not echo the normal DDA memory write verification sequence or require an ENQ control character to initiate the memory write cycle. The ACK/NAK character sequence will be transmitted after the operation has been completed.

Commands 5F Hex - 7F Hex - Reserved for future use

10.4 DDA Error Codes

All error codes are preceded by a capital letter “E” (ASCII 45 hex) and are in the form of Exxx where xxx can be any number from 000 to 999. Error codes can be embedded in any data field within a transmitted record. Certain DDA commands can generate multiple error codes. See examples below.

Command 0A Hex:<STX><Exxx><ETX><cccc>

Command 2D Hex:<STX><Exxx:Exxx:ddd.dd><ETX><cccc>

Command 1E Hex:<STX><E203:dddd.dd:dddd.dd:E207:dddd.dd><ETX><cccc>

E101: Illegal Request for Level Data

A request has been made for level 1 and/or level 2 data with the “number of floats” control variable set equal to zero, or a request has been made for level 2 data with the “number of floats” control variable set equal to one (1).

E102: Missing Float(s) (Level 1 or Level 2)

The number of floats measured by the hardware is less than the “number of floats” control variable.

E103: Hardware Failure

No response detected from the waveguide driver/receiver circuitry.

E104: Linearization error - Table search error (value low)

E105: Linearization error - Table search error (value high)

E106: Linearization error - Illegal data value encountered

E201: No RTDs Programmed

A request for temperature data has been made with the “number of RTDs” control variable set to equal zero (0) or all programmed RTD’s are set inactive (i.e. RTD position data is set equal to zero (0.000)).

E202: No RTDs Submerged

A request for “average” temperature data has been made with none of the programmed RTDs submerged below the product float (level 1).

E203: Temperature Under-range

The selected RTD measurement is below the allowable measurement range.

E204: Temperature Over-range

The selected RTD measurement is above the allowable measurement range.

- E205: Hardware Failure (cannot zero A/D converter)
The analog to digital converter cannot be zeroed.
- E206: Hardware Failure (open calibration resistor - A/D over-range)
The calibration resistor is not connected and/or the analog converter has malfunctioned.
- E207: Open RTD
The indicated RTD is not connected or open (infinite resistance).
- E208: Shorted RTD
The indicated RTD is shorted (low resistance).
- E209: RTD Submersion Check Failed
The RTD submersion check could not be completed due to missing level 1 data (i.e. no response detected from the product float).
- E210: RTD Average Calculation Error
The average temperature could not be calculated due to an individual RTD measurement error. This error is generated if an average temperature calculation has been requested and any of the following errors have been detected: E201, E203, E204, E207, E208.
- E211: Hardware Failure (shorted calibration resistor)
The temperature calibration resistor is shorted.
- E212: RTD Off
The indicated RTD is not active (i.e. RTD position data is set equal to zero (0)).
- E501: EEPROM Memory Write Verification
The requested memory write was unsuccessful due to a readback verification error.
- E901: RAM Read/Write Test Failed
The DDA RAM (random access memory) read/write test has failed.
- E902: ROM Checksum Test Failed
The DDA ROM (read only memory) checksum verification test has failed.
- E903: EEPROM Read/Write Test Failed
The DDA EEPROM (electrically erasable-programmable read only memory) read/write test has failed.

- E905: Counter Integrity Test Failed
The 24-bit digital counter integrity test has failed.
- E906: Analog Converter Test Failed
The analog to digital converter cannot be zeroed.
- E907: Analog Converter Test Failed
The calibration resistor is not connected and/or the analog converter has malfunctioned.
- E908: Communication Hardware Test Failed
The communication driver/receiver hardware has failed. Internal loopback communication was not successful.
- E909: Waveguide Driver/Receiver Hardware Test Failed
The waveguide driver/receiver hardware has failed. No response from the waveguide driver/receiver/comparator circuitry.
- E950: Automatic Gain Set Failed
The amplifier gain variable has been set to the maximum value and no waveguide response can be detected.

APPENDIX A

The following are standards/publications with information on the installation and maintenance of intrinsically safe systems.

Reference Standards

- ANSI/ISA-RP12.6 - Installation of intrinsically safe systems for hazardous locations.
- NFPA 493 - Standard for intrinsically safe apparatus and associated apparatus for use in Class I, II and III, Division 1 hazardous locations.
- NFPA 70 - National Electrical Code, Article 500, Hazardous (classified) locations.
- UL 913 - Intrinsically safe apparatus and associated apparatus for use in Class I, II and III, Division 1, hazardous locations.
- NEC - National Electrical Code, Article 504

Publications

- E.C. Magison - INTRINSIC SAFETY, Instrument Society of America, 1984
- R.J. Redding - INTRINSIC SAFETY, McGraw-Hill, 1971
- L.C. Towle - MAINTENANCE OF ELECTRICAL INSTRUMENTATION IN HAZARDOUS AREAS, Measurement and Control, Vol. 11, 1978
- R. Garside - INTRINSICALLY SAFE INSTRUMENTATION, Instrument Society of America, 1983

APPENDIX B EPROM REPLACEMENT PROCEDURE

1. Make sure all power supplies and computer devices connected to the DDA network are turned OFF.
2. Loosen the six top screws from the cover of the gauge. The cover screws are captive type and will remain in the cover assembly.
3. Remove the cover. If the cover is snug, use a thin bladed screwdriver to separate the cover from the housing. Be careful not to damage the O-ring seal.
4. Remove the DDA digital printed circuit board (PCB) from the gauge housing.
5. Using the proper EPROM extractor tool, replace the DDA digital PCB EPROM with the updated version of the EPROM. See the diagram below for proper location of the EPROM IC. The EPROM is installed in a socket marked "U13". Observe that the EPROM is oriented properly when installing the new EPROM into the socket.

CAUTION

Always use proper techniques when handling static sensitive boards and component.

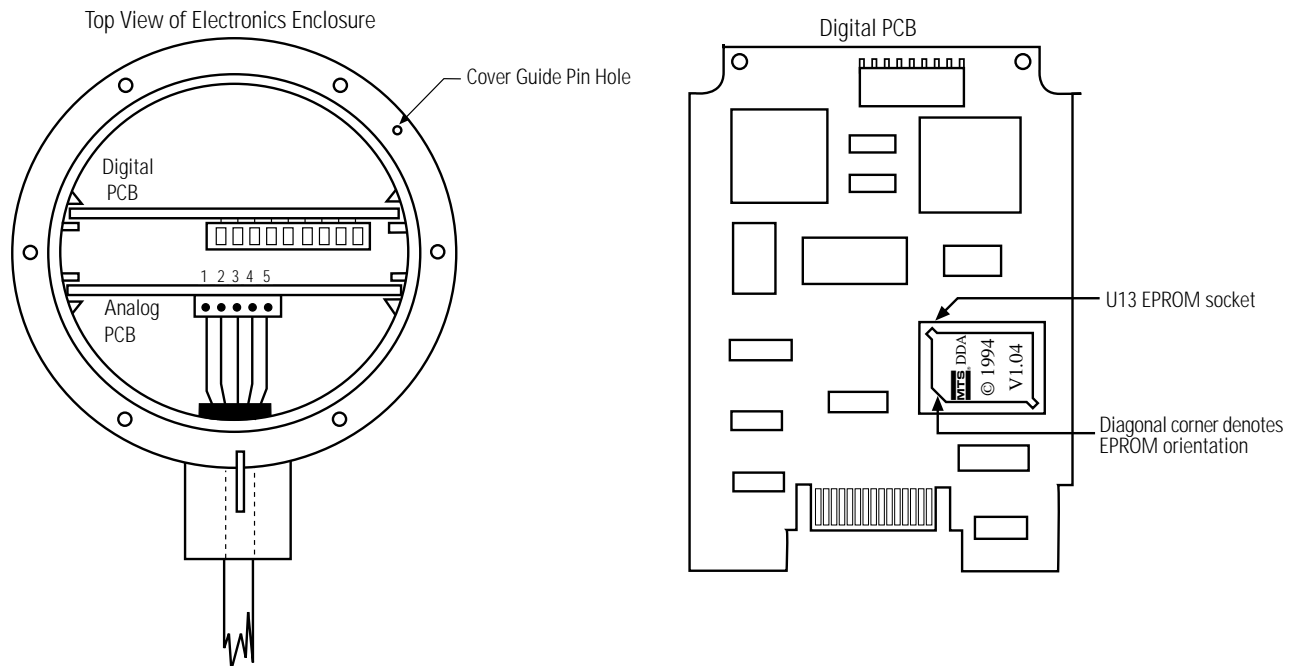

Figure B.1

6. Reinstall the DDA digital PCB into the gauge housing.
7. Install the housing cover and tighten the six cover screws. When re-installing the cover it may be necessary to re-moisten the sealing O-ring with silicone grease. This will keep the O-ring from drying out and sticking to the gauge housing, making the cover hard to remove. Note that the cover has a guide pin that determines the correct cover orientation.
8. Check gauge for proper operation.

APPENDIX C ASCII CHARACTER CODES

DEC	HEX	CHR	CTL	DEC	HEX	CHR	DEC	HEX	CHR
000	00	NUL	@	044	2C	,	088	58	X
001	01	SOH	A	045	2D	-	089	59	Y
002	02	STX	B	046	2E	.	090	5A	Z
003	03	ETX	C	047	2F	/	091	5B	[
004	04	EOT	D	048	30	0	092	5C	\
005	05	ENQ	E	049	31	1	093	5D]
006	06	ACK	F	050	32	2	094	5E	^
007	07	BEL	G	051	33	3	095	5F	_
008	08	BS	H	052	34	4	096	60	`
009	09	HT	I	053	35	5	097	61	a
010	0A	LF	J	054	36	6	098	62	b
011	0B	VT	K	055	37	7	099	63	c
012	0C	FF	L	056	38	8	100	64	d
013	0D	CR	M	057	39	9	101	65	e
014	0E	SO	N	058	3A	:	102	66	f
015	0F	SI	O	059	3B	;	103	67	g
016	10	DLE	P	060	3C	<	104	68	h
017	11	DC1	Q	061	3D	=	105	69	i
018	12	DC2	R	062	3E	>	106	6A	j
019	13	DC3	S	063	3F	?	107	6B	k
020	14	DC4	T	064	40	@	108	6C	l
021	15	NAK	U	065	41	A	109	6D	m
022	16	SYN	V	066	42	B	110	6E	n
023	17	ETB	W	067	43	C	111	6F	o
024	18	CAN	X	068	44	D	112	70	p
025	19	EM	Y	069	45	E	113	71	q
026	1A	SUB	Z	070	46	F	114	72	r
027	1B	ESC	[071	47	G	115	73	s
028	1C	FS	\	072	48	H	116	74	t
029	1D	GS]	073	49	I	117	75	u
030	1E	RS	^	074	4A	J	118	76	v
031	1F	US	-	075	4B	K	119	77	w
032	20	SP		076	4C	L	120	78	x
033	21	!		077	4D	M	121	79	y
034	22	"		078	4E	N	122	7A	z
035	23	#		079	4F	O	123	7B	{
036	24	\$		080	50	P	124	7C	
037	25	%		081	51	Q	125	7D	}
038	26	&		082	52	R	126	7E	~
039	27	'		083	53	S	127	7F	␣
040	28	(084	54	T			
041	29)		085	55	U			
042	2A	*		086	56	V			
043	2B	+		087	57	W			

APPENDIX D COMPLETE ADDRESS DECODING (SWITCHES SETTINGS)

Dec	Hex	Bin	Addr
192	C0	000000	0
193	C1	000001	1
194	C2	000010	2
195	C3	000011	3
196	C4	000100	4
197	C5	000101	5
198	C6	000110	6
199	C7	000111	7
200	C8	001000	8
201	C9	001001	9
202	CA	001010	10
203	CB	001011	11
204	CC	001100	12
205	CD	001101	13
206	CE	001110	14
207	CF	001111	15
208	D0	010000	16
209	D1	010001	17
210	D2	010010	18
211	D3	010011	19
212	D4	010100	20
213	D5	010101	21
214	D6	010110	22
215	D7	010111	23
216	D8	011000	24
217	D9	011001	25
218	DA	011010	26
219	DB	011011	27
220	DC	011100	28
221	DD	011101	29
222	DE	011110	30
223	DF	011111	31

Dec	Hex	Bin	Addr
224	E0	100000	32
225	E1	100001	33
226	E2	100010	34
227	E3	100011	35
228	E4	100100	36
229	E5	100101	37
230	E6	100110	38
231	E7	100111	39
232	E8	101000	40
233	E9	101001	41
234	EA	101010	42
235	EB	101011	43
236	EC	101100	44
237	ED	101101	45
238	EE	101110	46
239	EF	101111	47
240	F0	110000	48
241	F1	110001	49
242	F2	110010	50
243	F3	110011	51
244	F4	110100	52
245	F5	110101	53
246	F6	110110	54
247	F7	110111	55
248	F8	111000	56
249	F9	111001	57
250	FA	111010	58
251	FB	111011	59
252	FC	111100	60
253	FD	111101	61
254	FE	n.a.	62
255	FF	n.a.	63

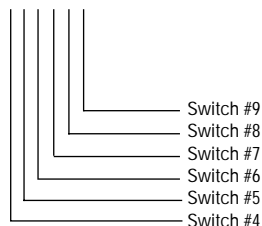

1 = OFF ('Up' position)
0 = ON ('down' position)
n.a. = Not Applicable



MTS System Corporation

Sensors Division
3001 Sheldon Drive
Cary, North Carolina 27513
Telephone: 1-800-457-6620
Fax: 919-677-0200
Internet: www.levelplus.com

Printed in USA ©COPYRIGHT MTS SYSTEMS CORPORATION
8/98 550164 REVISION D

Level Plus is a registered trademark of MTS Systems Corporation
System80 is a trademark of MTS Systems Corporation

MTS Sensor Technologie GmbH and Co. KG

Auf dem Schuffel 9, D-58513 Lüdenschied, Germany
Postfach 8130 D-58489 Lüdenschied, Germany
Phone: +49-2351-95870
Fax: +49-2351-56491

MTS Sensor Technology Corporation

Izumikan Gobancho
12-11 Gobancho
Chiyoda-ku
Tokyo 102
Japan
Phone: +813 3239-3003
Fax: +813 3262-7780

