

Data Sheet

GB-Series with threaded flange SSI

Magnetostrictive Linear Position Sensors

- Sensor element and electronics can be changed
- Flat & compact sensor electronics housing
- Electrical connection is freely rotatable

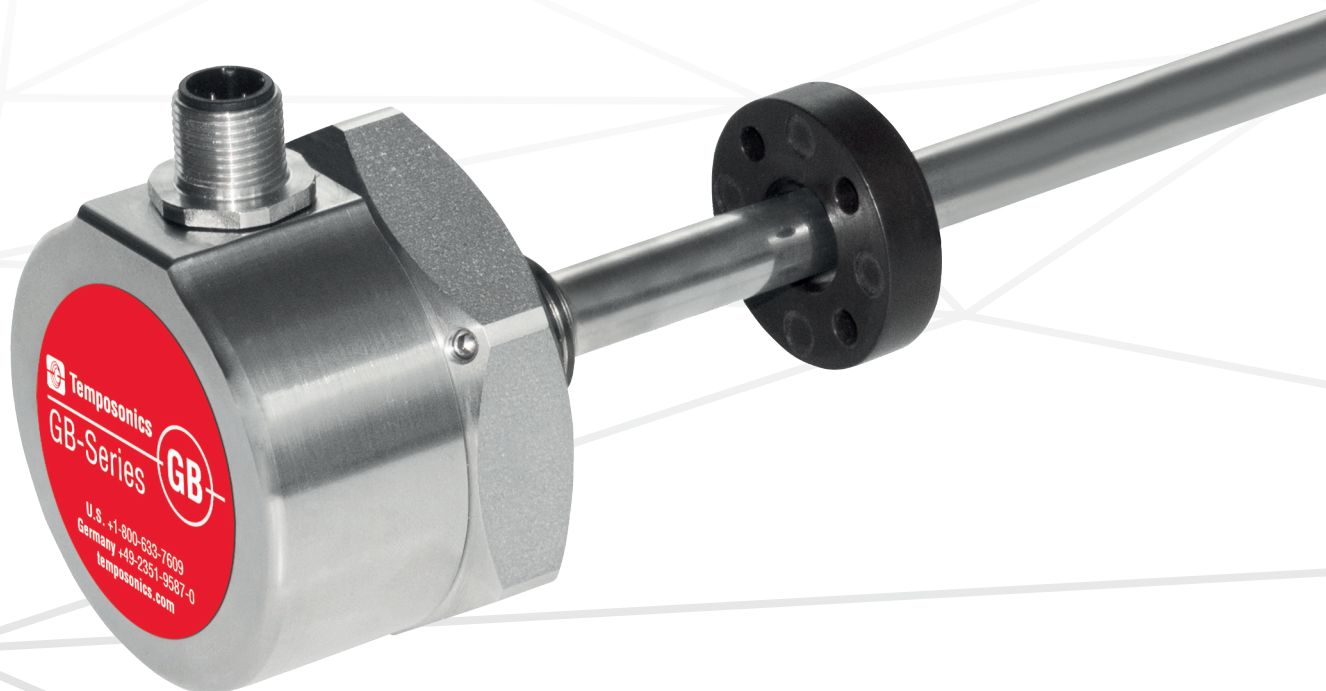

MEASURING TECHNOLOGY

The absolute, linear position sensors provided by Temposonics rely on the company's proprietary magnetostrictive technology, which can determine position with a high level of precision and robustness. Each Temposonics® position sensor consists of a ferromagnetic waveguide, a position magnet, a strain pulse converter and supporting electronics. The magnet, connected to the object in motion in the application, generates a magnetic field at its location on the waveguide. A short current pulse is applied to the waveguide. This creates a momentary radial magnetic field and torsional strain on the waveguide. The momentary interaction of the magnetic fields releases a torsional strain pulse that propagates the length of the waveguide. When the ultrasonic wave reaches the beginning of the waveguide it is converted into an electrical signal. Since the speed of the ultrasonic wave in the waveguide is precisely known, the time required to receive the return signal can be converted into a linear position measurement with both high accuracy and repeatability.

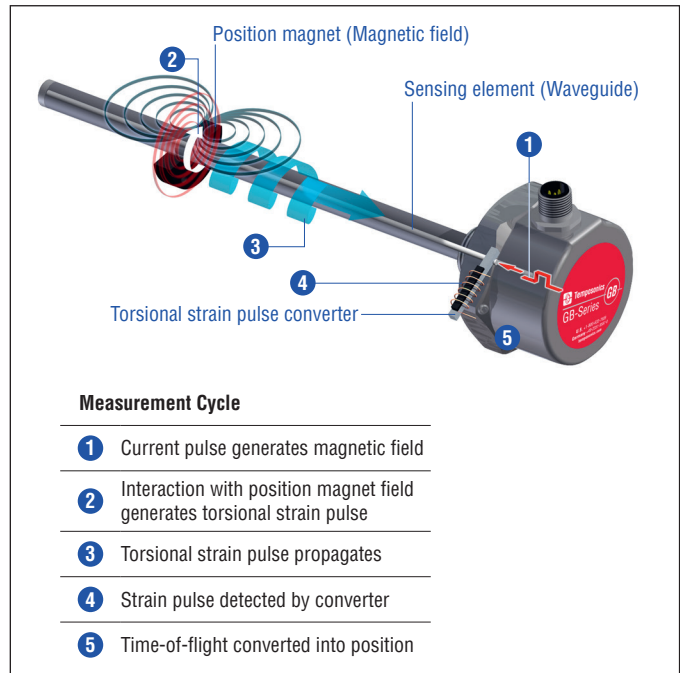

Fig. 1: Time-of-flight based magnetostrictive position sensing principle

GB-M/GB-T SENSOR

Robust, non-contact and wear free, the Temposonics® linear position sensors provide the best durability and accurate position measurement solutions in harsh industrial environments. The high quality of the in-house manufactured waveguide forms the basis for precise measurements. The position magnet is mounted on the moving machine part and travels non-contact over the sensor rod with the built-in waveguide.

The GB-M/GB-T is an extension of the Temposonics® GB-Series. Its compact housing can be easily mounted, even if there is only limited space. Due to the high temperature resistance, no measures for cooling the sensor have to be taken – saving you time and work. Further advantages of the GB-M/GB-T sensor are:

TURN ME.

The sensor electronics housing with its electrical connection can be rotated 360 degrees after mounting to easily achieve the necessary connection orientation.



REPLACE ME.

If needed, the sensor element and electronics can be replaced without interrupting the hydraulic circuit – resulting in lower maintenance costs and reduced downtime.

PROGRAM ME.

The start position and end position of the measurement range are programmable, e.g. via programming kit, allowing users to adjust to meet the application requirements.

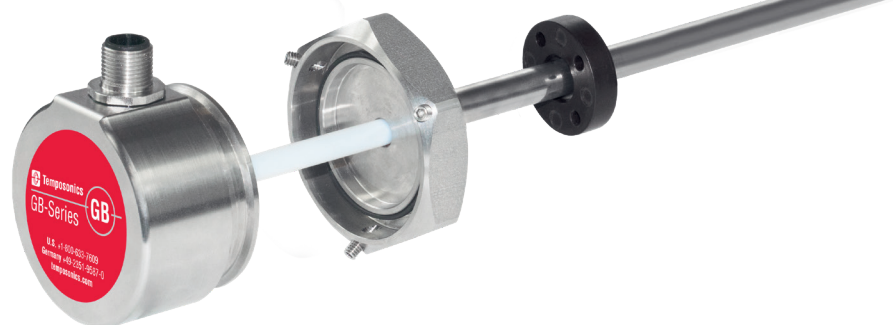
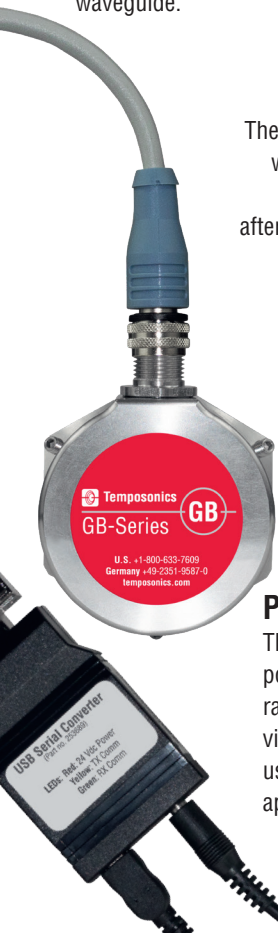

TECHNICAL DATA

Output	
Interface	SSI (Synchronous Serial Interface) – Differential signal in SSI standard
Data format	Binary, gray
Programming	Programming of set points using optional accessories
Measured value	Position
Measurement parameters	
Resolution	Min. resolution 5 µm
Cycle time	Up to 3.7 kHz depending on stroke length
Linearity	≤ ±0.02 % F.S. (minimum ±60 µm) typically
Repeatability	≤ ±0.005 % F.S. (minimum ±20 µm) typically
Operating conditions	
Operating temperature	–40...+90 °C (–40...+194 °F), Options: –40...+100 °C (–40...+212 °F)
Ingress protection	IP67 with proper mating connector IP68 for cable outlet
Shock test	100 g (single shock), IEC standard 60068-2-27
Vibration test	15 g/10...2000 Hz, IEC standard 60068-2-6 (resonance frequencies excluded)
EMC test	Electromagnetic emission according to EN 61000-6-4 Electromagnetic immunity according to EN 61000-6-2 The GB sensors fulfill the requirements of the EMC directives 2014/30/EU, UKSI 2016 No. 1091 and TR CU 020/2011.
Magnet movement velocity	Any
Design/Material	
Sensor electronics housing ¹	Stainless steel 1.4305 (AISI 303)
Sensor rod	Stainless steel 1.4306; 1.4307 (AISI 304L)
RoHS compliance	The used materials are compliant with the requirements of EU Directive 2011/65/EU and EU Regulation 2015/863 as well as UKSI 2022 No. 622 with amendments
Stroke length	25...3250 mm (1...128 in.)
Operating pressure	350 bar (5,076 psi), 700 bar (10,153 psi) peak (at 10 × 1 min)
Mechanical mounting	
Mounting position	Any
Mounting instruction	Please consult the technical drawings on page 4 and the operation manual (document number: 551631)
Electrical connection	
Connection type	M12 male connector (8 pin) A-coded M16 male connector (7 pin) Cable outlet
Operating voltage	+24 VDC (–15/+20 %); the GB sensors must be power supplied via an external Class 2 power source in accordance with the UL approval
Ripple	≤ 0.28 V _{pp}
Current consumption	90 mA typically
Dielectric strength	500 VDC (DC ground to machine ground)
Polarity protection	Up to –30 VDC
Overvoltage protection	Up to 36 VDC

^{1/} For option **H** (–40...+100 °C/–40...+212 °F) an aluminum cover plate is used

TECHNICAL DRAWING

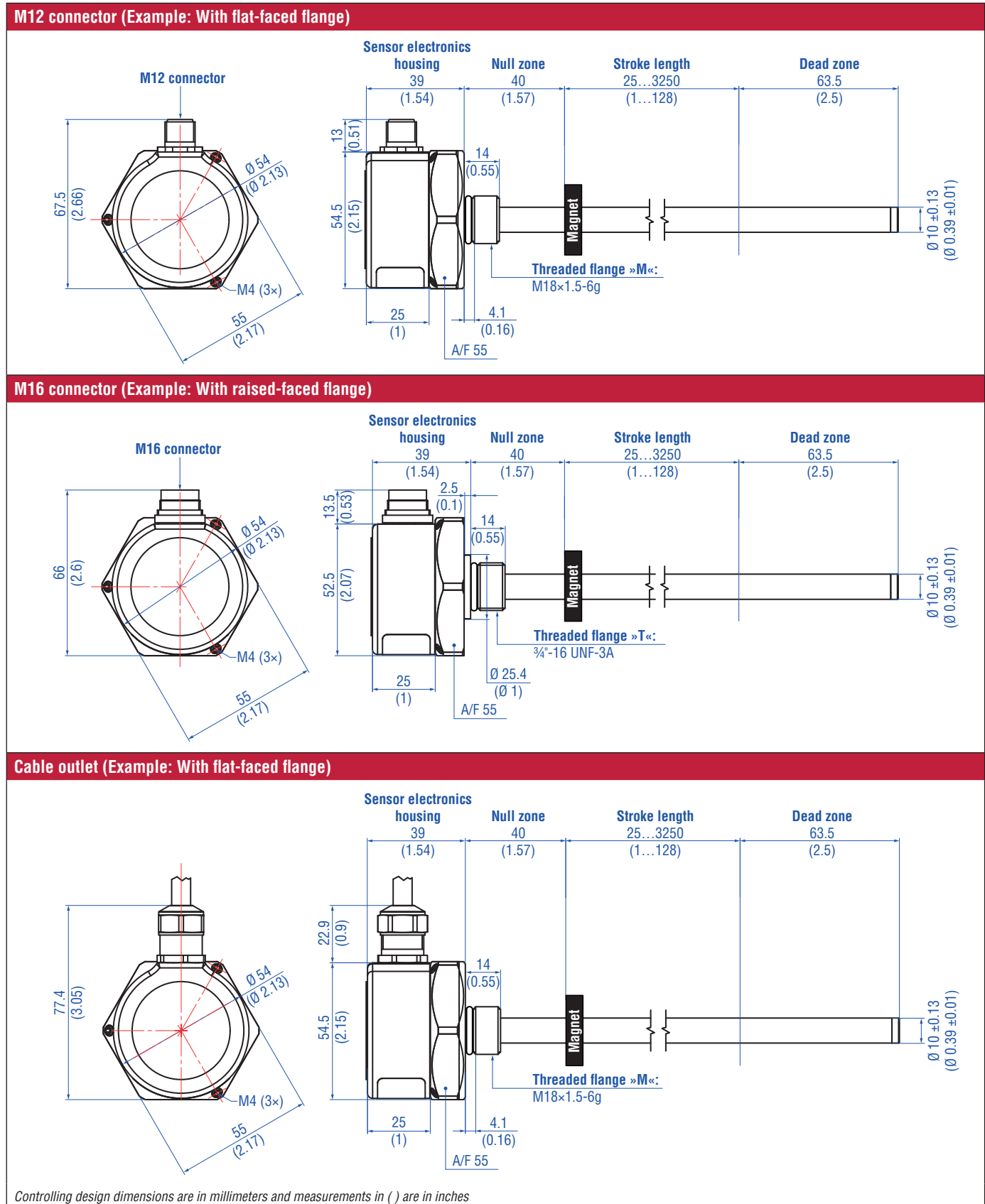

Fig. 2: Temposonics® GB-M/GB-T with ring magnet

CONNECTOR WIRING

D84		
Signal + power supply		
M12 male connector (A-coded)	Pin	Function
 <p>View on sensor</p>	1	Clock (+)
	2	Clock (-)
	3	Data (+)
	4	Data (-)
	5	Not connected
	6	Not connected
	7	+24 VDC (-15/+20 %)
	8	DC Ground (0 V)

Fig. 3: Connector wiring D84 (M12 connector)

D70		
Signal + power supply		
M16 male connector	Color	Function
 <p>View on sensor</p>	1	Data (-)
	2	Data (+)
	3	Clock (+)
	4	Clock (-)
	5	+24 VDC (-15/+20 %)
	6	DC Ground (0 V)
	7	Not connected

Fig. 4: Connector wiring D70 (M16 connector)

GB with cable outlet (HXX/TXX/VXX)		
Signal + power supply		
Cable	Color	Function
	GY	Data (-)
	PK	Data (+)
	YE	Clock (+)
	GN	Clock (-)
	BN	+24 VDC (-15/+20 %)
	WH	DC Ground (0 V)

For cable type TXX, the extra red & blue wires are not used.

Fig. 5: Connector wiring (cable outlet)

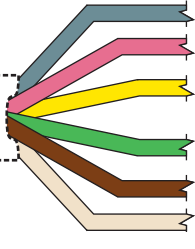
FREQUENTLY ORDERED ACCESSORIES – Additional options available in our [Accessories Catalog](#) 551444

Position magnets

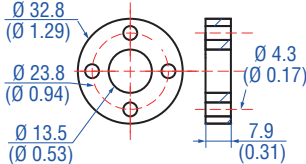
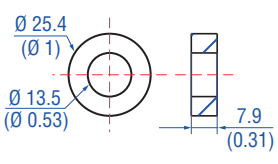
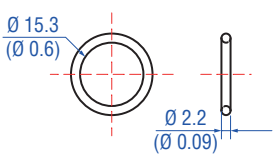
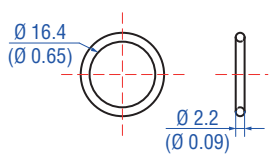

			
<p>Ring magnet OD33 Part no. 201 542-2</p> <p>Material: PA ferrite GF20 Weight: Approx. 14 g Surface pressure: Max. 40 N/mm² Fastening torque for M4 screws: 1 Nm Operating temperature: -40...+120 °C (-40...+248 °F)</p>	<p>Ring magnet OD25.4 Part no. 400 533</p> <p>Material: PA ferrite Weight: Approx. 10 g Surface pressure: Max. 40 N/mm² Operating temperature: -40...+120 °C (-40...+248 °F)</p>	<p>O-ring for threaded flange M18x1.5-6g Part no. 401 133</p> <p>Material: Fluoroelastomer Durometer: 75 ±5 Shore A Operating temperature: -40...+204 °C (-40...+400 °F)</p>	<p>O-ring for threaded flange 3/4"-16 UNF-3A Part no. 560 315</p> <p>Material: Fluoroelastomer Durometer: 75 ±5 Shore A Operating temperature: -40...+204 °C (-40...+400 °F)</p>

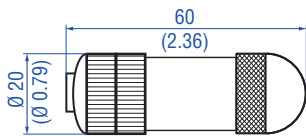
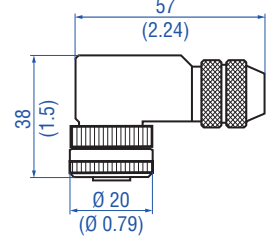
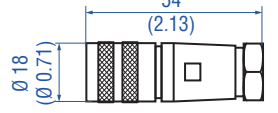
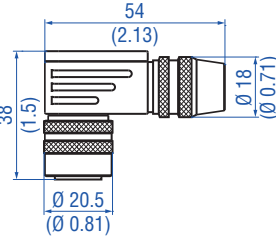
Cable connectors*

			
<p>M12 A-coded female connector (8 pin), straight Part no. 370 694</p> <p>Housing: GD-ZnAL Termination: Screw Contact insert: CuZn Cable Ø: 4...9 mm (0.16...0.35 in.) Wire: 0.75 mm² Operating temperature: -25...+90 °C (-13...+194 °F) Ingress protection: IP67 (correctly fitted) Fastening torque: 0.6 Nm</p>	<p>M12 A-coded female connector (8 pin), angled Part no. 370 699</p> <p>Housing: GD-ZnAL Termination: Screw Contact insert: CuZn Cable Ø: 6...8 mm (0.24...0.31 in.) Wire: 0.5 mm² Operating temperature: -25...+85 °C (-13...+185 °F) Ingress protection: IP67 (correctly fitted) Fastening torque: 0.6 Nm</p>	<p>M16 female connector (7 pin), straight Part no. 370 624</p> <p>Material: Zinc nickel plated Termination: Solder Contact insert: Silver plated Cable clamp: PG9 Cable Ø: 6...8 mm (0.24...0.31 in.) Operating temperature: -40...+100 °C (-40...+212 °F) Ingress protection: IP65/IP67 (correctly fitted) Fastening torque: 0.7 Nm</p>	<p>M16 female connector (7 pin), angled Part no. 560 779</p> <p>Material: Zinc nickel plated Termination: Solder Contact insert: Silver plated Cable Ø: 6...8 mm (0.24...0.31 in.) Wire: 0.75 mm² (20 AWG) Operating temperature: -40...+95 °C (-40...+203 °F) Ingress protection: IP67 (correctly fitted) Fastening torque: 0.5 Nm</p>

*/ Follow the manufacturer's mounting instructions

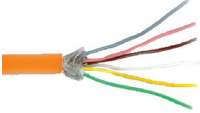
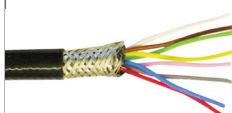
Controlling design dimensions are in millimeters and measurements in () are in inches

Cables			Programming tool
			
PUR cable Part no. 530 052 Material: PUR jacket; orange Features: Twisted pair, shielded, highly flexible, halogen free, suitable for drag chains, mostly oil & flame resistant Cable Ø: 6.4 mm (0.25 in.) Cross section: 3 × 2 × 0.19 mm ² Bending radius: 5 × D (fixed installation) Operating temperature: -20...+80 °C (-4...+176 °F)	FEP cable Part no. 530 112 Material: FEP jacket; black Features: Twisted pair, shielded, flexible, high thermal resistance, mostly oil & acid resistant Cable Ø: 7.6 mm (0.3 in.) Cross section: 4 × 2 × 0.25 mm ² Bending radius: 8 – 10 × D (fixed installation) Operating temperature: -100...+180 °C (-148...+356 °F)	Silicone cable Part no. 530 113 Material: Silicone jacket; red Features: Twisted pair, shielded, highly flexible, halogen free, high thermal resistance Cable Ø: 7.2 mm (0.28 in.) Cross section: 3 × 2 × 0.25 mm ² Bending radius: 5 × D (fixed installation) Operating temperature: -50...+180 °C (-58...+356 °F)	Programming kit Part no. 254 590 Kit includes: 1 × interface converter box 1 × power supply 1 × cable (60 cm) with M12 female connector (8 pin), straight – D-sub female connector (9 pin), straight 1 × cable (60 cm) with M16 female connector (7 pin), straight – D-sub female connector (9 pin), straight 1 × cable (60 cm) with 6 × terminal clamp – D-sub female connector (9 pin), straight 1 × USB cable Software is available at: www.temposonics.com

Color of connectors and cable jacket may change. Color codes for the individual wires and technical properties remain unchanged.

Temposonics® GB-Series with threaded flange SSI

Data Sheet

ORDER CODE

1	2	3	4	5	6	7	8	9	10	11	12	13	14	15	16	17	18	19	20	21
G	B										1	S								C
a	b	c						d	e	f						g	h			

a	Sensor model
G B	Rod

b	Design
B	Base unit for flange »M« and flange »T«
M	Flat-faced flange, M18×1.5-6g
T	Raised-faced flange, ¾"-16 UNF-3A

c	Stroke length
X X X X M	0025...3250 mm
Standard stroke length (mm) Ordering steps	
25... 500 mm	5 mm
500... 750 mm	10 mm
750... 1000 mm	25 mm
1000... 2500 mm	50 mm
2500... 3250 mm	100 mm
X X X X U	001.0...128.0 in.
Standard stroke length (in.) Ordering steps	
1... 20 in.	0.2 in.
20... 30 in.	0.4 in.
30... 40 in.	1.0 in.
40... 100 in.	2.0 in.
100... 128 in.	4.0 in.
Non-standard stroke lengths are available; must be encoded in 5 mm/0.1 in. increments.	

d	Connection type
D 8 4	M12 male connector (8 pin) (A-coded)
D 7 0	M16 male connector (7 pin)
H X X	PUR cable (part no. 530 052) (suitable for max. operating temperature of +80 °C (+176 °F)) H01...H10 (1...10 m/3...33 ft.) See "Frequently ordered accessories" for cable specifications
T X X	FEP cable (part no. 530 112) T01...T10 (1...10 m/3...33 ft.) See "Frequently ordered accessories" for cable specifications
V X X	Silicone cable (part no. 530 113) V01...V10 (1...10 m/3...33 ft.) See "Frequently ordered accessories" for cable specifications
Encode in meters if using metric stroke length. Encode in feet if using US customary stroke length	

e	Operating voltage
1	+24 VDC (-15/+20 %)

f	Output
S (14) (15) (16) (17) (18) (19)	= Synchronous Serial Interface
Data length (box no. 14)	
1	25 bit
2	24 bit
Output format (box no. 15)	
B	Binary
G	Gray
Resolution (box no. 16)	
1	0.005 mm (5 µm)
2	0.01 mm (10 µm)
3	0.05 mm (50 µm)
4	0.1 mm (100 µm)
5	0.02 mm (20 µm)
Filter (box no. 17)	
1	No filter
2	Average filter 2
3	Average filter 4
4	Average filter 8
Performance (box no. 18, 19)	
0 0	Measuring direction forward, asynchronous measurement
0 1	Measuring direction reverse, asynchronous measurement
0 2	Measuring direction forward, synchronous measurement
0 3	Measuring direction reverse, synchronous measurement

g	Operating temperature
H	-40...+100 °C (-40...+212 °F)
S	-40...+90 °C (-40...+194 °F)

h	Programming
C	Via cable

DELIVERY



GB-B:
Sensor

GB-M/GB-T:
Sensor
O-ring

Accessories have to be ordered separately.

Manuals, Software & 3D Models available at:
www.temposonics.com

USA
Temposonics, LLC
Amerika & APAC Region
3001 Sheldon Drive
Cary, N.C. 27513
Telefon: +1 919 677-0100
E-Mail: info.us@temposonics.com

DEUTSCHLAND
Temposonics GmbH & Co. KG
EMEA Region & India
Auf dem Schüffel 9
58513 Lüdenscheid
Telefon: +49 2351 9587-0
E-Mail: info.de@temposonics.com

ITALIEN
Zweigstelle
Telefon: +39 030 988 3819
E-Mail: info.it@temposonics.com

FRANKREICH
Zweigstelle
Telefon: +33 6 14 060 728
E-Mail: info.fr@temposonics.com

UK
Zweigstelle
Telefon: +44 79 21 83 05 86
E-Mail: info.uk@temposonics.com

SKANDINAVIEN
Zweigstelle
Telefon: +46 70 29 91 281
E-Mail: info.sca@temposonics.com

CHINA
Zweigstelle
Telefon: +86 21 3405 7850
E-Mail: info.cn@temposonics.com

JAPAN
Zweigstelle
Telefon: +81 36416 1063
E-Mail: info.jp@temposonics.com

Document Part Number:
551839 Revision D (EN) 03/2026



temposonics.com