

## Data Sheet

### MH-Series SLIM

#### Magnetostrictive Linear Position Sensors

- Embedded and external threaded options
- Stroke lengths up to 600 mm
- For short stroke cylinders with compact pin-to-pin distance
- CANbus and voltage output

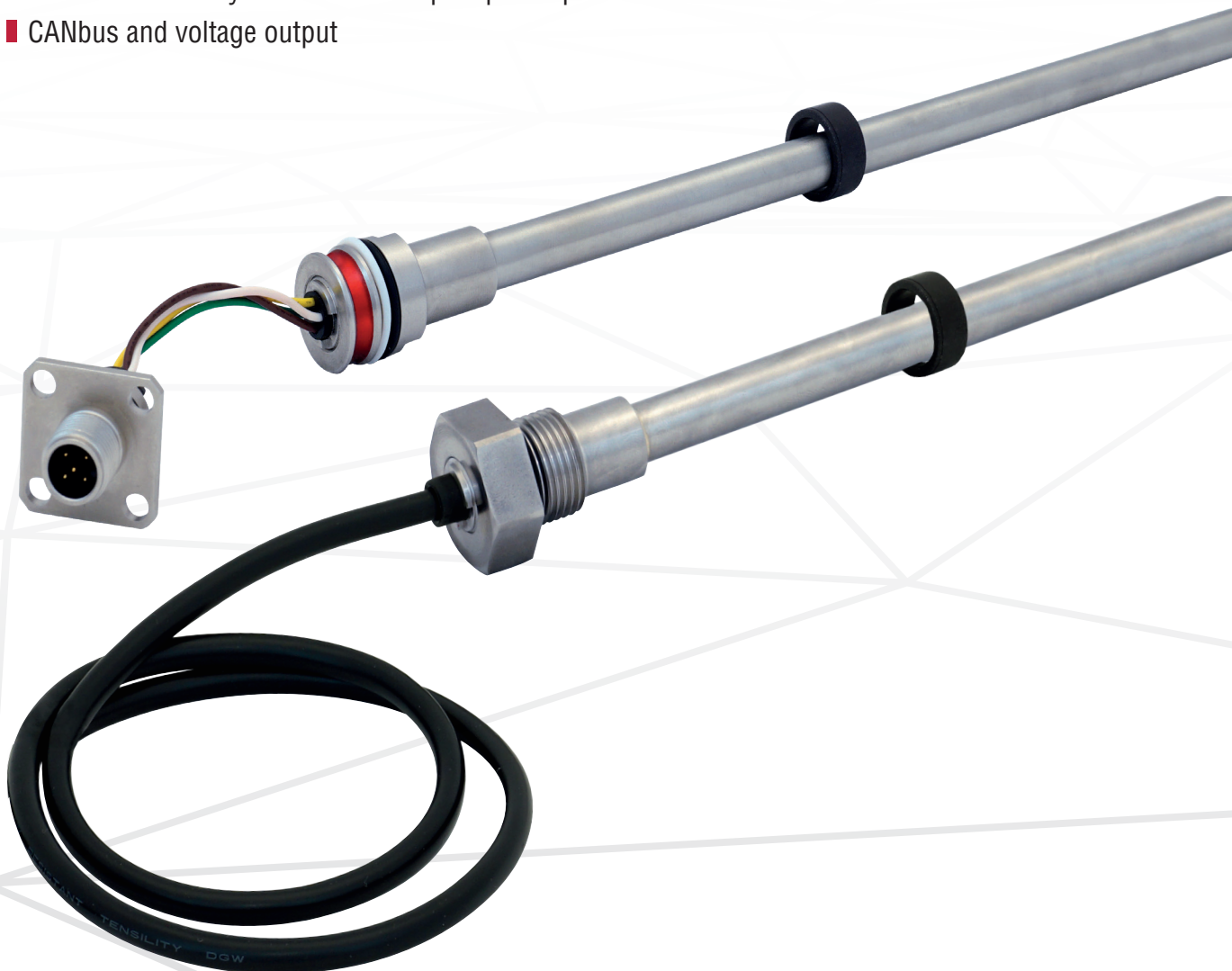

## MEASURING TECHNOLOGY

The absolute, linear position sensors provided by Temposonics rely on the company's proprietary magnetostrictive technology, which can determine position with a high level of precision and robustness. Each Temposonics® position sensor consists of a ferromagnetic waveguide, a position magnet, a strain pulse converter and supporting electronics. The magnet, connected to the object in motion in the application, generates a magnetic field at its location on the waveguide. A short current pulse is applied to the waveguide. This creates a momentary radial magnetic field and torsional strain on the waveguide. The momentary interaction of the magnetic fields releases a torsional strain pulse that propagates the length of the waveguide. When the ultrasonic wave reaches the beginning of the waveguide it is converted into an electrical signal. Since the speed of the ultrasonic wave in the waveguide is precisely known, the time required to receive the return signal can be converted into a linear position measurement with both high accuracy and repeatability.

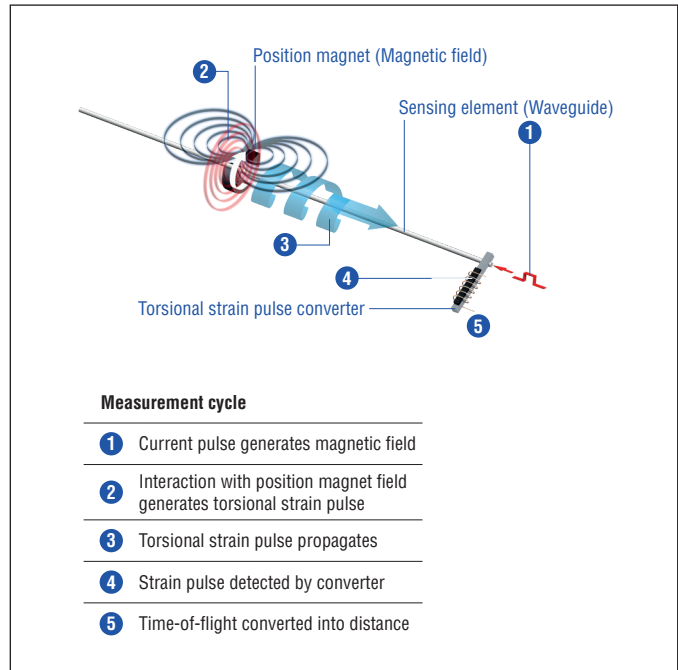

Fig. 1: Time-of-flight based magnetostrictive position sensing principle

## MH-SERIES SLIM

The Temposonics® MH-Series SLIM sensor provides an optimal solution for short-stroke hydraulic cylinders, where a compact pin-to-pin distance is essential. Its streamlined design is well-suited for a diverse array of linear actuation applications in off-highway equipment, including agricultural and farming machinery, compact construction and paving vehicles, forklift trucks, material handling systems, and various other uses.

Leveraging Temposonics® proven magnetostrictive technology, which has demonstrated reliability for decades in the most demanding environments, the MH-Series SLIM delivers exceptional performance in a small package. The SLIM combines non-contact operation with exceptional durability and precision, making it a superior choice for challenging applications where reliability under high shock, vibration, and electromagnetic disturbances is critical.



Fig. 2: Typical applications

## DESIGNED FOR THE MOBILE WORLD

The MH-Series SLIM Sensor is designed for the widest variety of mobile machines and intended for in-cylinder use, including threaded mounting options for in-field servicability.

## TECHNICAL DATA ANALOG

Output	
Voltage	0.25...4.75 VDC / 0.5...4.5 VDC / 4.75...0.25 VDC / 4.5...0.5 VDC
Measured value	Position
Measurement parameters	
Stroke length	100...600 mm
Resolution (position)	0.1 mm
Power up time	250 ms (typical)
Repeatability	± 0.1 mm
Linearity	± 0.75 mm
Internal sample rate	6 ms
Setpoint tolerance	≤ 1 mm
Operating conditions	
Operating temperature electronics	-40...+105 °C
Humidity	90 % relative humidity, no condensation, EN 60068-2-30
Ingress protection – Sensor housing	IP67, EN 60529
Shock	100 g (11 ms) single shock per axis, IEC 60068-2-27 50 g (6 ms) at 1000 shocks per axis, IEC 60068-2-29
Vibration	Operational sine vibration test IEC 60068-2-6 10 g (5...2000 Hz)* Survival random vibration test IEC 60068-2-64 15 g RMS (10...2000 Hz) 12 h per axis*
EMC	Compliant with: ISO 13766-1:2018 Earth-moving and building construction machinery EN ISO 14982:2009 Agricultural and Forestry Machinery ISO 16750-2:2012 Road vehicles
EMI	200 V/m (ISO 11452-2:2004 200...2000 MHz) 200 mA (ISO 11452-4:2011 1...200 MHz)
Operating pressure ratings	
	<b>Pressure (according to DIN EN ISO 19879)**</b>
PN (nominal operating)	350 bar
Pmax (max. overload)	450 bar
Pstatic (proof pressure)	625 bar
Design/Material	
Sensor housing	Stainless steel 1.4305 (AISI 303)
Sensor rod	Stainless steel 1.4306 (AISI 304L)
Sealing	O-ring: HNBR 70, back-up ring: PTFE
Electrical connection	
Operating voltage	12/24 VDC nominal (8...32VDC)
Min load resistance (output VDC)	10 kΩ
Max Inrush current	4.5 A/2 ms (2.5 A/2 ms if supply < 13 V)
Supply voltage ripple	< 1 % <sub>pp</sub>
Power drain	< 1 W
Over voltage protection (GND-VDC)	Up to +200 VDC
Polarity protection (GND-VDC)	Up to -200 VDC
Insulation Resistance	R ≥ 10 MΩ @ 60 sec
Electric strength	500 VDC (DC GND to chassis GND)

\*/ Resonance frequencies excluded

\*\*/ According to calculations under use of the FKM guideline

Cycles	Ø 10 mm sensor rod
Dynamic pressure: > 2 × 10 <sup>6</sup> pressure cycles	350 bar
Static pressure: > 2 × 10 <sup>4</sup> pressure cycles	450 bar
Proof pressure: Maximum 5 minutes testing time for cylinder pressure test	625 bar

## TECHNICAL DATA CANbus

Output	
Bus-protocol	SAE J1939, CANopen protocol according to CiA DS-301 V4.1, device profile DS-406 V3.1
Measured value	Position
Measurement parameters	
Stroke length	100...600 mm
Resolution (position)	0.1 mm
Boot up Time	400 ms (typical)
Repeatability	± 0.1 mm
Cycle Time	Programmable (20 ms default)
Linearity	± 0.75 mm
Internal sample rate	10 ms
Setpoint tolerance	≤1 mm
Operating conditions	
Operating temperature electronics	-40...+105 °C
Humidity	90 % relative humidity, no condensation, EN 60068-2-30
Ingress protection – Sensor housing	IP67, EN 60529
Shock	100 g (6 ms) single shock per axis, IEC 60068-2-27 50 g (11 ms) at 1000 shocks per axis, IEC 60068-2-29
Vibration	Operational sine vibration test IEC 60068-2-6 10 g (5...2000 Hz)* Survival random vibration test IEC 60068-2-64 15 g RMS (10...2000 Hz) 12 h per axis*
EMC	Compliant with: ISO 13766-1:2018 Earth-moving and building construction machinery EN ISO 14982:2009 Agricultural and Forestry Machinery ISO 16750-2:2012 Road vehicles
EMI	200 V/m (ISO 11452-2:2004 200...2000 MHz) 200 mA (ISO 11452-4:2011 1...200 MHz)
Operating pressure ratings	
	Pressure (according to DIN EN ISO 19879)**
PN (nominal operating)	350 bar
Pmax (max. overload)	450 bar
Pstatic (proof pressure)	625 bar
Design/Material	
Sensor electronics housing	Stainless steel 1.4305 (AISI 303)
Sensor rod	Stainless steel 1.4306 (AISI 304L)
Sealing	O-ring: HNBR 70, back-up ring: PTFE
Electrical connection	
Operating voltage	12/24 VDC nominal (8...32 VDC)
Max Inrush current	1.5 A/2 ms (1.0 A/2 ms if supply > 13 V)
Supply voltage ripple	< 1 % <sub>pp</sub>
Power drain	< 1.5 W
Over voltage protection (GND-VDC)	Up to +200 VDC
Polarity protection (GND-VDC)	Up to -200 VDC
Insulation Resistance	R ≥ 10 MΩ @ 60 sec
Electric strength	500 VDC (DC GND to chassis GND)

\* / Resonance frequencies excluded

\*\* / According to calculations under use of the FKM guideline

Cycles	Ø 10 mm sensor rod
Dynamic pressure: > 2 × 10 <sup>6</sup> pressure cycles	350 bar
Static pressure: > 2 × 10 <sup>4</sup> pressure cycles	450 bar
Proof pressure: Maximum 5 minutes testing time for cylinder pressure test	625 bar

## TECHNICAL DRAWING

### SM-D – Pressure fit flange

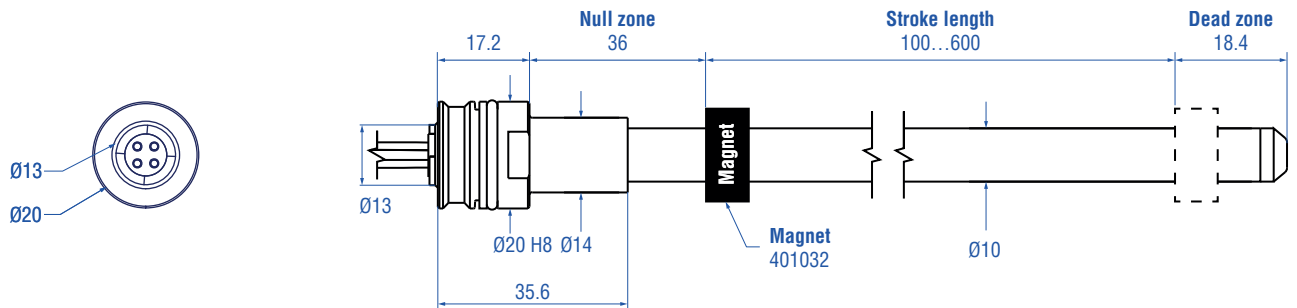

### SM-B/E – Threaded flange

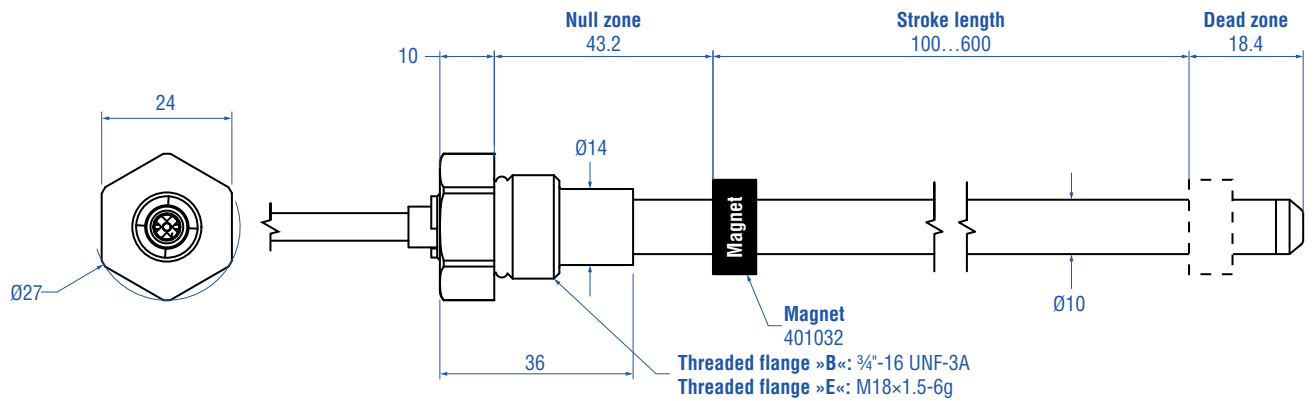





Controlling design dimensions are in millimeters

Fig. 3: Temposonics® MH-Series SLIM Sensor

### NOTICE

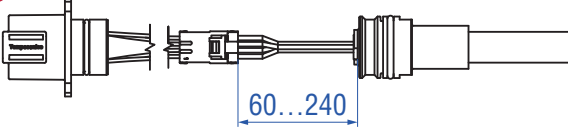
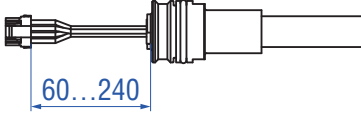
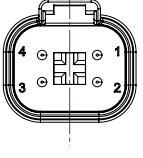
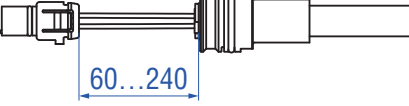
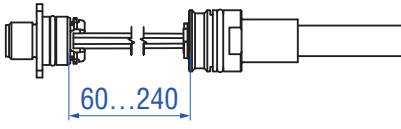
Installation Manual for MH-Series SLIM Sensors (document part no. [552184](#))

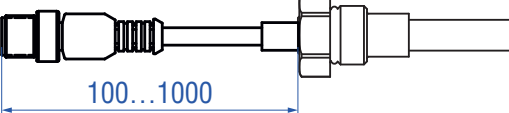
## CONNECTOR WIRING ANALOG

(1) DT connector system (A...E/A...G/A...H) & (2) Interconnect without DT connector system (W...E/W...G/W...H)							
<b>1</b> 	<ul style="list-style-type: none"> <li>• Single lead wires 0.22 mm<sup>2</sup></li> <li>• Attached DT compatible connector</li> <li>• Sealing IP69K (with or without mating connector)</li> <li>• Wiring sequence controlled at sensor</li> </ul>						
<b>2</b> 	 View on connector						
Connector wiring		E		G		H	
Pin	Wire	Function	Wire	Function	Wire	Function	Function
1	YE	n.c.	BN	VDC	BN	VDC	
2	BN	VDC	YE	n.c.	GN	SIG	
3	WH	GND	WH	GND	WH	GND	
4	GN	SIG	GN	SIG	YE	n.c.	
(1) M12 connector system without flange (K...E/K...G/K...H) & (2) with flange (N...E/N...G/N...H)							
<b>1</b> 	<ul style="list-style-type: none"> <li>• Single lead wires 0.22 mm<sup>2</sup></li> <li>• Attached A-coded M12 connector</li> <li>• Toolless Assembly</li> <li>• Sealing IP67, up to IP69K with mating connector</li> </ul>						
<b>2</b> 	 View on connector						
Connector wiring		E		G		H	
Pin	Wire	Function	Wire	Function	Wire	Function	Function
1	YE	n.c.	BN	VDC	BN	VDC	
2	BN	VDC	YE	n.c.	GN	SIG	
3	WH	GND	WH	GND	WH	GND	
4	GN	SIG	GN	SIG	YE	n.c.	
Cable with M12 connector (Q...E/Q...G/Q...H)							
	<ul style="list-style-type: none"> <li>• Cable output Ø 5 mm</li> <li>• Attached A-coded M12 connector</li> <li>• Sealing IP67, up to IP69K with mating connector</li> </ul>						
 View on connector							
Connector wiring		E		G		H	
Pin	Wire	Function	Wire	Function	Wire	Function	Function
1	YE	n.c.	BN	VDC	BN	VDC	
2	BN	VDC	YE	n.c.	GN	SIG	
3	WH	GND	WH	GND	WH	GND	
4	GN	SIG	GN	SIG	YE	n.c.	

**Cable outlet with DT04-4P style connector (F...E/F...G/F...H)**

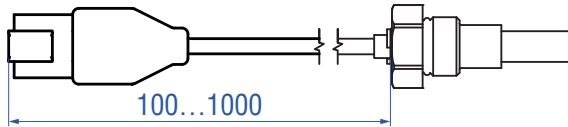

- Cable output Ø 5 mm
- Attached DT04-4P style connector
- Toolless Assembly
- Sealing IP67, up to IP69K with mating connector

Connector wiring		E		G		H	
Pin	Wire	Function	Wire	Function	Wire	Function	
1	YE	n.c.	BN	VDC	BN	VDC	
2	BN	VDC	YE	n.c.	GN	SIG	
3	WH	GND	WH	GND	WH	GND	
4	GN	SIG	GN	SIG	YE	n.c.	

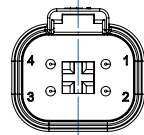

View on connector

**Single wires (S...A)**

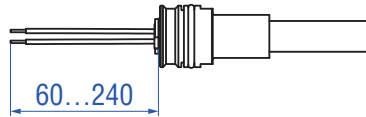

- Single lead wires, 3 × 0.5 mm<sup>2</sup>
- Insulated PVC

Connector wiring		Color	Function
		BN	VDC
		WH	GND
		GN	SIG

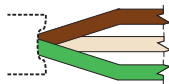

**Cable outlet (T...A)**

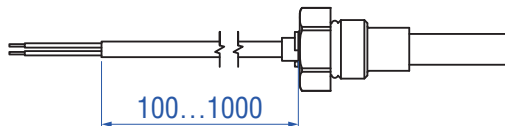



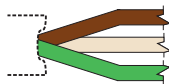

- Cable output Ø 5 mm
- Toolless Assembly

Connector wiring		Color	Function
		BN	VDC
		WH	GND
		GN	SIG

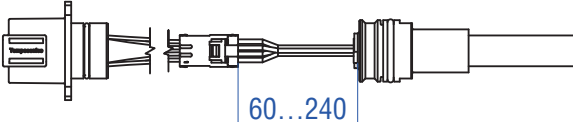
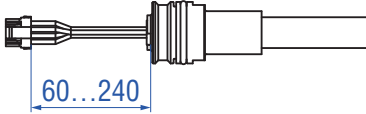
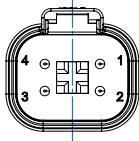
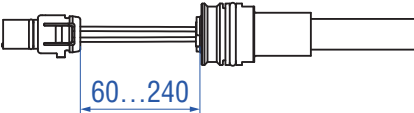
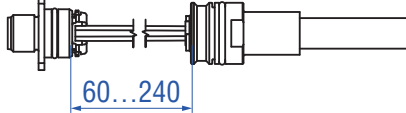

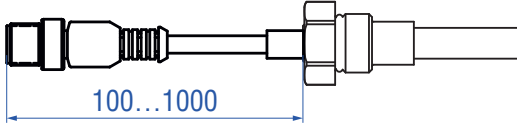
## CONNECTOR WIRING CANbus

(1) DT connector system (A...S) & (2) Interconnect without DT connector system (W...S)																			
<p><b>1</b></p> 	<ul style="list-style-type: none"> <li>• Single lead wires 0.22 mm<sup>2</sup></li> <li>• 4 pin DT style connector</li> <li>• Toolless Assembly</li> <li>• Sealing IP67, up to IP69K with mating connector</li> </ul>																		
<p><b>2</b></p> 	<div style="display: flex; align-items: center;">  <table border="1" style="margin-left: 20px;"> <thead> <tr> <th>Pin</th> <th>Function</th> </tr> </thead> <tbody> <tr> <td>1</td> <td>VDC</td> </tr> <tr> <td>2</td> <td>CAN_L</td> </tr> <tr> <td>3</td> <td>GND</td> </tr> <tr> <td>4</td> <td>CAN_H</td> </tr> </tbody> </table> </div> <p style="text-align: center; font-size: small;">View on connector</p>	Pin	Function	1	VDC	2	CAN_L	3	GND	4	CAN_H								
Pin	Function																		
1	VDC																		
2	CAN_L																		
3	GND																		
4	CAN_H																		
(1) M12 connector system without flange (K ...F) & (2) with flange (N...F)																			
<p><b>1</b></p> 	<ul style="list-style-type: none"> <li>• Single lead wires 0.22 mm<sup>2</sup></li> <li>• Attached A-coded M12 connector</li> <li>• Toolless Assembly</li> <li>• Sealing IP67, up to IP69K with mating connector</li> </ul>																		
<p><b>2</b></p> 	<div style="display: flex; align-items: center;">  <table border="1" style="margin-left: 20px;"> <thead> <tr> <th>Pin</th> <th>Wire</th> <th>Function</th> </tr> </thead> <tbody> <tr> <td>1</td> <td>–</td> <td>–</td> </tr> <tr> <td>2</td> <td>BN</td> <td>VDC</td> </tr> <tr> <td>3</td> <td>WH</td> <td>GND</td> </tr> <tr> <td>4</td> <td>YE</td> <td>CAN_H</td> </tr> <tr> <td>5</td> <td>GN</td> <td>CAN_L</td> </tr> </tbody> </table> </div> <p style="text-align: center; font-size: small;">View on connector</p>	Pin	Wire	Function	1	–	–	2	BN	VDC	3	WH	GND	4	YE	CAN_H	5	GN	CAN_L
Pin	Wire	Function																	
1	–	–																	
2	BN	VDC																	
3	WH	GND																	
4	YE	CAN_H																	
5	GN	CAN_L																	
Cable with M12 connector outlet (Q...F)																			
	<ul style="list-style-type: none"> <li>• Cable output Ø 5 mm</li> <li>• Attached A-coded M12 connector</li> <li>• Sealing IP67, up to IP69K with mating connector</li> </ul>																		
<p style="font-size: small;">View on connector</p> 	<table border="1"> <thead> <tr> <th>Pin</th> <th>Wire</th> <th>Function</th> </tr> </thead> <tbody> <tr> <td>1</td> <td>–</td> <td>–</td> </tr> <tr> <td>2</td> <td>BN</td> <td>VDC</td> </tr> <tr> <td>3</td> <td>WH</td> <td>GND</td> </tr> <tr> <td>4</td> <td>YE</td> <td>CAN_H</td> </tr> <tr> <td>5</td> <td>GN</td> <td>CAN_L</td> </tr> </tbody> </table>	Pin	Wire	Function	1	–	–	2	BN	VDC	3	WH	GND	4	YE	CAN_H	5	GN	CAN_L
Pin	Wire	Function																	
1	–	–																	
2	BN	VDC																	
3	WH	GND																	
4	YE	CAN_H																	
5	GN	CAN_L																	

**Cable outlet with DT04-4P style connector (F...S)**

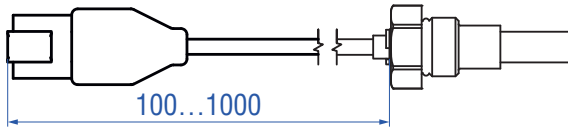

- Cable output Ø 5 mm
- Attached DT04-4P style connector
- Toolless Assembly
- Sealing IP67, up to IP69K with mating connector

**Connector wiring**

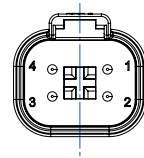

View on connector

Pin	Function
1	VDC
2	CAN_L
3	GND
4	CAN_H

**Single wires (S...A)**

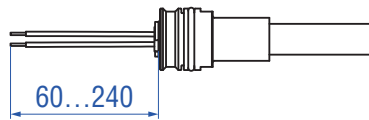

- Single lead wires 0.5 mm<sup>2</sup>
- Insulation PVC

**Connector wiring**

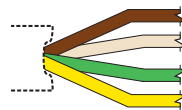

Wire	Function
BN	VDC
WH	GND
GN	CAN_L
YE	CAN_H

**Cable outlet (T...A)**

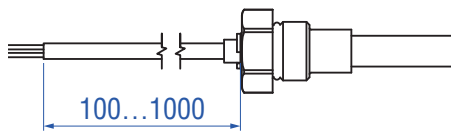

- Cable output Ø 5 mm
- Toolless Assembly

**Connector wiring**

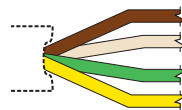

Color	Function
BN	VDC
WH	GND
GN	CAN_L
YE	CAN_H

## ORDER CODE ANALOG

1	2	3	4	5	6	7	8	9	10	11	12	13	14	15	16		
S	M						M					3					
a		b	c					d				e			f		

<b>a</b>	<b>Sensor model</b>	
S	M	MH-Series SLIM

<b>b</b>	<b>Design</b>
D	Pressure fit flange (20 mm)
B	Threaded flange ¾"-16 UNF-3A
E	Threaded flange M18×1.5-6g

<b>c</b>	<b>Stroke length</b>				
X	X	X	X	M	0100...0600 mm (in 5 mm steps)

<b>d</b>	<b>Electrical wiring</b>
for pressure fit flange »D«	

### DT connector system (VDC – GND – SIG)

A			E	60...240 mm wire length (in 20 mm steps) Example wire length A06E = 60 mm Connector wiring E: 2-3-4
A			G	60...240 mm wire length (in 20 mm steps) Example wire length A06G = 60 mm Connector wiring G: 1-3-4
A			H	60...240 mm wire length (in 20 mm steps) Examples wire length A06H = 60 mm Connector wiring H: 1-3-2

### Interconnect without DT connector

W			E	60...240 mm wire length (in 20 mm steps) Example wire length W06E = 60 mm Connector wiring E: 2-3-4
W			G	60...240 mm wire length (in 20 mm steps) Example wire length W06G = 60 mm Connector wiring G: 1-3-4
W			H	60...240 mm wire length (in 20 mm steps) Example wire length W06H = 60 mm Connector wiring H: 1-3-2

### M12 connector system without flange (VDC – GND – SIG)

K			E	60...240 mm wire length (in 20 mm steps) Examples wire length K06E = 60 mm Connector wiring E: 2-3-4
K			G	60...240 mm wire length (in 20 mm steps) Example wire length K06G = 60 mm Connector wiring G: 1-3-4
K			H	60...240 mm wire length (in 20 mm steps) Example wire length K06H = 60 mm Connector wiring H: 1-3-2

<b>d</b>	<b>Electrical wiring</b>
----------	--------------------------

### M12 connector system (VDC – GND – SIG) with flange

N			E	60...240 mm wire length (in 20 mm steps) Example wire length N06E = 60 mm Connector wiring E: 2-3-4
N			G	60...240 mm wire length (in 20 mm steps) Example wire length N06G = 60 mm Connector wiring G: 1-3-4
N			H	60...240 mm wire length (in 20 mm steps) Example wire length N06H = 60 mm Connector wiring H: 1-3-2

### Single wires

S			A	60...240 mm wire length (in 20 mm steps) Example wire length N20A = 200 mm
---	--	--	---	---

### for threaded flange »B«/»E«

### Cable outlet with DT04-4P

F			E	100...1000 mm (in 100 mm steps) Example wire length F06E = 600 mm Connector wiring E: 2-3-4
F			G	100...1000 mm (in 100 mm steps) Example wire length F06G = 600 mm Connector wiring G: 1-3-4
F			H	100...1000 mm (in 100 mm steps) Example wire length F06H = 600 mm Connector wiring H: 1-3-2

### Cable with M12 termination

Q			E	100...1000 mm (in 100 mm steps) Example wire length Q06E = 600 mm Connector wiring E: 2-3-4
Q			G	100...1000 mm (in 100 mm steps) Example wire length Q06G = 600 mm Connector wiring G: 1-3-4
Q			H	100...1000 mm (in 100 mm steps) Example wire length Q06H = 600 mm Connector wiring H: 1-3-2

### Cable outlet

T			A	100...1000 mm cable length (in 100 mm steps) Example wire length T10A = 1000 mm
---	--	--	---	--

Order code continued on next page

e		Operating voltage
3		12/24 VDC nominal (8...32 VDC)

f			Output
V	1	1	0.25...4.75 VDC
V	1	2	0.5...4.5 VDC
V	1	3	4.75... 0.25 VDC
V	1	4	4.5... 0.5 VDC

## DELIVERY



- Position sensor
  - O-ring
  - Backup-ring (pressure fit flanges only)
  - M12 connector system with M12 flange (when option selected)
  - DT connector system with connector assembly and retainer (when option selected)
- Accessories (e.g. position magnets) have to be ordered separately

Manuals, Software & 3D models available at:  
[www.temposonics.com](http://www.temposonics.com)

## ORDER CODE CANbus

1	2	3	4	5	6	7	8	9	10	11	12	13	14	15	16	17	18	19	20
S	M						M					3							
a		b	c					d				e	f			g	h		i

<b>a</b>	<b>Sensor model</b>
S M	MH-Series SLIM

<b>b</b>	<b>Design</b>
D	Pressure fit flange (20 mm)
B	Threaded flange ¾"-16 UNF-3A
E	Threaded flange M18×1.5-6g

<b>c</b>	<b>Stroke length</b>
X X X X M	0100...0600 mm (in 5 mm steps)

<b>d</b>	<b>Electrical wiring</b>
<b>for pressure fit flange</b>	
<b>DT connector system (VDC – GND – HI – LO)</b>	
A	60...240 mm wire length (in 20 mm steps) <i>Example wire length A06S = 60 mm</i> Connector wiring S: 1-3-4-2
<b>Interconnect without DT connector</b>	
W	60...240 mm wire length (in 20 mm steps) <i>Example wire length W06S = 60 mm</i> Connector wiring S: 1-3-4-2
<b>M12 connector without flange (VDC – GND – HI – LO)</b>	
K	60...240 mm wire length (in 20 mm steps) <i>Example wire length K06F = 60 mm</i> Connector wiring: F: 2-3-4-5
<b>M12 connector with flange (VDC – GND – HI – LO)</b>	
N	60...240 mm wire length (in 20 mm steps) <i>Example wire length N06F = 60 mm</i> Connector wiring: F: 2-3-4-5
<b>Single wires</b>	
S	60...240 mm wire length (in 20 mm steps) <i>Example wire length N20A = 200 mm</i>
<b>for threaded flanges</b>	
<b>Cable outlet with DT04-4P</b>	
F	100...1000 mm (in 100 mm steps) <i>Example wire length F06S = 600 mm</i> Connector wiring S: 1-3-4-2
<b>Cable outlet with M12 connector</b>	
Q	100...1000 mm (in 100 mm steps) <i>Example wire length Q06F = 600 mm</i> Connector wiring: F: 2-3-4-5
<b>Cable outlet</b>	
T	100...1000 mm cable length (in 100 mm steps) <i>Example wire length T10A = 1000 mm</i>

<b>e</b>	<b>Operating voltage</b>
3	12/24 VDC nominal (8...32 VDC)

<b>f</b>	<b>Output</b>
C 0 1	CANopen
J 0 1	SAE J1939

<b>g</b>	<b>Baud rate</b>
<b>CANopen (C01)</b>	
0	1000 kbit/s
1	800 kbit/s
2	500 kbit/s
3	250 kbit/s (default)
4	125 kbit/s
6	50 kbit/s
7	20 kbit/s
8	10 kbit/s
<b>SAE J1939 (J01)</b>	
2	500 kbit/s
3	250 kbit/s (default)

<b>h</b>	<b>Node ID (CANopen) / Source address (SAE J1939)</b>
<b>CANopen (C01)</b>	
	Hex 01...7F (default: 7F)
<b>SAE J1939 (J01)</b>	
	Hex 01...FD (default: FD)

<b>i</b>	<b>Cycle time</b>
C	10 msec
D	20 msec (default CANopen & J1939)
F	30 msec
G	40 msec
H	50 msec

Order code continued on next page

## DELIVERY

---



- Position sensor
  - O-ring
  - Backup-ring (pressure fit flanges only)
  - M12 connector system with M12 flange (when option selected)
  - DT connector system with connector assembly and retainer (when option selected)
- Accessories (e.g. position magnets) have to be ordered separately

**Manuals, Software & 3D models available at:  
[www.temposonics.com](http://www.temposonics.com)**

## FREQUENTLY ORDERED ACCESSORIES

### Position magnets

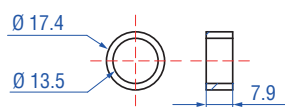

**Ring magnet OD17.4**  
Part no. 401 032

Material: PA neobond  
Weight: Approx. 5 g  
Surface pressure: Max. 20 N/mm<sup>2</sup>  
Operating temperature:  
-40...+105 °C (-40...+221 °F)

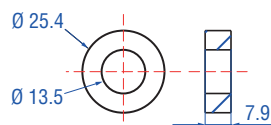

**Ring magnet OD25.4**  
Part no. 400 533

Material: PA ferrite  
Weight: Approx. 10 g  
Surface pressure: Max. 40 N/mm<sup>2</sup>  
Operating temperature:  
-40...+120 °C (-40...+248 °F)

### Connector accessories

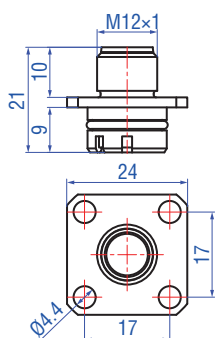

**M12 flange**  
Part no. 253 769

Material: Brass, nickel-plated  
Weight: Approx. 5 g  
Operating temperature:  
-40...+105 °C (-40...+221 °F)

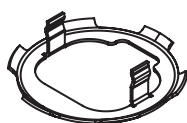

**DT connector system retainer**  
Part no. 520 101

Material: 1.4310  
Weight: Ca. 1.7 g  
Operating temperature:  
-40...+105 °C (-40...+221 °F)

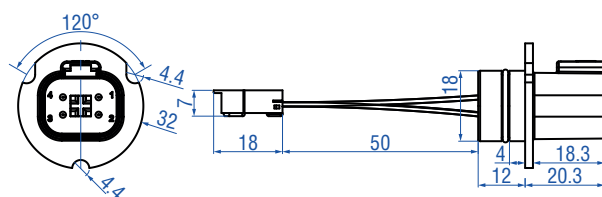

**DT connector assembly**  
Part no. 255 098

Material: PA66  
Weight: Approx. 6 g  
Operating temperature:  
-40...+105 °C (-40...+221 °F)

**Cables**



**Cable with M12 A-coded female connector (5 pin), straight – pigtail  
Part no. 370 673**

Material: PUR jacket; black  
Feature: Shielded  
Cable length: 5 m (16.4 ft)  
Ingress protection: IP67 (correctly fitted)  
Operating temperature:  
-25...+80 °C (-13...+176 °F)

Wiring				M12 A-coded female connector (5 pin)
Wires	Color		Pin	
	BN	↔	1	
	WH	↔	2	
	BU	↔	3	
	BK	↔	4	
	GY	↔	5	



**Cable with M12 A-coded female connector (5 pin), angled – pigtail  
Part no. 370 675**

Material: PUR jacket; black  
Feature: Shielded  
Cable length: 5 m (16.4 ft)  
Ingress protection: IP67 (correctly fitted)  
Operating temperature:  
-25...+80 °C (-13...+176 °F)

Wiring				M12 A-coded female connector (5 pin)
Wires	Color		Pin	
	BN	↔	1	
	WH	↔	2	
	BU	↔	3	
	BK	↔	4	
	GY	↔	5	

**USA**  
**Temposonics, LLC**  
Amerika & APAC Region  
3001 Sheldon Drive  
Cary, N.C. 27513  
Telefon: +1 919 677-0100  
E-Mail: info.us@temposonics.com

---

**DEUTSCHLAND**  
**Temposonics**  
**GmbH & Co. KG**  
EMEA Region & India  
Auf dem Schüffel 9  
58513 Lüdenscheid  
Telefon: +49 2351 9587-0  
E-Mail: info.de@temposonics.com

---

**ITALIEN**  
Zweigstelle  
Telefon: +39 030 988 3819  
E-Mail: info.it@temposonics.com

---

**FRANKREICH**  
Zweigstelle  
Telefon: +33 6 14 060 728  
E-Mail: info.fr@temposonics.com

---

**UK**  
Zweigstelle  
Telefon: +44 79 21 83 05 86  
E-Mail: info.uk@temposonics.com

---

**SKANDINAVIEN**  
Zweigstelle  
Telefon: +46 70 29 91 281  
E-Mail: info.sca@temposonics.com

---

**CHINA**  
Zweigstelle  
Telefon: +86 21 3405 7850  
E-Mail: info.cn@temposonics.com

---

**JAPAN**  
Zweigstelle  
Telefon: +81 3 6416 1063  
E-Mail: info.jp@temposonics.com

**Document Part Number:**  
552179 Revision D (EN) 03/2026



---

**temposonics.com**