

# Temposonics®

Magnetostrictive Linear Position Sensors

## EP2 Start / Stop Data Sheet

- Optimal price- / performance ratio
- Position measurement with more than one magnet
- Smooth & compact

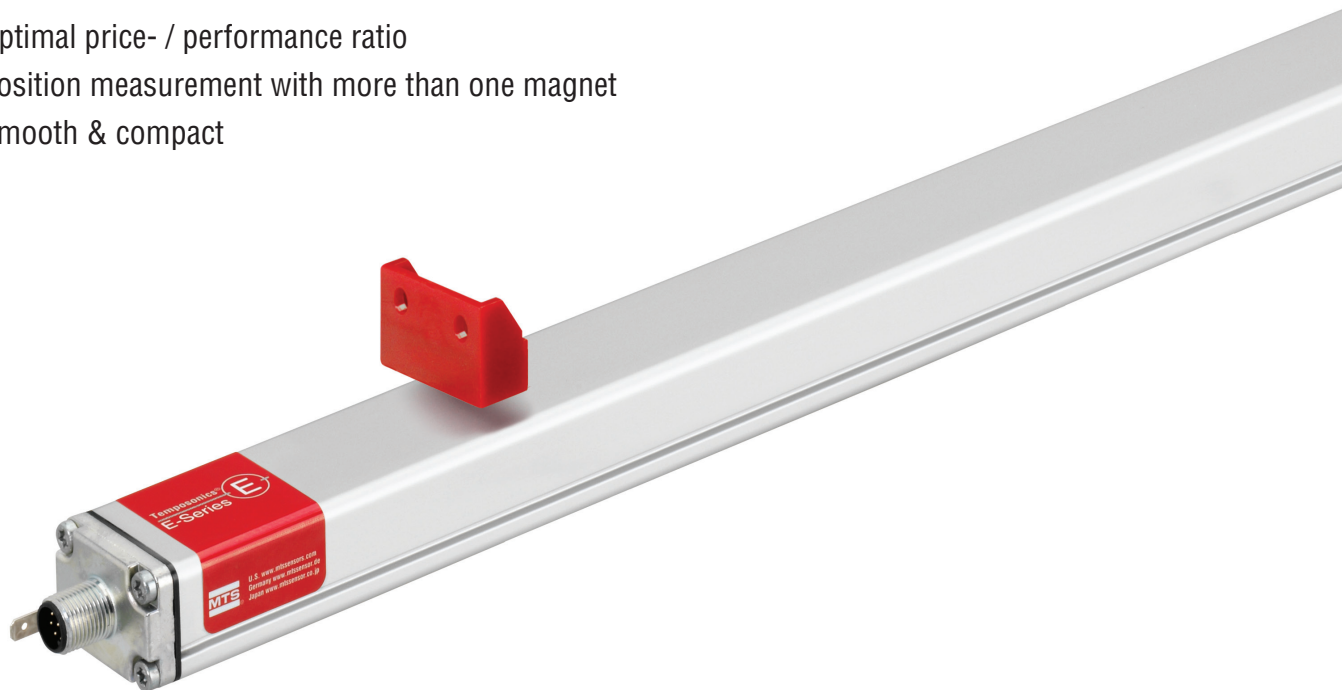

## MEASURING TECHNOLOGY

The absolute, linear position sensors provided by MTS Sensors rely on the company's proprietary Temposonics® magnetostrictive technology, which can determine position with a high level of precision and robustness. Each Temposonics® position sensor consists of a ferromagnetic waveguide, a position magnet, a strain pulse converter and supporting electronics. The magnet, connected to the object in motion in the application, generates a magnetic field at its location on the waveguide. A short current pulse is applied to the waveguide. This creates a momentary radial magnetic field and torsional strain on the waveguide. The momentary interaction of the magnetic fields releases a torsional strain pulse that propagates the length of the waveguide. When the ultrasonic wave reaches the end of the waveguide it is converted into an electrical signal. Since the speed of the ultrasonic wave in the waveguide is precisely known, the time required to receive the return signal can be converted into a linear position measurement with both high accuracy and repeatability.

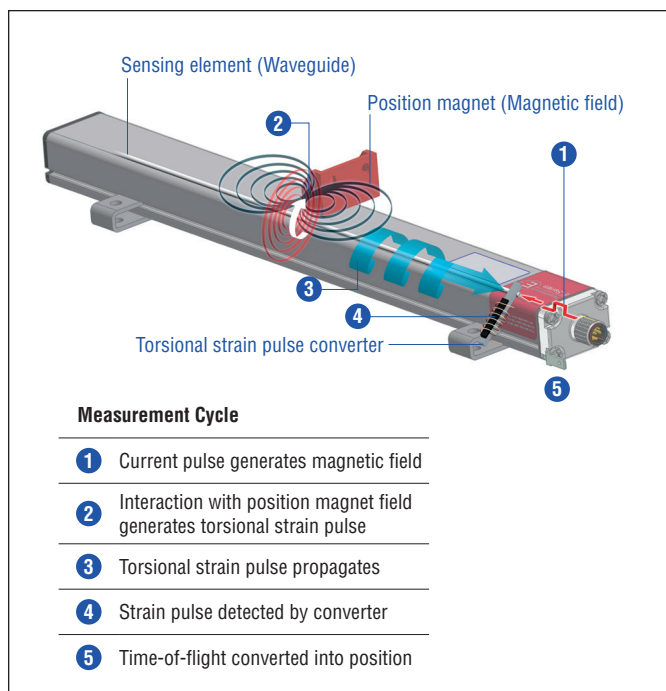

Fig. 1: Time-of-flight based magnetostrictive position sensing principle

## EP2 SENSOR

Robust, non-contact and wear free, the Temposonics® linear position sensor provide high durability and precise position measurement feedback in harsh industrial environments. Measurement accuracy is tightly controlled by the quality of the waveguide manufactured exclusively by MTS Sensors.

The compact and smooth aluminum profile offers flexible mounting options and easy installation. Moreover, the position magnet can travel along the entire flat housing profile. The EP2 has an attractive price- / performance ratio and is ideal for industrial applications including plastics molding and processing, factory automation and packaging.



Fig. 2: Plastic granulate for injection molding or extrusion

## TECHNICAL DATA

Output	
Start / Stop	RS-422 differential signal Serial parameter upload available for: stroke length, offset, gradient, status, serial number and manufacturer number.
Measured variable	Position, Option: Multi-position measurement with a maximum of 2 magnets
Measurement parameters	
Resolution	Controller dependent
Cycle time	Controller dependent
Linearity	≤ ±0.02 % F.S. (minimum ±90 µm)
Repeatability	≤ ±0.005 % F.S. (minimum ±20 µm)
Operating conditions	
Operating temperature	-40...+75 °C (-40...+167 °F)
Humidity	90 % rel. humidity, no condensation
Ingress protection <sup>1,2</sup>	IP67 (if mating cable connector is correctly fitted)
Shock test	100 g (single shock) IEC standard 60068-2-27
Vibration test	8 g / 10...2000 Hz IEC standard 60068-2-6 (resonance frequencies excluded)
EMC test	Electromagnetic emission according to EN 61000-6-3 Electromagnetic immunity according to EN 61000-6-2 The sensor meets the requirements of the EC directives and is marked with <b>CE</b> .
Magnet movement velocity	Any
Design / Material	
Sensor lid	Zinc die-cast
Sensor profile	Aluminum
Stroke length	50...3000 mm (2...118 in.)
Mechanical mounting	
Mounting position	Any
Mounting instruction	Please consult the technical drawings and the brief instructions (document number: <a href="#">551684</a> )
Electrical connection	
Connection type	M12 (8 pin) male connector
Operating voltage	+24 VDC (-15 / +20 %); UL recognition requires an approved power supply with energy limitation (UL 61010-1), or Class 2 rating according to the National Electrical Code (USA) / Canadian Electrical Code.
Ripple	≤ 0.28 V <sub>pp</sub>
Current consumption	50...100 mA
Dielectric strength	500 VDC (DC ground to machine ground)
Polarity protection	Up to -30 VDC
Overvoltage protection	Up to 36 VDC

1/ The IP rating is not part of the UL recognition

2/ The IP rating IP67 is only valid for the sensors electronics housing, as water and dust can get inside the profile

## TECHNICAL DRAWING

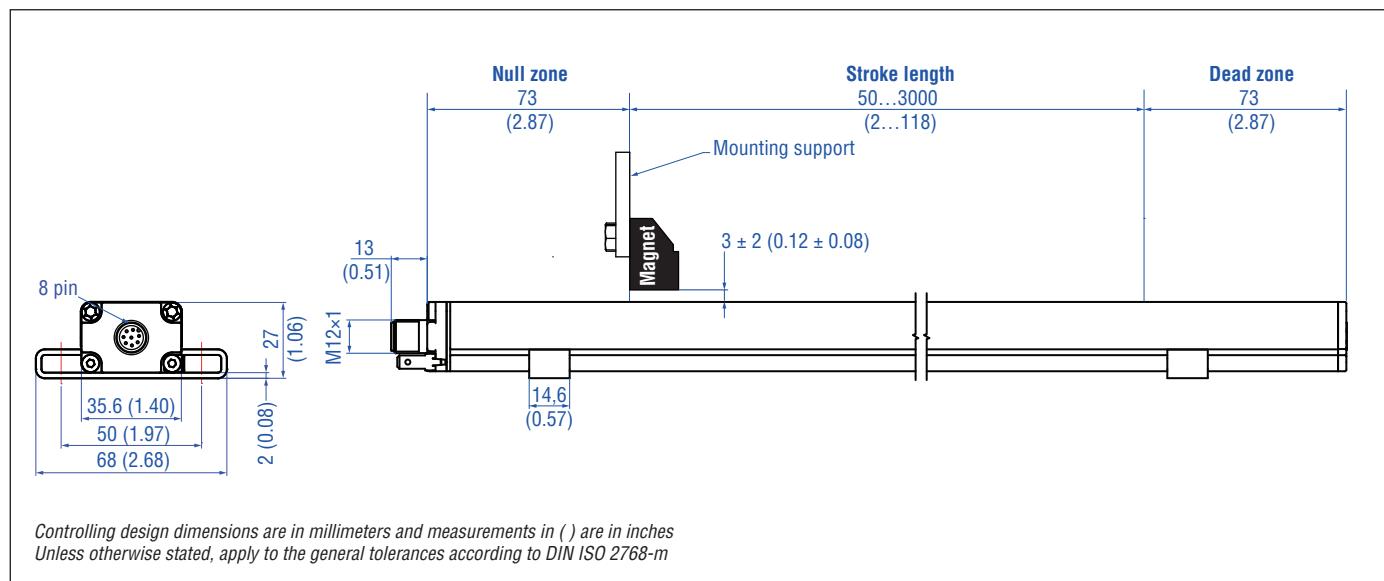

## CONNECTOR WIRING

### D84

M12 A-coded	Pin	Function
	1	Start (+)
	2	Start (-)
	3	Stop (+)
	4	Stop (-)
	5	Not connected
	6	Not connected
	7	+24 VDC (-15 / +20 %)
	8	DC Ground (0 V)

**FREQUENTLY ORDERED ACCESSORIES** – Additional options available in our [Accessories Guide](#) 551444

**Position magnet**      **Cable connectors<sup>3</sup>**

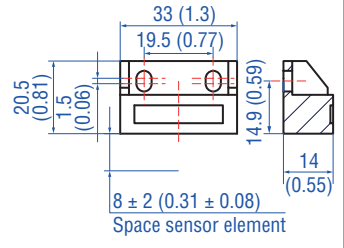
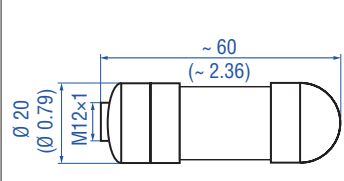
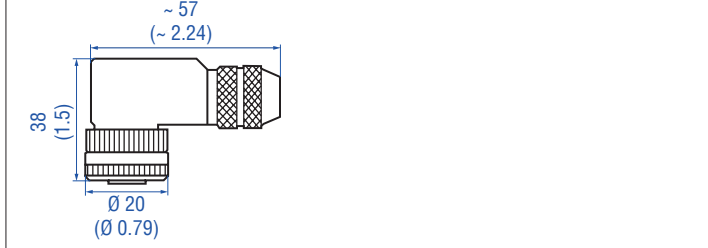
		
<p><b>Block magnet L</b> <b>Part no. 403 448</b></p> <p>Material: Hard ferrite Weight: Ca. 20 g Operating temperature: -40...+75 °C (-40...+167 °F) Fastening torque for M4 screws: 1 Nm</p>	<p><b>M12 (8 pin) female, straight</b> <b>Part no. 370 694</b></p> <p>Housing: GD-ZnAL / IP67 Termination: Screw; 0.75 mm<sup>2</sup> Contact insert: CuZn Cable Ø: 4...9 mm (0.16...0.35 in.) Fastening torque: 0.6 Nm</p>	<p><b>M12 (8 pin) female, angled</b> <b>Part no. 370 699</b></p> <p>Housing: GD-ZnAL / IP67 Termination: Screw; max. 0.5 mm<sup>2</sup> Contact insert: CuZn Cable Ø: 6...8 mm (0.24...0.31 in.) Fastening torque: 0.6 Nm</p>

**Cord sets**      **Mounting clamp**

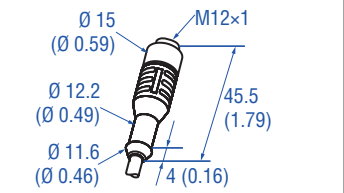
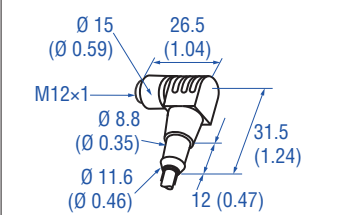
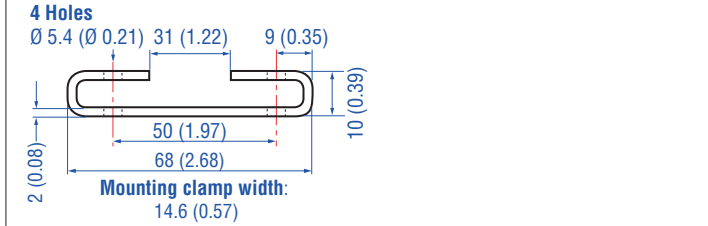
		
<p><b>M12 (8 pin) female, straight</b> <b>Part no. 370 674</b></p> <p>Ingress protection: IP67 Cable: Shielded, pigtail end Cable length: 5 m (16.4 ft.)</p>	<p><b>M12 (8 pin) female, angled</b> <b>Part no. 370 676</b></p> <p>Ingress protection: IP67 Cable: Shielded, pigtail end Cable length: 5 m (16.4 ft.)</p>	<p><b>Mounting clamp</b> <b>Part no. 403 508</b></p>

Controlling design dimensions are in millimeters and measurements in ( ) are in inches  
3/ Follow the manufacturer's mounting instructions when connecting the connectors

## ORDER CODE

1	2	3	4	5	6	7	8	9	10	11	12	13	14
E	P	2						D	8	4	1	R	3
a			b					c			d	e	

<b>a</b>	<b>Sensor model</b>
E P 2	Smooth profile

<b>b</b>	<b>Stroke length</b>
X X X X M	0050...3000 mm
X X X X U	002.0...118.0 in.

### Standard stroke length (mm)\*

Stroke length	Ordering steps
50 ... 500 mm	25 mm
500 ... 2500 mm	50 mm
2500...3000 mm	100 mm

### Standard stroke length (in.)\*

Stroke length	Ordering steps
2 ... 20 in.	1.0 in.
20...100 in.	2.0 in.
100...118 in.	4.0 in.

<b>c</b>	<b>Connection type</b>
D 8 4	M12 (8 pin) male connector

<b>d</b>	<b>Operating voltage</b>
1	+24 VDC (-15 / +20 %)

<b>e</b>	<b>Output</b>
R 3	Start / Stop with sensor parameters upload function

## DELIVERY



- Sensor
- 2 mounting clamps up to 1250 mm (50 in.) stroke length
- + 1 mounting clamp for each 500 mm (20 in.) additional stroke length

Accessories have to be ordered separately.

Operation manuals & software are available at:  
[www.mtssensors.com](http://www.mtssensors.com)

\* / Non standard stroke lengths are available; must be encoded in 5 mm / 0.1 in. increments

**UNITED STATES** 3001 Sheldon Drive  
MTS Systems Corporation Cary, N.C. 27513  
Sensors Division Phone: +1 919 677-0100  
E-mail: info.us@mtssensors.com

---

**GERMANY** Auf dem Schüffel 9  
MTS Sensor Technologie 58513 Lüdenscheid  
GmbH & Co. KG Phone: +49 2351 9587-0  
E-mail: info.de@mtssensors.com

---

**ITALY** Phone: +39 030 988 3819  
Branch Office E-mail: info.it@mtssensors.com

---

**FRANCE** Phone: +33 1 58 4390-28  
Branch Office E-mail: info.fr@mtssensors.com

---

**GREAT BRITAIN** Phone: +44 79 44 15 03 00  
Branch Office E-mail: info.uk@mtssensors.com

---

**CHINA** Phone: +86 21 6485 5800  
Branch Office E-mail: info.cn@mtssensors.com

---

**JAPAN** Phone: +81 42 707 7710  
Branch Office E-mail: info.jp@mtssensors.com

---

**Document Part Number:**  
551335 Revision D (EN) 03/2018



[www.mtssensors.com](http://www.mtssensors.com)