

Operation Manual

HE-Series Analog

Magnetostrictive Linear Position Sensors



Table of contents

1. Introduction	3
1.1 Purpose and use of this manual	3
1.2 Used symbols and warnings	3
2. Safety instructions	3
2.1 Intended use.....	3
2.2 Foreseeable misuse.....	3
2.3 Installation, commissioning and operation.....	4
2.4 Safety instructions for use in explosion-hazardous areas	4
2.5 Warranty.....	4
2.6 Return	4
3. Identification	5
3.1 Order code	5
3.2 Nameplate	6
3.3 Scope of delivery.....	6
4. Product description and commissioning	6
4.1 Functionality and system design	6
5. Installation instruction and design properties of HE series sensors	7
5.1 Selection of design.....	7
5.2 Installation – Type A (for internal mounting)	11
5.3 Installation – Type B (for external mounting)	12
5.4 Installation – Type C (pressure fit flange embedded)	13
5.5 Installation – Type D (pressure fit flange internal).....	14
5.6 Installation – Type E (threaded flange external).....	15
5.7 Installation – Type F (pressure fit flange embedded).....	16
5.8 Securing the pressure fit flange in the cylinder	17
5.9 Mounting sensors using a M12 connector system.....	17
5.10 Mounting instructions for position magnet	18
5.11 Part order.....	18
5.12 Polarity.....	18
5.13 Pairing.....	18
5.14 Alignment spacer	18
5.15 Insertion of the magnet into its cavity	18
5.16 Electrostatic effects	19
5.17 Cylinder handling after sensor installation.....	19
5.18 Painting cylinders.....	20
5.19 Welding	21
5.20 Frequently ordered accessories.....	22
6. Operation	23
6.1 Getting started.....	23
7. Maintenance and troubleshooting	26
8. Removal from service / dismantling	26
9. Technical data	27
10. Appendix	28

1. Introduction

1.1 Purpose and use of this manual

Before starting the operation of MTS position sensors, read this documentation thoroughly and follow the safety information. Keep the manual for future reference!

The content of this technical documentation and its appendix is intended to provide information on mounting, installation and commissioning by qualified technical personnel ¹ or instructed service technicians who are familiar with the project planning and dealing with MTS position sensors.

1.2 Used symbols and warnings

Warnings are intended for your personal safety and for avoidance of damage to the described product or connected devices. In this documentation, safety information and warnings to avoid dangers that might affect the life and health of operating or service personnel or cause material damage are highlighted by the preceding pictogram, which is defined below.

Symbol	Meaning
NOTICE	This symbol is used to point to situations that may lead to material damage, but not personal injury.

2. Safety instructions

2.1 Intended use

This product may be used only for the applications defined under item 1 and only in conjunction with the third-party devices and components recommended or approved by MTS Sensors. As a prerequisite of proper and safe operation the product requires correct transport, storage, mounting and commissioning and must be operated with utmost care.

- The sensor systems of all MTS sensors are intended exclusively for measurement tasks encountered in industrial, commercial and laboratory applications. The sensors are considered as system accessories and must be connected to suitable evaluation electronics, e.g. a PLC, IPC, indicator or other electronic control unit.

2.2 Foreseeable misuse

Foreseeable misuse	Consequence
Wrong sensor connection	The sensor will not work properly or will be destroyed
Operate the sensor out of the operating temperature range	No signal output / The sensor can be damaged
Power supply is out of the defined range	Signal output is wrong / no signal output / the sensor will be damaged
Position measurement is influenced by an external magnetic field	Signal output is wrong
Cylinder bore hole too small	Component damage due to excessive installation force required.
Cylinder bore hole after welding too small	Component damage due to excessive installation force required.
Sharp edges	Damage to cables and conductors
Rough sensor handling	Destruction of internal components
Welding after installation	High energy voltage peaks or currents are fed to the sensor, damaging housing or electronic components.
Cables are damaged	Short circuit – the sensor can be destroyed / sensor does not respond
Loose connectors	Liquid can penetrate into the sensor into the sensor housing through cables or strands and cause short circuit or corrosion of electronics components
Spacers are missing or installed in a wrong order	Error in position measurement
Wrong connection of ground / shield	Signal output is disturbed / The electronics can be damaged
Use of a magnet that is not certified by MTS Sensors	Error in position measurement

Fig. 1: Foreseeable misuse

^{1/} The term qualified technical personnel characterizes persons who:

- are familiar with the safety concepts of automation technology applicable to the particular project,
- are competent in the field of electromagnetic compatibility (EMC),

- have received adequate training for commissioning and service operations
- are familiar with the operation of the device and know the information required for correct operation provided in the product documentation.

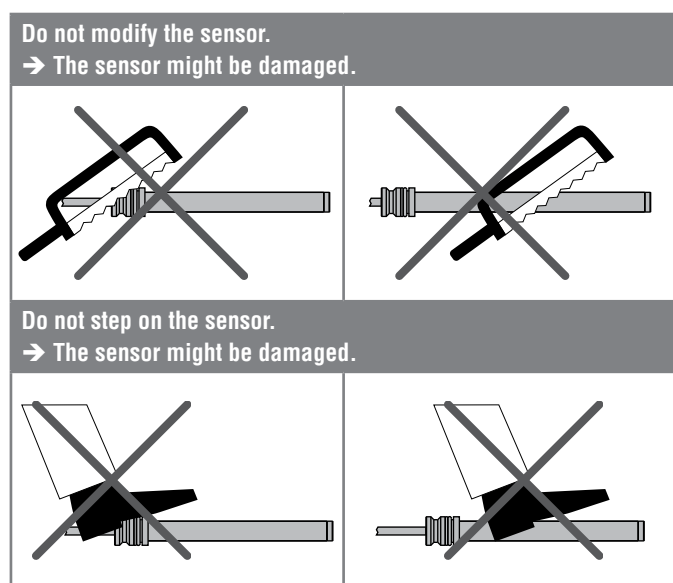

Fig. 2: Forseeable misuse in handling

2.3 Installation, commissioning and operation

The position sensors must be used only in technically safe condition. To maintain this condition and to ensure safe operation, installation, connection and service, work may be performed only by qualified technical personnel.

If danger of injury to persons or of damage to operating equipment is caused by sensor failure or malfunction, additional safety measures such as plausibility checks, limit switches, EMERGENCY STOP systems, protective devices etc. are required. In the event of trouble, shut down the sensor and protect it against accidental operation.

Safety instructions for commissioning

To maintain the sensor operability, it is mandatory to follow the instructions given below.

1. Protect the sensor against mechanical damage during installation and operation.
2. Do not open or dismantle the sensor.
3. Connect the sensor very carefully and pay attention to the polarity of connections and power supply.
4. Use only approved power supplies.
5. It is imperative that the specified permissible limit values of the sensor for operating voltage, environmental conditions, etc. are met.
6. Check the function of the sensor regularly and provide documentation of the checks.
7. Before applying power, ensure that nobody's safety is jeopardized by starting machines.

2.4 Safety instructions for use in explosion-hazardous areas

The sensor is not suitable for operation in explosion-hazardous areas.

2.5 Warranty

MTS Sensors grants a warranty period for the position sensors and supplied accessories relating to material defects and faults that occur despite correct use in accordance with the intended application². The MTS Sensors obligation is limited to repair or replacement of any defective part of the unit. No warranty can be provided for defects that are due to improper use or above average stress of the product, as well as for wear parts. Under no circumstances will MTS Sensors accept liability in the event of offense against the warranty rules, no matter if these have been assured or expected, even in case of fault or negligence of the company. MTS Sensors explicitly excludes any further warranties. Neither the company's representatives, agents, dealers nor employees are authorized to increase or change the scope of warranty.

2.6 Return

For diagnostic purposes, the sensor can be returned to MTS Sensors. Any shipment cost is the responsibility of the sender². For a corresponding form, see chapter 7 on page 26.

^{2/} See also applicable MTS Sensors terms of sales and delivery on: www.mtssensors.com

3. Identification

3.1 Order code

1	2	3	4	5	6	7	8	9	10	11	12	13	14	15	16
H	E	2					M								
a		b	c	d				e			f	g	h		

a	Sensor model	
H	E	Hall Effect

b	Design
2	2nd Generation

c	Flange
A	Threaded flange 9/16"-18 UNF (for internal mounting), AF 17.5
B	Threaded flange 3/4"-16 UNF (for external mounting), AF 24
C	Small pressure fit flange (14 mm)
D	Large pressure fit flange (20 mm)
E	Threaded flange M18×1.5 (for external mounting), AF 24
F	Small pressure fit flange (14.5 mm)

d	Stroke length			
X	X	X	M	100...500 mm (20 mm increments)

e	Connection type			
Single wires (for all flange options)				
N	0	4	40 mm	
N	0	6	60 mm	
N	0	8	80 mm	
N	1	0	100 mm	
N	1	2	120 mm	
N	1	4	140 mm	
N	1	6	160 mm	
N	1	8	180 mm	
N	2	0	200 mm	
N	2	2	220 mm	
N	2	4	240 mm	
N	2	5	250 mm (standard)	
PUR Cable (for all flange options)				
T	0	3	300 mm	
T	0	5	500 mm	
T	1	0	1000 mm	
T	2	0	2000 mm	
T	3	0	3000 mm	
T	5	0	5000 mm	

f	Cable / Wire / Pin termination
----------	---------------------------------------

For all flange options

A	Cable / wire assignment "A"
---	-----------------------------

With flange option "D" (M12 connector)

E	Pin assignment "E"
G	Pin assignment "G"
H	Pin assignment "H"

g	Operating voltage
----------	--------------------------

3	+5 / 12 / 24 VDC (4.75...32 VDC)
---	----------------------------------

h	Output
----------	---------------

V	1	2	0.5...4.5 VDC
---	---	---	---------------

A	0	1	4...20 mA
---	---	---	-----------

3.2 Nameplate

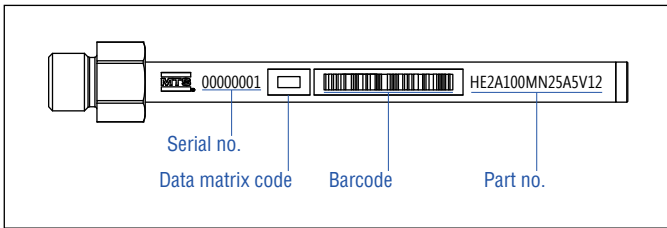

Fig. 3: Nameplate

3.3 Scope of delivery

Cable

- **HE-2-A, HE-2-B, HE-2-E (threaded flange):**
Sensor, O-ring, magnet assy
- **HE-2-C, HE-2-D, HE-2-F (pressure fit flange):**
Sensor, O-ring, back up ring, magnet assy

M12 connector system

- **HE-2-D (pressure fit flange with M12 system connector):**
Sensor, O-ring, back up ring, M12 system connector incl. flange assy, magnet assy
- **Magnet assy contains of:**
Magnet, plastic spacer, O-ring, metal spacer, snap ring

4. Product description and commissioning

4.1 Functionality and system design

Product designation

Position sensor HE-Series

Sensor model

- Type A:** Threaded flange, embedded
- Type B:** Threaded flange
- Type C:** Pressure fit flange, embedded
- Type D:** Pressure fit flange, embedded
- Type E:** Threaded flange
- Type F:** Pressure fit flange, embedded

Stroke length

100...500 mm in 20 mm increments

Output signal

Analog (voltage/current)

Model sensor

The HE-series sensors utilizing Hall Effect technology are specifically designed for direct stroke measurement in hydraulic cylinders. With virtually no dead zone, tight pin to pin measurements can be achieved. HE-series sensors can be fully sealed and embedded in a cylinder that provides excellent protection against the environment and EMI and ensures a long operating life. With six different mounting styles, HE-series sensors can be installed externally from the head side or internally from the rod side of the cylinder depending on the cylinder design. An optional MTS M12 connector system ensures protection to IP69K. Analog signal outputs are available.

Principle of operation and system construction

MTS Sensors linear position sensors utilizing Hall Effect technology are able to determine position with a high level of repeatability and robustness. The sensors consist of a sensing element, a position magnet and supporting electronics. The sensing element is powered by electric current. The position magnet is attached to the object in motion for the given application. The magnet's field component perpendicular to the sensing element creates a measurable voltage which is proportional to the strength of the magnetic field that is converted into a linear position measurement. Since the output from the sensor corresponds to an absolute position, rather than a relative value, recalibration is not required.

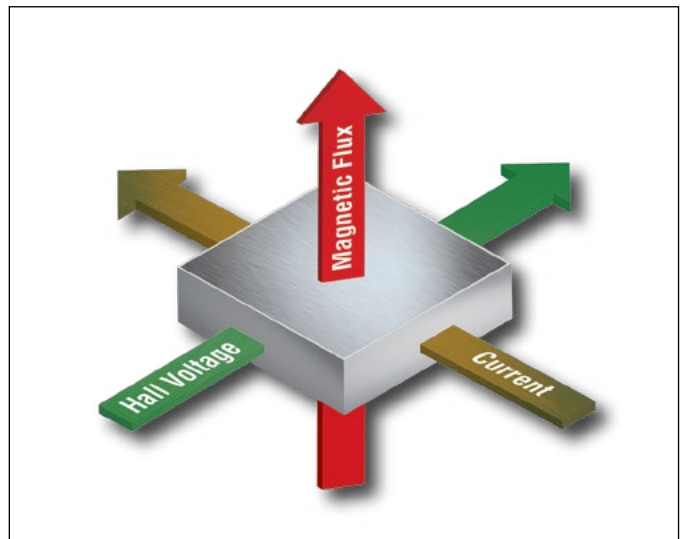

Fig. 4: Hall Effect principle

5. Installation instruction and design properties of HE series sensors

5.1 Selection of design

The appropriate sensor housing type has to be selected according to the requirements of application and cylinder design.

5.1.1 Selection of sensor stroke length, positioning into the cylinder, active measuring range

NOTICE

The sensor's electrical stroke length and the placing in the cylinder must be selected in a way such that the end positions of the cylinder stroke are completely covered by the electrical signal, taking into account all production tolerances.

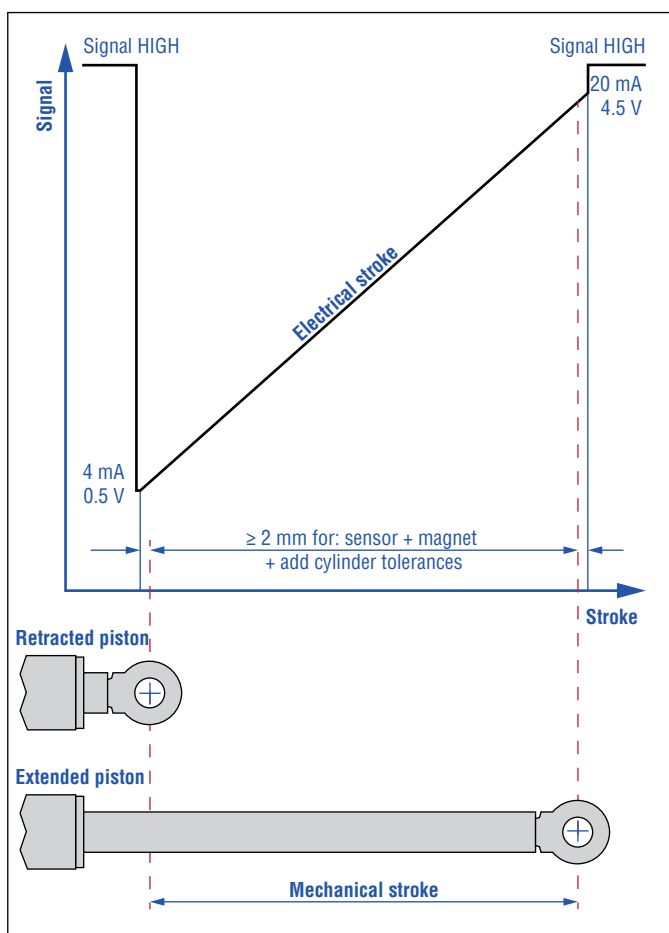

Fig. 5: Set point tolerance

NOTICE

For a requirement of 100 mm mechanical stroke, please use a sensor at 120 mm electrical stroke.
Please place the sensor with a reserve of ≥ 2 mm next to one of the set points according to the scheme.

5.1.2 Electrical stroke

NOTICE

The embedding of the position magnet components in ferromagnetic material (zone 1) must be followed according to the geometry of Fig. 6:

- Use ferromagnetic standard materials in the construction of cylinders (like e.g. C45, 11SMnPb30)
- The position magnet must be seated flush on the shoulder of primary bore diameter.
- If you have any questions, contact our application engineering department
- The length and drill diameters (including tolerances) must be followed

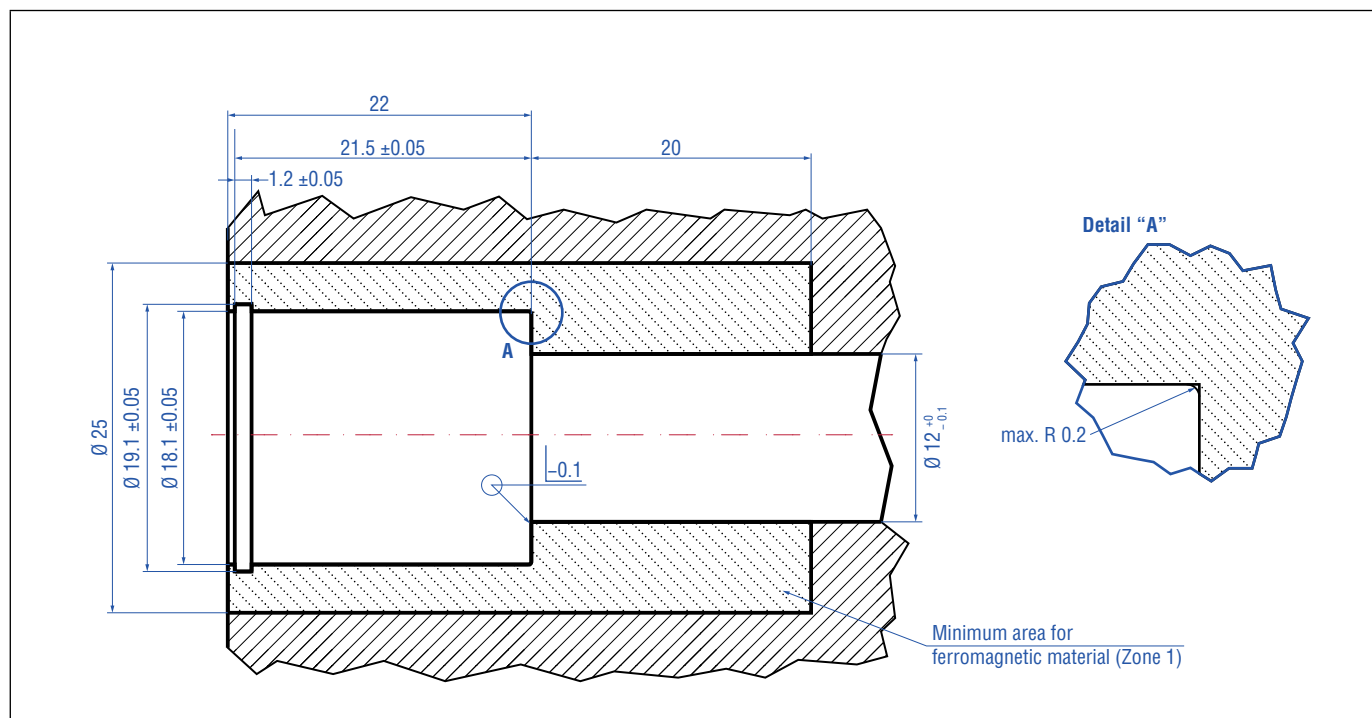

Fig. 6: Ferromagnetic material

5.1.3 Component boundaries

NOTICE

If necessary, use the back of the magnet to define the boundary location.

5.1.4 Concentricity

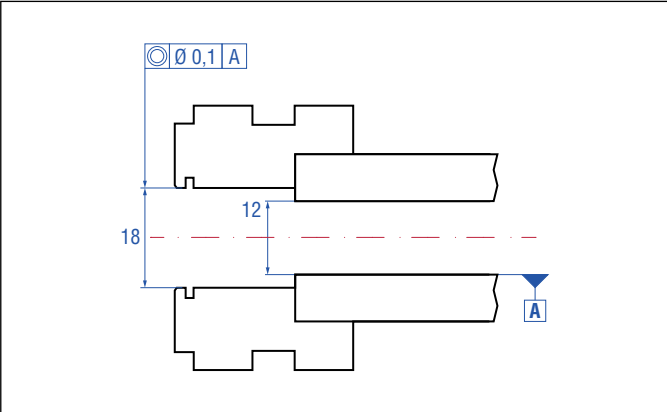

Fig. 7: Concentricity of the bore hole

NOTICE

- The component design must be chosen in such way that it is in accordance to the scheme as shown.
- Tolerance of concentricity of stepped bore for the position magnet for deep hole drilling

5.1.5 Positioning of back-up and O-ring

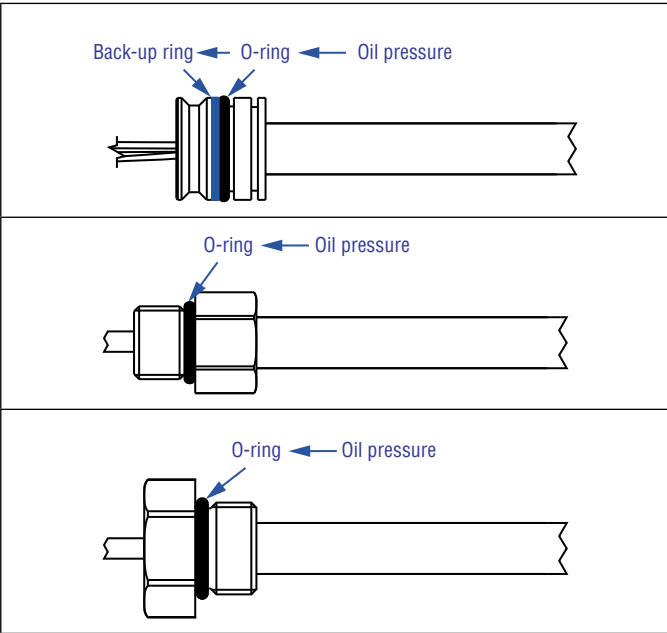

Fig. 9: Positioning of back-up and O-ring

5.1.6 Further design criteria to consider

Required feed-in chamfer

- For correct and easy sensor mounting in the cylinder, a chamfered edge as shown in the drawing is required. To avoid damaging the o ring during installation, the radius at the transition from bore hole to chamfered edge must be R0.6 – R1. Without this radius, there would be a sharp edge, which could damage the O-ring.
- Recommend 20 degree lead in angle

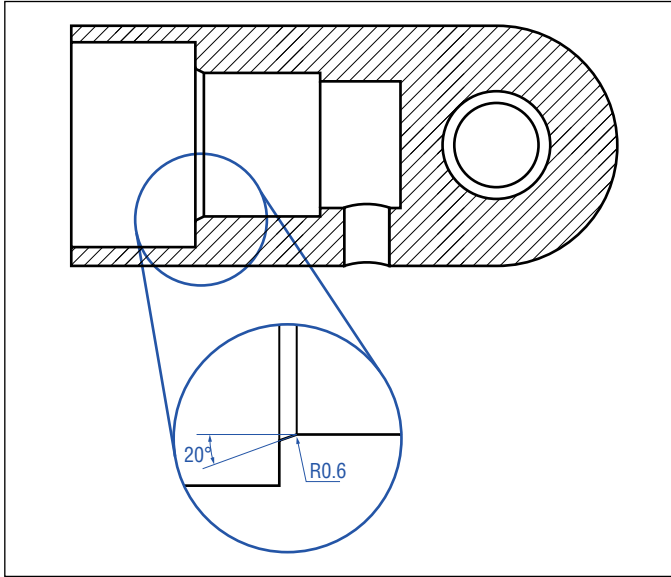

Fig. 8: Required feed-in chamfer

Other criteria:

- Notice > 3 mm clearance in the deep drilling hole
- Notice correct fit and tolerance

5.1.7 CAD data

CAD models are available at www.mtssensors.com.

5.1.8 Mounting instruction

General

- Tighten threaded components to designated torque specifications
- Grease thread, plug-in flange and seals for sensor insertion!
- Pay attention to the correct positioning of the sensor! Avoid mechanical damage to machined surfaces and threads
- When installing the piston rod, make sure that parts of the magnet assembly will not get damaged
- Notice sensor's bearing surfaces! Use suitable mounting aids if necessary

Connection cable assembly

- Route the connection cable through the cylinder wall carefully.
- Choose suitable strain relief and sealing according to environmental requirements (e.g. by selecting a well-fitting cable gland)
- When mounting the sensor or connecting parts, e.g. cable gland avoid excessive mechanical stress by twisting or pulling the sensor cable
- Never expose the connecting cable to tensile stress and protect it against sharp edges, which might damage the insulation of the connecting cables!
- Do not carry the sensor or cylinder through holding the cable!

Threaded flanges

- If necessary, use a suitable release agent.

Pressure fit flanges

- Fix the sensor in the cylinder, using the recommended set screw, to protect from falling out in case of vacuum.

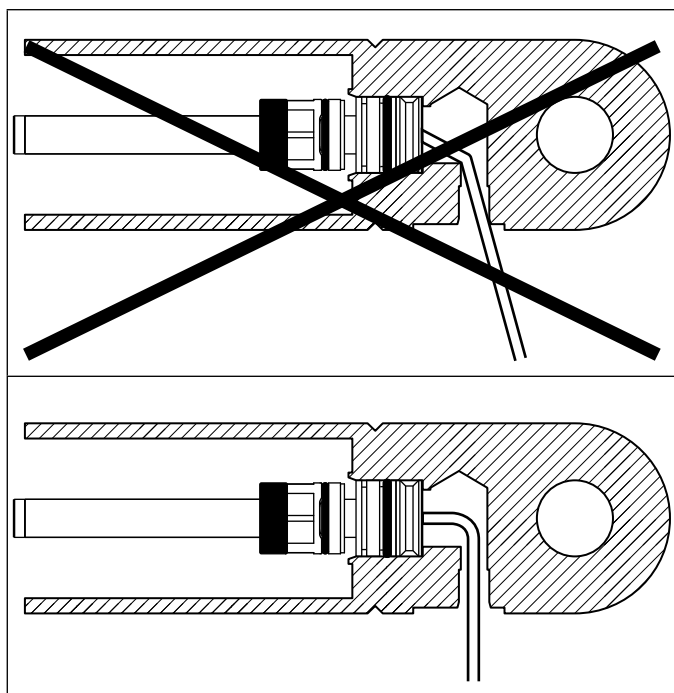

Fig. 10: Routing of the connecting cables

5.2 Installation – Type A (for internal mounting)

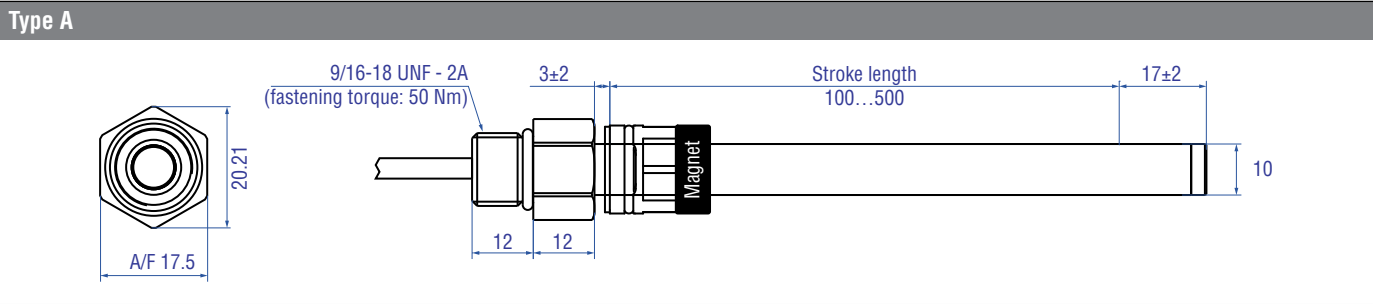

Fig. 11: HESensor Type A

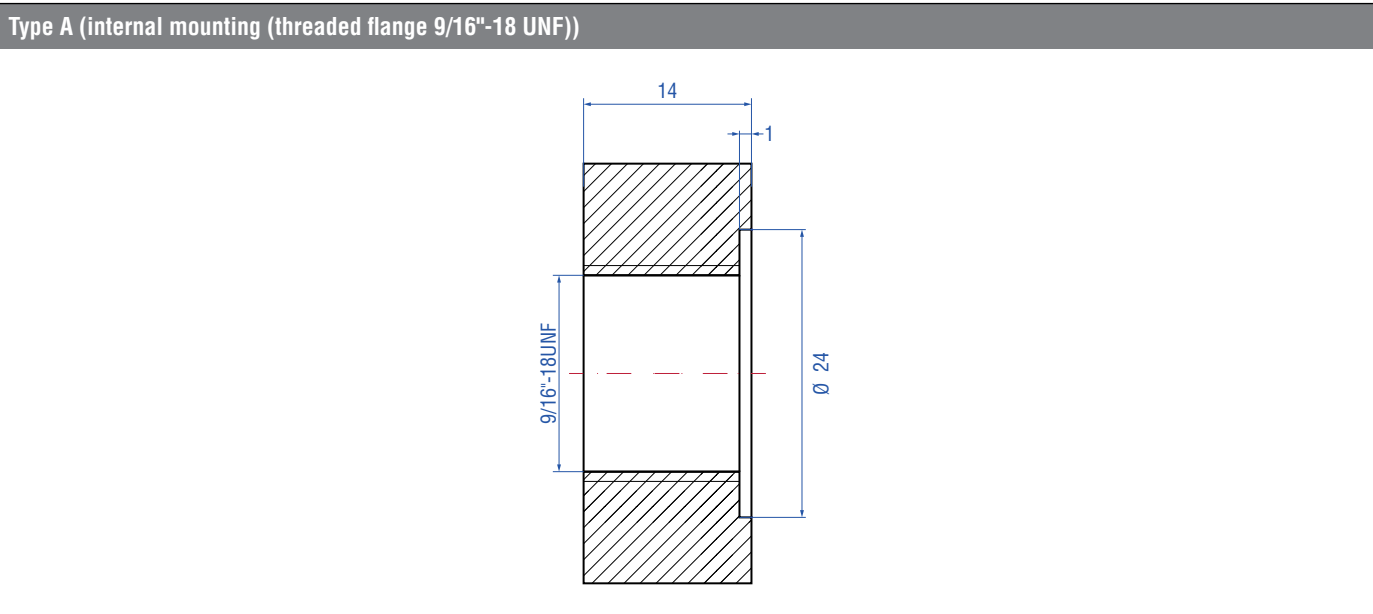

Fig. 12: Internal thread in cylinder

NOTICE
In-cylinder installation fastening torque: 50 Nm (+10 %)

Controlling design dimensions are in millimeters

5.3 Installation – Type B (for external mounting)

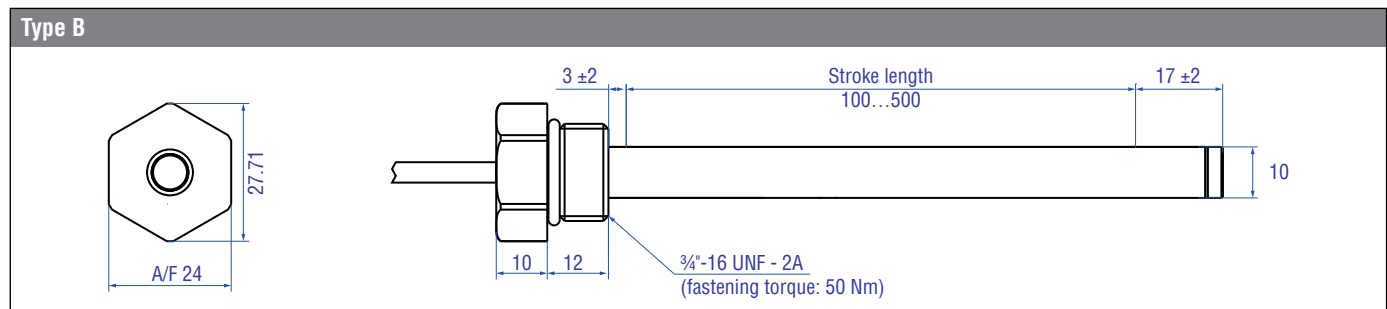

Fig. 13: HE Sensor Type B

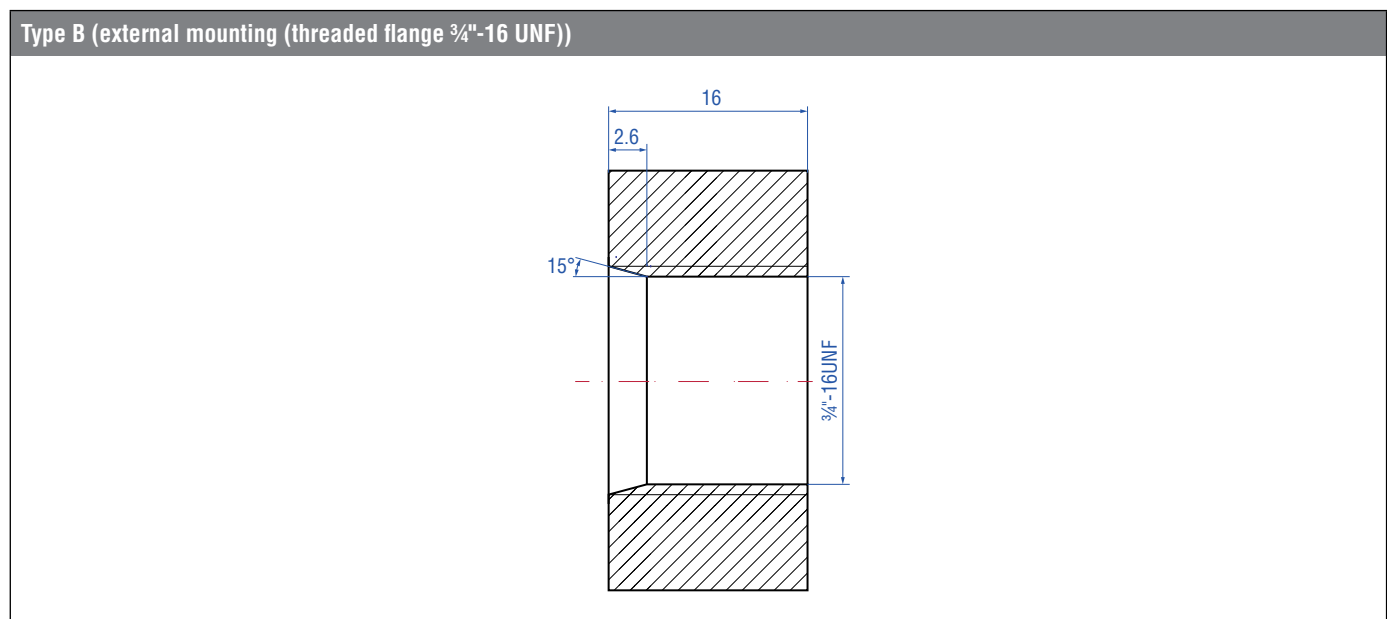

Fig. 14: Internal thread in cylinder

NOTICE
 In-cylinder installation fastening torque: 50 Nm (+10 %)

5.4 Installation – Type C (pressure fit flange embedded)

Type C

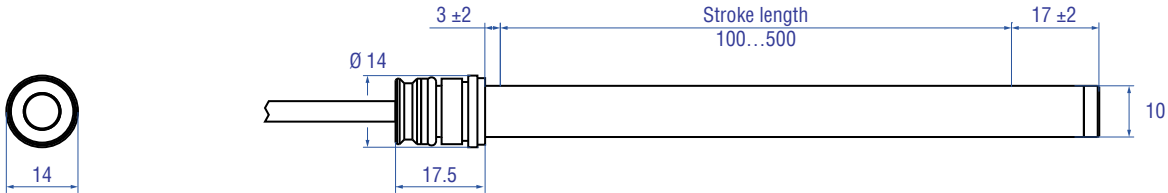

Fig. 15: HE Sensor Type C

Type C (pressure fit flange Ø 14 mm)

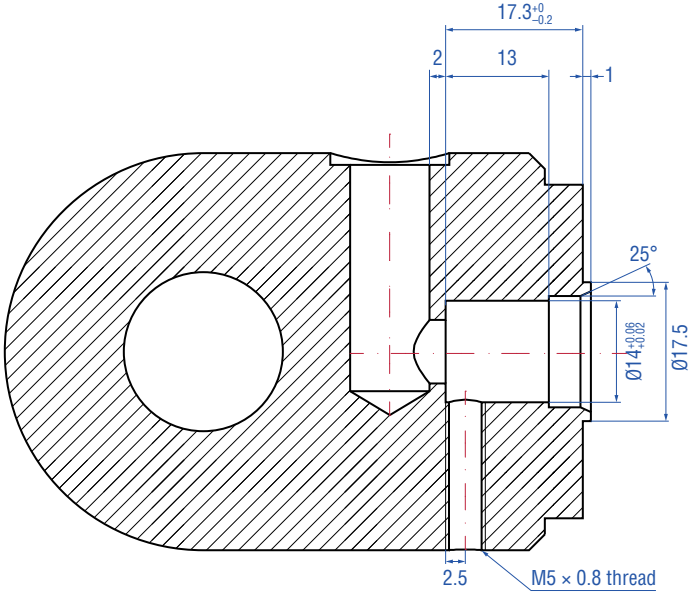

Fig. 16: Cavity fit in cylinder

Controlling design dimensions are in millimeters

5.5 Installation – Type D (pressure fit flange internal)

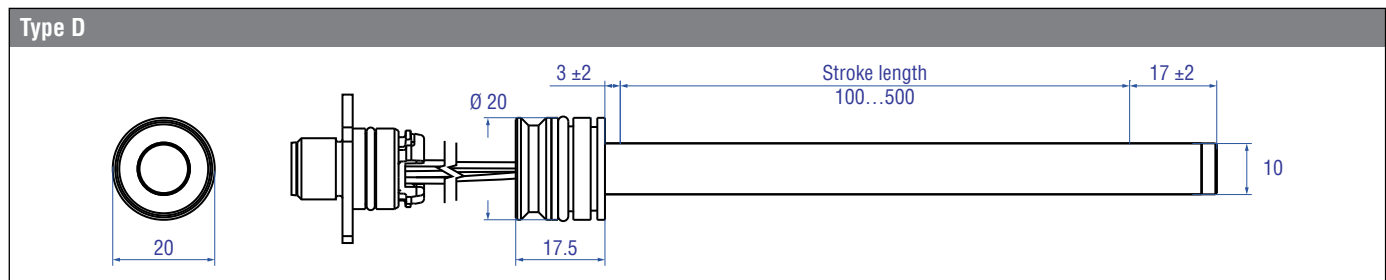

Fig. 17: HE Sensor Type D

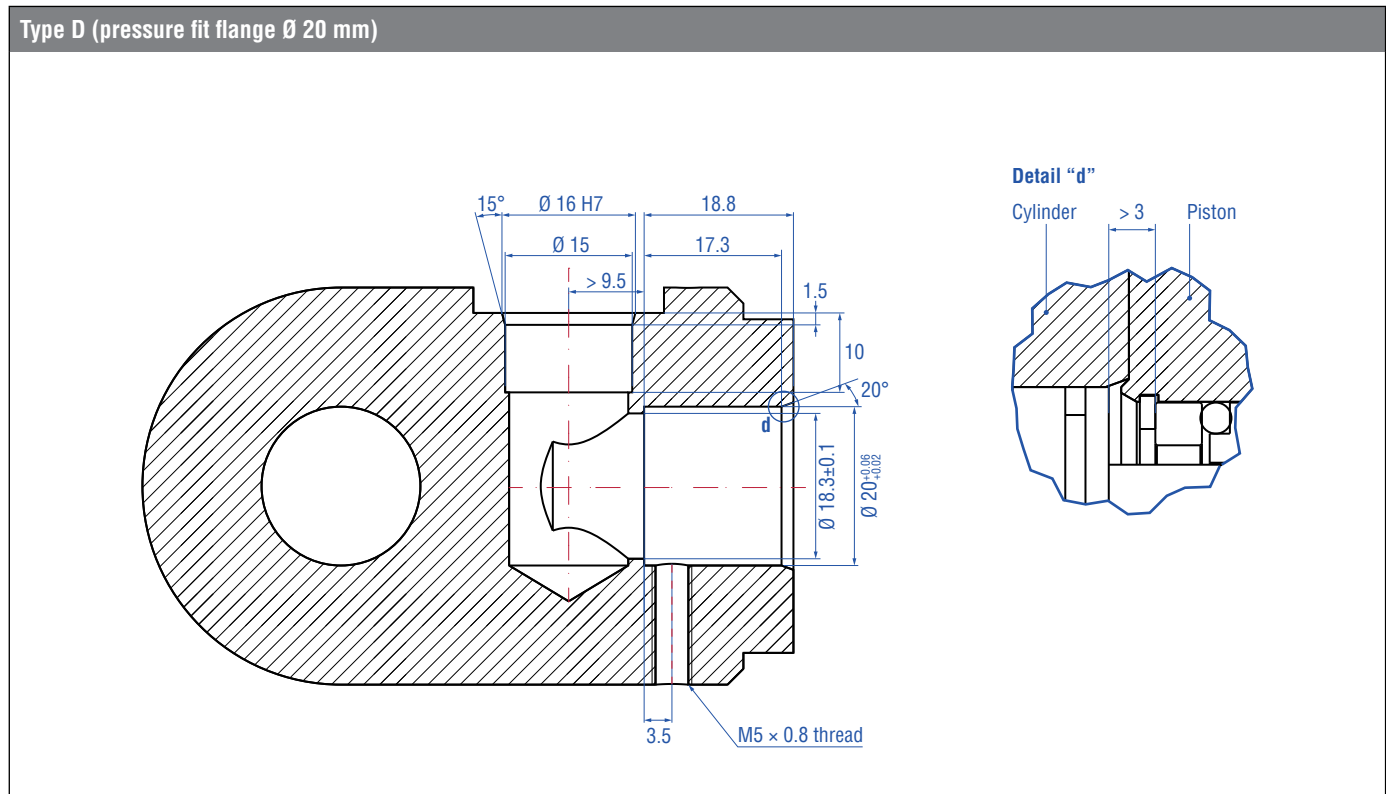

Fig. 18: Cavity fit in cylinder

Controlling design dimensions are in millimeters

5.6 Installation – Type E (threaded flange external)

Type E

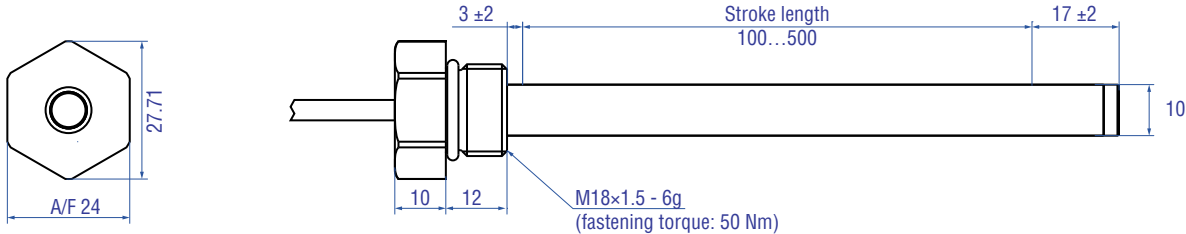

Fig. 19: HE Sensor Type E

Type E (external mounting (threaded flange M18x1.5))

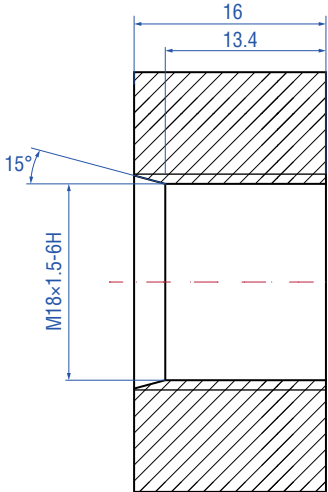

Fig. 20: Internal thread in cylinder

Controlling design dimensions are in millimeters

5.8 Securing the pressure fit flange in the cylinder

- Fix the embedded pressure fit flange sensor with a M5 set screw (according to DIN 913) in the cylinder
- Fastening torque: 0.5 Nm when using soluble anaerobic adhesive (e.g. Loctite blue)

5.9 Mounting sensors using a M12 connector system

The M12 connector system is connected to the sensor and ready for installation. After installation in the cylinder and inserting the mating plug, it meets the high requirements of protection class IP68 and IP69K. Soldering, screwing or crimping is not necessary. The risk of contact faults, corrosion of contacts and faulty connection is also omitted. When you select suitable mating plugs, make sure that these plugs are also protected to IP68 or IP69K, because this protection class can only be ensured if suitable mating plugs are used.

Recommended M4 cylinder head screws with pan head, max. Ø 7 mm:

- Button head screw (according to ISO 7380)
- Hexagon socket head cap screw (according to DIN 912)
- Hexalobular socket cylinder head screw (according to ISO 14580)
- Slotted screw (according to DIN 84)
- Comparable cross-head screw
- Comparable thread-forming screws

Screws should be inserted using resolvable safety adhesive. Alternatively, mounting can be done using a round head rivet (according to DIN 660).

Non-recommended screws:

- Hexagon head screws
- Countersunk/flat head screws
- Self-tapping screws

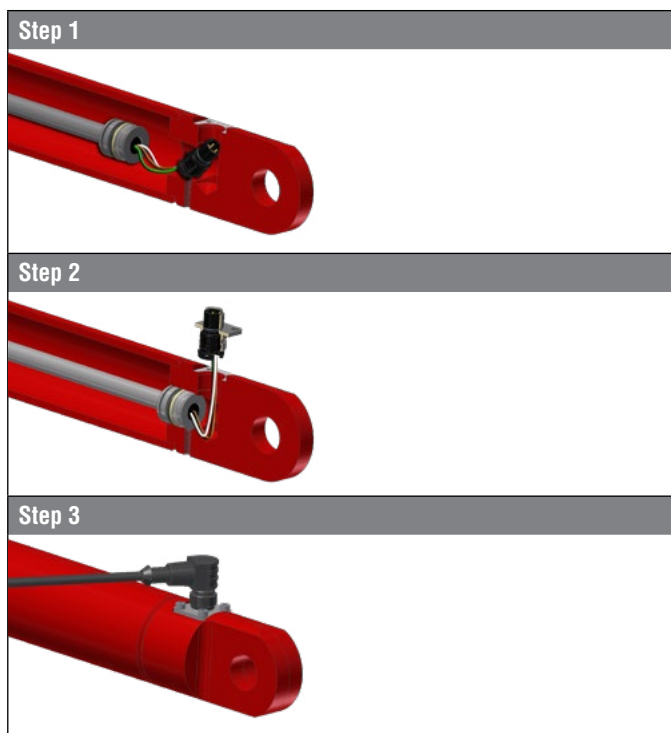

Fig. 23: M12 connector system

5.10 Mounting instructions for position magnet

- The magnet has a strong magnetic force
- Avoid impacts
- Check installation in its intended fit cavity
- Use appropriate mounting aid if necessary
- Avoid overheating
- Lubricate the parts before assembly

5.11 Part order

The position magnet is supplied as an assembly, which is ensuring the functioning of the sensor through its part sequence.

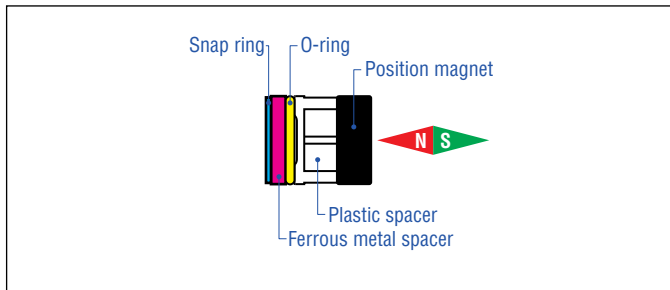

Fig. 24: Part order of magnet

NOTICE

The part order of the magnet assembly components as shown in the figure is mandatory for the function. All parts supplied must be used.

5.12 Polarity

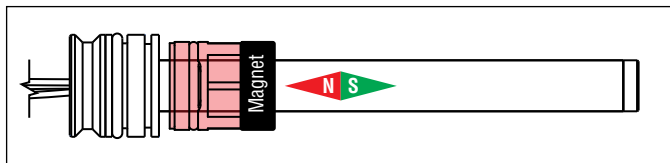

Fig. 25: Polarity of magnet

NOTICE

The orientation of the polarity is important. The magnet is axially magnetized. On the magnet, the magnetic north pole is marked with a white dot and must be oriented as shown. In case of doubt, use a polarity tester.

5.13 Pairing

The sensor is matched to the magnet which is equipped at delivery.

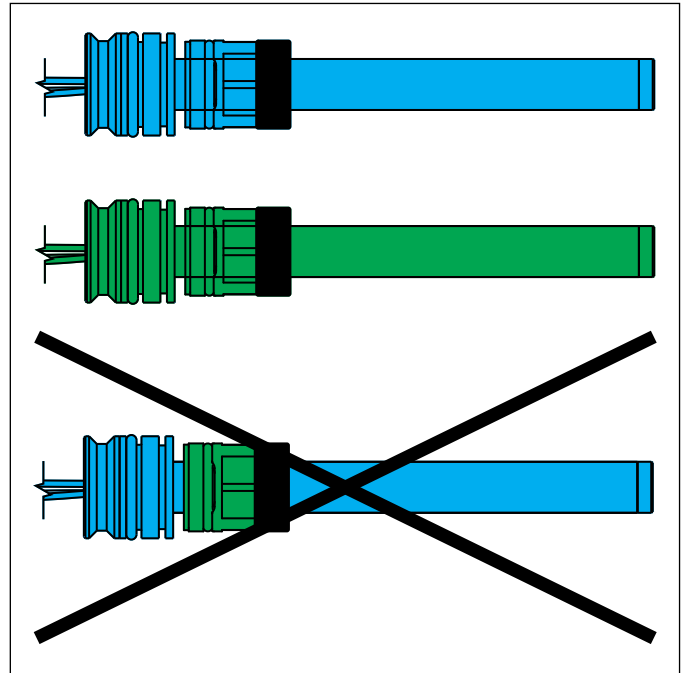

Fig. 26: Use of sensor and magnet as a pair

NOTICE

The pairing of magnet and sensor as provided in the delivery state must be kept in the installed state.

5.14 Alignment spacer

The spacer has a chamfer which eases the assembly.

NOTICE

The non-magnetic spacer provides alignment to the sensor rod and is designed to touch the sensor rod surface.

5.15 Insertion of the magnet into its cavity

Let the position magnet slide smoothly and carefully into its cavity. Grease the parts

NOTICE

Avoid shocks.

5.16 Electrostatic effects

Electrostatic charge is caused due to friction and separation of charge. This phenomenon is widely known and can be produced e.g. by carpets or car seats. Mostly, the charge is noticed only in the event of discharge, when the associated „shock“ occurs. The voltages due to electrostatic discharge can have very high values, for example:

- Walking over carpet floors up to 30,000 V
- Walking over synthetic floors up to 12,000 V
- Moving at the workplace up to 6,000 V

Not only the high voltages, but especially the sudden discharge and related currents (up to 50 Ampere!) can cause destruction of electrical components. The effects are similar to those occurring due to electrostatic discharge during dry painting.

Current flow curve during electrostatic discharge of a human body

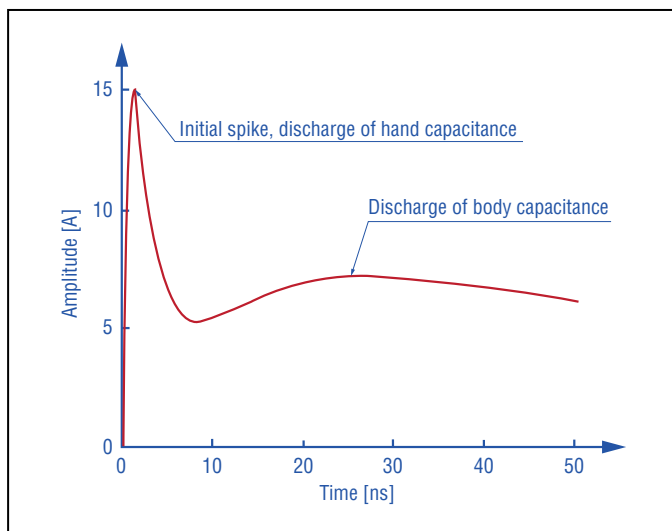

Fig. 27: Current flow curve during electrostatic discharge of a human body

To avoid electrostatic discharge, workplaces and persons working with or on electronic components must be grounded. This also applies to sensor installation into the hydraulic cylinder as well mounting procedure the cylinder to the machine.

Suitable protective measures are:

- Persons wear ribbons connected to the grounding point by means of spiral cable around their wrist. Please, contact us, if you need information on suppliers for suitable protective equipment.
- Work is only performed on diverting material, i.e. charges can be diverted gently (e.g. work plate of wood, rubber, ESD foam material).
- Avoid hard discharge. Do not deposit components on metal plates or metal film.
- Do not remove electrostatically sensitive components from the packaging without grounding.
- Caution when cutting adhesive tapes, do not tear to open.

5.17 Cylinder handling after sensor installation

Washing and drying cylinders with installed sensors

Frequently, hydraulic cylinders are washed or degreased before painting. For this purpose, various chemical and/or thermal methods are used, whereby cleaning agents are sprayed onto the components under high pressure up to 50 bar. During this procedure, the following measures relating to polyurethane (PUR) connecting cables and plug-in connections must be taken.

Sensors with M12 connector system

- When washing at low pressures up to approx. 5 bar, the plastic cap supplied with sensor and connector system is sufficient to protect the M12 connector system (part no. 403287).
- When washing at higher pressures, an M12×1 metal protective device should be used to protect the connector system against the effect of chemicals.
- The actual MTS connector system won't be damaged due to its high protection class, however, mating plugs which are connected subsequently might corrode due to the effect of chemicals.
- If temperatures higher than +85 °C are used for drying after washing, the connector systems should not be exposed to this temperature for more than about 5 minutes.

Sensors with connecting cable

- Protect the connecting cables using suitable enclosures (e.g. bags) against the effect of moisture, high pressures and temperatures.
- Normally, cable entry glands meet the requirements of IP67, however, they are not pressure-tight. For this reason, they must be protected against moisture as well, in order to prevent moisture from accumulating in the connecting compartment of the cylinder.
- MTS connecting cables are made of PUR and relatively resistant against a large variety of chemicals and oils. However, exceptions are e.g. carbon tetrachloride, trichloroethylene, perchloroethylene, which can be ingredients of fat solvents and cleaning agents.
- Therefore, make sure that cables are protected adequately, if cleaning agents that can attack PUR are used.
- If temperatures higher than +85 °C are used for drying after washing, the connecting cables shouldn't be exposed to this temperature for more than 5 minutes.

5.18 Painting cylinders

Electrostatic painting

Various dry and wet methods of applying paint to the component surface use electrostatic charge to paint cylinders. These methods employ very high voltages up to 100 kV, which can damage the electronics of position measuring systems. To prevent this damage, it is mandatory to take the following measures during electrostatic painting.

- Attach the cylinder to the painting frame by the barrel side of the cylinder rather than by the piston rod. The reason is that the integrated sealing and slide rings can cause electric isolation between the piston rod and the cylinder/sensor housing, i.e. low-impedance connection between the painting equipment ground and the sensor housing is not ensured.
- Clean the suspension points at the painting system and all connections used for short-circuiting conductors and connection to the painting system ground regularly and remove paint as well as other residues, in order to ensure low-impedance connection.

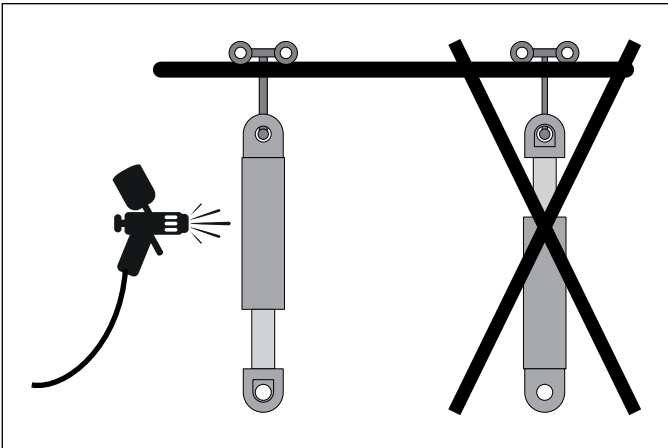

Fig. 28: Electrostatic painting

Cylinders with integrated sensors and M12 connector system

When using dry or powder painting methods for cylinders, powder is applied to the component surface by means of static charge. These methods employ very high voltages that can damage the electronics of MTS position measuring systems integrated in the cylinders. This can be prevented using the following metal protective caps.

The metal protective cap safeguards the contact pins and thus the electronics of the sensor against electrostatic effects (high voltage). It is important to note that:

- The material of the protective cap must be permanently electrically conductive.
- The cap must not be of aluminum (aluminum is subject to oxidation and can cause electric isolation).
- The metal protective cap must have an M12×1 thread.
- The cap must be screwed up to the connector flange plate.
- Make sure that no paint particles contaminate the thread or the contact pins.
- The thread of the protective cap must be clean and free from paint particles and other substances at all times.
- The metal protective cap must be tightened only so that it is hand-tight (max. 5 Nm).
- Paint particles on the cap outside are of no concern.
- Drawing examples for the protective cap are given in the attachment.

Cylinders with integrated sensors

- Electrostatic painting cannot be used for sensors with connecting cables, since the cable cannot be protected safely against the high process voltage. Safe electrostatic painting is ensured only in conjunction with the M12 connector system and the brass caps.

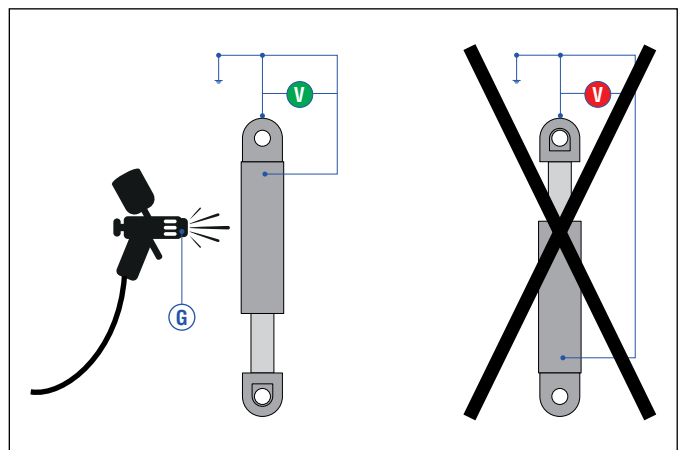

Fig. 29: Electrostatic painting of cylinders with integrated sensors

5.19 Welding

After installing the cylinder in machines, welding work on adjacent components can be necessary. If a grounding clamp is applied directly or too closely to the cylinder, welding currents can be transmitted to the sensor via the cylinder and cause burning of the sensor pipe or damage of internal sensor components. Cylinders mostly consist of two assemblies: the lower part with the cylinder pipe and the piston with the piston rod. These components are isolated electrically from each other by gaskets, bearings and slide rails. This means that, normally, no current flow is possible. With cylinders, however, the welding current may be transmitted from the piston to the cylinder pipe. In this case, an electrical connection causes the entire welding current to flow through the sensor pipe and the sensor head, thus damaging the electronics. Moreover, the cylinder and/or the gaskets are destroyed.

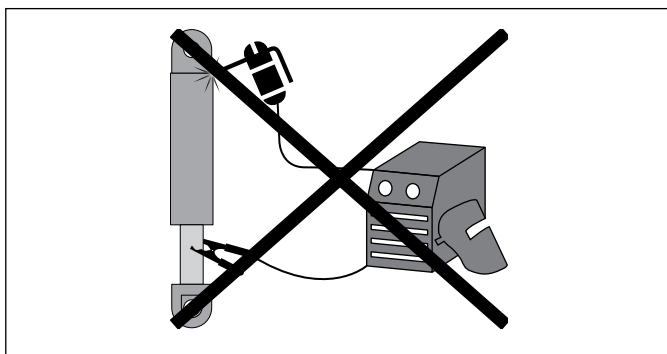

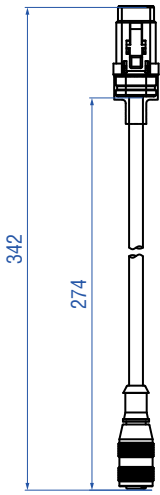
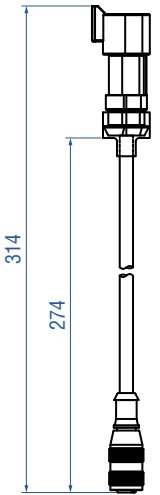
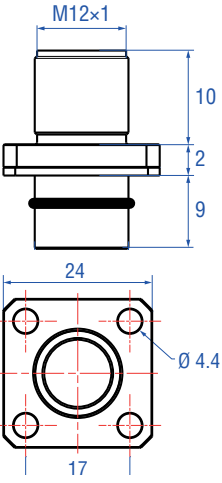

Fig. 30: Welding the cylinder with integrated sensor

NOTICE

- Cut or disconnect all sensor connections during welding.
- Never fasten the grounding point at the piston rod or at the cylinder pipe.
- Never perform welding work on a part of the cylinder, if a sensor has been installed.
- Never perform welding work near a cylinder, if a sensor has been installed.
- Due to isolating bearings, plastic slide bearings or grease in the contact points, electric potentials/voltages can build up at every bearing point of machines. Accordingly, similar effects as on hydraulic cylinders can be produced.

5.20 Frequently ordered accessories

Testkit	Adapter cables		M12 flange
			
<p>Test kit Analog Part no. 280 618</p>	<p>4 pin M12 to DTM06 connector Part no. 254 597</p>	<p>4 pin M12 to DT04 connector Part no. 254 600</p>	<p>M12 flange Part no. 253 769</p>
<p>Scope of delivery:</p> <ul style="list-style-type: none"> • Analog / PWM Tester • 12 VDC battery charger with adapter (adapter main plug EU, adapter main plug UK) • cables with M12 connector • cable with pigtailed wires • cable with Deutsch DT06-3S connector • carrying case • CD-Rom with user's guide 	<p>M12 connector: Brass/Nickel DT connector: DTM06 3 pin Material: PVC Jacket Cable length: 274 mm Cable Ø: 5 mm Operating temperature: -40...+105 °C</p>	<p>M12 connector: Brass/Nickel DT connector: DT04 3 pin Material: PVC Jacket Cable length: 274 mm Cable Ø: 5 mm Operating temperature: -40...+105 °C</p>	<p>Material flange: Brass nickel-plated Material O-ring: 13x1.6 NBR70</p>

Controlling design dimensions are in millimeters

6. Operation

6.1 Getting started

Electrical connections

Cable	
	
Color	A
BN	VDC
WH	GND
GN	SIG

Fig. 31: Wiring of cable output

M12 connector				
	Pin	E	G	H
	1	not connected	VDC	VDC
	2	VDC	not connected	SIG
	3	GND	GND	GND
	4	SIG	SIG	not connected

Fig. 32: Wiring of connector output

Cable shielding

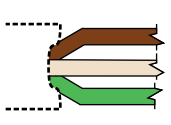
In the installed condition, the sensor is shielded sufficiently by the metal hydraulic cylinder. For this reason, no separate shielding is taken via the M12 connector. If a shielded cable is used, certain applications may require checking, if both ends of the shielding must be connected to the machine ground. When checking, the effect of any high voltage and high frequency field in the vicinity on the shield and on the signals in the cable should be taken into account.

M12 connector (4 pin) to DT04 connector (part no. 254 600)					
	Pin	DTM04	Pin	Function	
	1	B	A	VDC	
	2		-	-	
	3		B	GND	
	4	C	C	SIG	

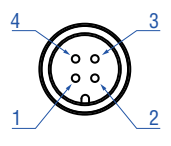
Fig. 33: Wiring of M12 connector to DT04 connector

M12 connector (4 pin) to DTM06 connector (part no. 254 597)					
	Pin	DTM06	Pin	Function	
	1		A	VDC	
	2		-	-	
	3		B	GND	
	4		C	SIG	

Fig. 34: Wiring of M12 connector to DTM06 connector

Machine ground

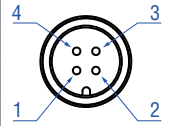
To ensure proper operation of the sensor, the hydraulic cylinder must be connected to the machine ground. Grounding is often ensured by the mechanical contact between the cylinder and other machine elements. If the cylinder is connected with the machine separately, separate grounding, for example via a grounding strap directly on the cylinder must be ensured.

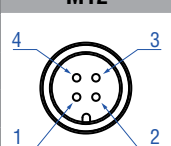
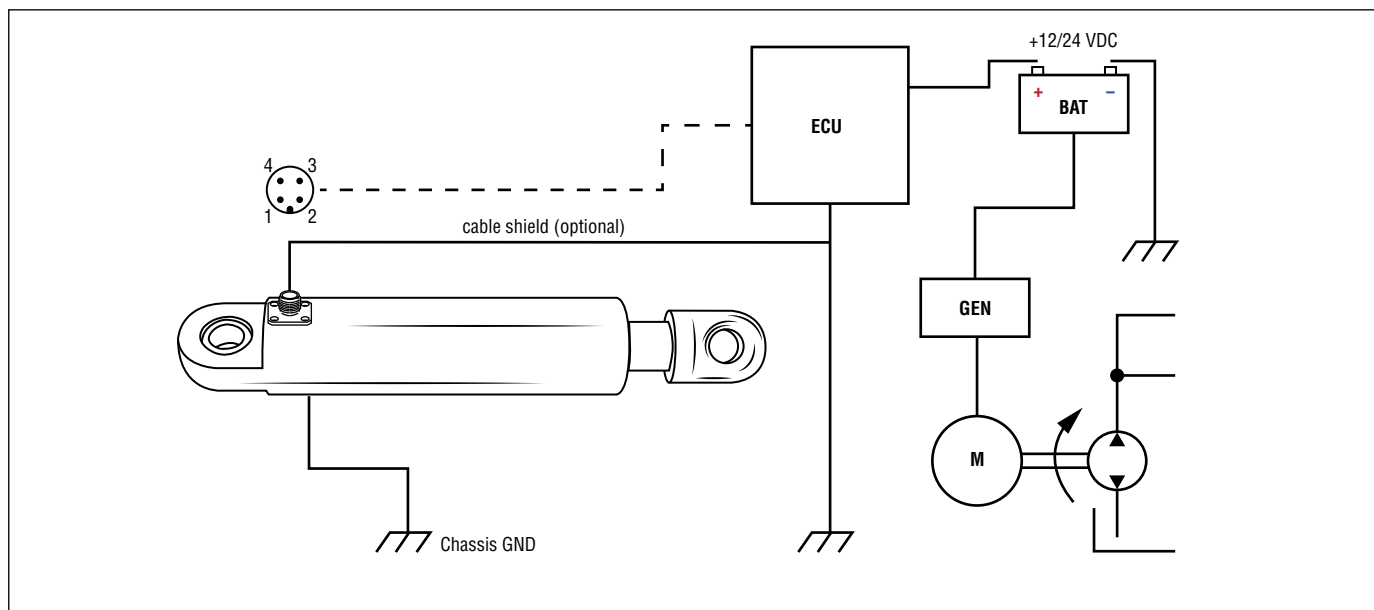

Fig. 35: Connecting schematics on vehicle electronics

Filter circuitry (noise)

Any resistor causes for example thermal noise, which is more or less evident at the output of the circuitry if amplified accordingly. Additionally, external effects such as the supply voltage ripple or electro-magnetic fields in the immediate vicinity can affect the noise spectrum. To minimize noise, the use of a filter is mandatory with analog measurement. A suitable solution for noise suppression is the following filter with a limiting frequency of approx. 3 kHz. (noise reduction factor 3.6). The signal delay is within the cycle time and changes the dynamic behavior only insignificantly.

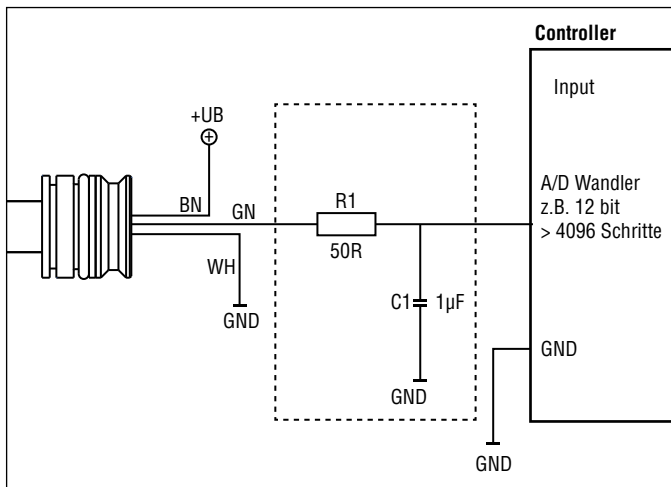

Fig. 36: Noise reduction

NOTICE
The resolution of the sensor output is influenced by the A/D converter of ECU input. For example:
8 bit = 256 steps
10 bit = 1024 steps
12 bit = 4096 steps

Signal output characteristic during power up time

The sensor is ready to run after the power up time. Within the power up time the output signal is "high": the indicated value is > F.S.O = Full Scale Output.

Output	F.S.O	Output „high“
mA (A01)	20 mA	22 mA
VDC (V12)	4.50 VDC	4.60 VDC

Fig. 37: High level

Set point tolerance zero to full scale

The Hall Effect sensor set points are calibrated with a tolerance of $\leq \pm 2$ mm. The tolerance field contains the magnetic tolerance of the position magnet, too. When installing in cylinders, please note that any additional tolerances must be taken into account. During teach-in, all tolerances in the cylinder-and-sensor system are eliminated. The piston rod drives towards the zero or full scale. The measured signals are programmed accordingly in the controller. During operation without teach-in, the following tolerances should be taken into account:

Example: Stroke length 400 mm

Voltage output:

- Signal: 0.5...4.5 V
- Signal span: 4000 mV
- Set point tolerance incl. magnet: ± 2 mm \triangleq 20 mV
- Set point tolerance: typical tolerance of start and full stroke
- Cylinder tolerance: ± 1 mm
- Electric signal with all tolerances:
Cylinder tolerance + set point tolerance = 3 mm
3 mm \triangleq 30 mV

Current output:

- Signal: 4...20 mA
- Signal span: 16 mA
- Set point tolerance incl. magnet: ± 2 mm \triangleq 0.08 mA
- Cylinder tolerance: ± 1 mm
- Electrical signal with all tolerances:
Cylinder tolerance + set point tolerance = 3 mm
3 mm \triangleq 0.12 mA

Set point tolerance VDC, e.g. 400 mm

Null position: $0.5 \text{ V} \pm 30 \text{ mV}$

For the null, the permissible tolerance is:

$0.5 \text{ V} \pm 30 \text{ mV}$.

Full scale: $4.5 \text{ V} \pm 30 \text{ mV}$

For the full scale, the permissible tolerance is:

$4.5 \text{ V} \pm 30 \text{ mV}$.

	Min	Max
Null	0.47 VDC	0.53 VDC
F.S.	4.47 VDC	4.53 VDC

Fig. 38: Set point tolerance of VDC output

Set point tolerance (mA output), e.g. 400 mm

Null position: $4 \text{ mA} \pm 0.12 \text{ mA}$

For the null, the permissible tolerance is:

$4 \text{ mA} \pm 0.12 \text{ mA}$.

Full scale: $20 \text{ mA} \pm 0.12 \text{ mA}$

For the full scale, the permissible tolerance is:

$20 \text{ mA} \pm 0.12 \text{ mA}$.

	Min	Max
Null	3.88 mA	4.12 mA
F.S.	19.88 mA	20.12 mA

Fig. 39: Set point tolerance of mA output

Typical values		
Cylinder stroke (mm)	250 mm	500 mm
Tolerances (mV)	50 mV	30 mV
Tolerances (mA)	0.20 mA	0.10 mA

Fig. 40: Typical values

After installing the sensor in the cylinder, the deviations from the required signal values are within the defined tolerances. These deviations must be taken into account by the control systems, or when determining limit values.

Insulation checks

Part of the testing performed on off-road mobile machinery can be insulation checks. During these checks, high voltages are applied to determine the dielectric strength of the cables against the housing (insulation resistance). For testing, all connecting cables must be disconnected from the sensors. Otherwise, stray voltage flowing through the sensor protective circuitry against ground can cause damage or failure of these components and of the sensors.

Mounting/dismounting cylinders on mobile hydraulics machines

As during transport, connectors, cables and cable ends should be protected sufficiently during mounting and dismounting. Cables and conductors must be neither subjected to load or tensile stress, nor bent. When connecting cables are installed, make sure that the insulation is not damaged by sharp edges.

Programming and configuration

No individual programming is provided for this type of sensor.

7. Maintenance and troubleshooting

7.1 Error conditions, troubleshooting

If the magnetic detection is lost, signal values rise to HIGH level (see chapter 6.1 on page 24).

7.2 Maintenance

The sensor is maintenance-free.

7.3 Repair

Repairs of the sensor may be performed only by MTS Sensors or a repair facility explicitly authorized by MTS Sensors.

7.4 List of spare parts

No spare parts are available for this sensor.

7.5 Transport and storage

Storage of sensors and magnet assemblies

The sensors are supplied with an O-ring made of NBR-rubber, the material aging of which is in the characteristic of the material and can not be avoided.

- Take appropriate storage precautions
- Protect the ferro magnetic magnet assy parts against rust

Storage of cylinders with integrated sensors

When transporting the cylinders, make sure that the cables and connectors are not under tensile stress. When handling/storing carelessly, connectors and cables can be squeezed easily between stacked cylinders.

Moreover, it is necessary to encapsulate the connections or exposed cable ends using an antistatic bag. For this, the original bags can be re-used. Furthermore, it is important to re-fit the white dust protective caps (part no. 403287) on the M12 connector system after installation of the connector. The cylinders storage conditions should be as dry as possible.

8. Removal from service / dismantling

The product contains electronic components and must be disposed of in accordance with the local regulations.

9. Technical data

Output	
Voltage	0.5...4.5 VDC
Current	4...20 mA
Measured value	Position
Measurement parameters	
Resolution	< 0.2 mm
Linearity	< ±1 mm typ.
Repeatability	< ±0.5 mm typ.
Hysteresis	< ±0.5 mm typ.
Operating conditions	
Operating temperature	-40...+85 °C
Humidity	95 % @ 55 °C (DIN EN 60068-2-30)
Ingress protection	M12 connector: IP69K plugged with mating connector EN60529; Sensor housing: IP67 EN60529
Shock test	50 g / 10 ms up to 500 mm sensor length (single shock) / IEC 60068-2-27 100 g / 6 ms up to 180 mm sensor length (single shock) / IEC 60068-2-27
Vibration test	Random Noise Peak Acceleration 15 g _{rms} based on DIN EN 60068-2-64 15 g / 20...2000 Hz Sinusoidal, IEC standard 60068-2-6 (resonance frequencies excluded)
EMC test	EN 61000-6-2 Radiated Immunity (industrial) EN 61000-6-4 Emissions (industrial) ISO 13766 Earth moving machinery DIN EN 13309 Construction machinery ISO 14982 Agricultural and forestry machinery The sensor meets the requirements of the EC directives and is marked with CE
Design / Material	
Sensor housing	Stainless steel 1.4301 (AISI 304)
Sensor rod	Stainless steel 1.4307 (AISI 304L)
Stroke length	100...500 mm
Operation pressure PN (nominal operating)	320 bar
Operation pressure Pmax	400 bar
Operation pressure Pstatic (proof pressure)	525 bar
Mechanical mounting	
Mounting position	Any
Mounting instruction	Please consult the technical drawings
Electrical connection	
Connection type	M12 male plug or cable assembly
Operating voltage	5 / 12 / 24 VDC (4.75...32 VDC) (400...500 mm 4.75...28 VDC)
Load (voltage output)	$R_L \geq 5 \text{ k}\Omega$
Load (current output)	$R_L \leq 50 \Omega$ (5 VDC), $R_L \leq 250 \Omega$ (12 VDC), $R_L \leq 500 \Omega$ (24 VDC)
Current consumption	$\leq 530 \text{ mA}$ (5 VDC), $\leq 200 \text{ mA}$ (12 VDC), $\leq 125 \text{ mA}$ (24 VDC)
Polarity protection (GND – VDC)	Up to 32 VDC
Overvoltage protection (GND – VDC)	Up to 50 VDC

10. Appendix

Safety Declaration

Dear Customer,

If you return one or several sensors for checking or repair, we need you to sign a safety declaration. The purpose of this declaration is to ensure that the returned items do not contain residues of harmful substances and / people handling these items will not be in danger.

RMA #: _____ Sensor type(s): _____

MTS Sensors order number: _____ Sensor length(s): _____

Serial number(s): _____

This sensor has been in contact with the following materials:

Do not specify chemical formulas.
Please include safety data sheets of the substances, if applicable.

In the event of suspected penetration of substances into the sensor, consult MTS Sensors to determine measures to be taken before shipment.

Short description of malfunction:

Corporate information

Company: _____

Address: _____

Contact person

Name: _____

Phone: _____

E-Mail: _____

We hereby certify that the measuring equipment has been cleaned and neutralized.
Equipment handling is safe. Personnel exposure to health risks during transport and repair is excluded.

Stamp

Signature

Date

USA
MTS Systems Corporation
Sensors Division
3001 Sheldon Drive
Cary, N.C. 27513, USA

Tel. +1 919 677-0100
Fax +1 919 677-0200
info.us@mtssensors.com
www.mtssensors.com

Germany
MTS Sensor Technologie
GmbH & Co. KG
Auf dem Schüffel 9
58513 Lüdenscheid
Germany

Tel. 02351/95 87-0
Fax. 02351/56 49 1
info.de@mtssensors.com
www.mtssensors.com



Temposonics

AN AMPHENOL COMPANY

UNITED STATES
Temposonics, LLC
Americas & APAC Region
3001 Sheldon Drive
Cary, N.C. 27513
Phone: +1 919 677-0100
E-mail: info.us@temposonics.com

GERMANY
Temposonics
GmbH & Co. KG
EMEA Region & India
Auf dem Schüffel 9
58513 Lüdenscheid
Phone: +49 2351 9587-0
E-mail: info.de@temposonics.com

ITALY
Branch Office
Phone: +39 030 988 3819
E-mail: info.it@temposonics.com

FRANCE
Branch Office
Phone: +33 6 14 060 728
E-mail: info.fr@temposonics.com

UK
Branch Office
Phone: +44 79 44 15 03 00
E-mail: info.uk@temposonics.com

SCANDINAVIA
Branch Office
Phone: +46 70 29 91 281
E-mail: info.sca@temposonics.com

CHINA
Branch Office
Phone: +86 21 2415 1000 / 2415 1001
E-mail: info.cn@temposonics.com

JAPAN
Branch Office
Phone: +81 3 6416 1063
E-mail: info.jp@temposonics.com

Document Part Number:
551904 Revision C (EN) 09/2018



temposonics.com

© 2021 Temposonics, LLC – all rights reserved. Temposonics, LLC and Temposonics GmbH & Co. KG are subsidiaries of Amphenol Corporation. Except for any third party marks for which attribution is provided herein, the company names and product names used in this document may be the registered trademarks or unregistered trademarks of Temposonics, LLC or Temposonics GmbH & Co. KG. Detailed trademark ownership information is available at www.temposonics.com/trademarkownership.